

# SHOULDER PUNCHES

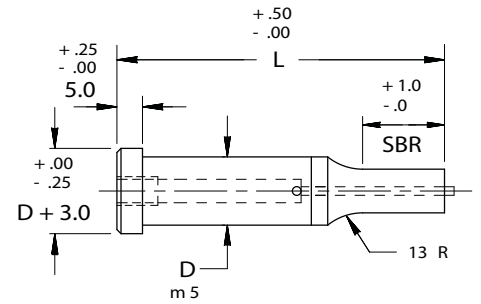

## EJECTOR

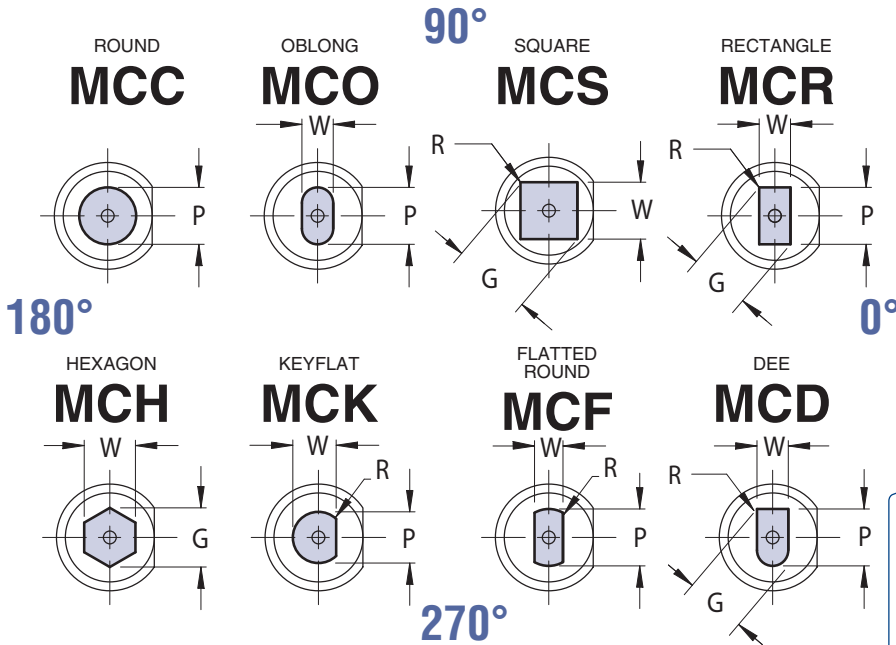

**ORDER EXAMPLE:**  
 (Reference page 4)  
 SPECIFY: QTY: TYPE "D" "L" POINT LENGTH (OR P&W) DIMENSIONS ALTERATION CODE ALTERNATE POINT TOLERANCE  
 EXAMPLE: 6 MCC 13 90 STD 10.0 F1 STD  
 EXAMPLE: 6 MCO 16 80 B 13.0 x 9.0 F1 T2  
 Note: When ordering, standard quantity breaks are: 1, 2-3, 4-11, 12-23, 24-49, 50-99

VIEWS ARE SHOWN LOOKING THROUGH THE SHANK BUT DRAWN WITH SOLID LINES FOR CLARITY.

Complete design & CAD files visit [WWW.MOELLERMCD.COM](http://WWW.MOELLERMCD.COM)

FOR STANDARD ALTERATIONS SEE PAGES 59-63.

CATALOG TYPE	SHANK DIA D	ROUND		SHAPE		OVERALL LENGTH "L"							
		RANGE P	MIN W	MAX G/P	50	56	60	63	70	71	80	90	100
MC_05	5	1.60 - 4.99	1.60	5.00	X	X	X	X	X	X	X	X	X
MC_06	6	2.50 - 5.99	2.50	6.00	X	X	X	X	X	X	X	X	X
MC_08	8	3.20 - 7.99	3.20	8.00	X	X	X	X	X	X	X	X	X
MC_10	10	4.50 - 9.99	4.50	10.00	X	X	X	X	X	X	X	X	X
MC_13	13	6.00 - 12.99	6.00	13.00	X	X	X	X	X	X	X	X	X
MC_16	16	8.00 - 15.99	7.50	16.00	X	X	X	X	X	X	X	X	X
MC_20	20	10.00 - 19.99	8.00	20.00		X	X	X	X	X	X	X	X
MC_25	25	12.00 - 24.99	9.00	25.00		X	X	X	X	X	X	X	X
MC_32	32	16.00 - 31.99	10.00	32.00				X	X	X	X	X	X
MC_40	40	30.00 - 39.99	14.00	40.00							X	X	X

NOTE: FOR EXTENDED RANGE SHANK DIAMETERS OF 45, 50, 56 & 63, SEE PAGE NO. 20, 21

**Material**  
 Steel: M2, HRC 60-63  
 Heads HRC 45-55

**Standard Point Tolerance**

Round P  $\begin{matrix} +.01 \\ -.00 \end{matrix}$  .01 P to D

Shape P, W  $\pm .01$  .02 P to D

**Alternate Point Tolerance** **T2**

P, W TOLERANCE  $\begin{matrix} +.005 \\ -.000 \end{matrix}$

P to D  $\begin{matrix} .008 \\ \end{matrix}$

CATALOG TYPE	SHANK D	SBR			EJECTOR SIZE
		NAPMA STD	ALTERNATES B C		
MC_05	5	13	10	—	MAE 2
MC_06	6	13	10	—	MAE 3
MC_08	8	19	13	—	MAE 4
MC_10	10	19	13	25	MAE 5
MC_13	13	19	13	25	MAE 5
MC_16	16	19	13	25	MAE 6
MC_20	20	19	13	25	MAE 6
MC_25	25	19	13	25	MAE 6
MC_32	32	25	19	30	MAE 6
MC_40	40	25	19	30	MAE 6

STANDARD FLAT LOCATION IS AT 0° AS SHOWN.  
 AVAILABLE AT 90°, 180°, 270°, FOR SAME ALTERATION PRICE.

L=50 SBR MAX=13 L=60 SBR MAX=19  
 L=56 SBR MAX=19 L=63 SBR MAX=25