

122



MODEL NO	F1 (N)	F2 (N)	F3 (N)	F4 (N)	Fi		AÇI (ANGLE) (± 5°)	AĞIRLIK (WEIGHT) (gr)
					X1 VERİM (YIELD) (F1:Fi)	X2 VERİM (YIELD) (F2:Fi)		
122 - 3	2500	1250	2800	1400	9:1	4,5:1	71°	490

F1 - F2 : BASKI KUVVETİ ( EXERTING FORCE ) , F3 - F4 : TUTMA KAPASİTESİ ( HOLDING CAPACITY ) , Fi : UYGULAMA KUVVETİ ( APPLIED FORCE )



**Ayak Tipi: Yatay, Yüksek Tabanlı**  
Body Mounting Base: Horizontal, High Base

**Ürün özellikleri ;**

Yüksekliği otomatik ve kademesiz olarak ayarlanabilen çene sayesinde 55 mm kalınlığa kadar olan iş parçalarını baskı kuvveti değişmeden sıkıştırabilir. Sıkma kuvveti mekanizma üzerinde bulunan ayar vidasından ayarlanabilir.

**Product features:**

The automatic and continuously adjustable clamp arm enables clamping of work pieces of up to 55 mm without any variation in the exerted force. The clamping force can be adjusted to your particular needs by turning the setscrew on the mechanism.

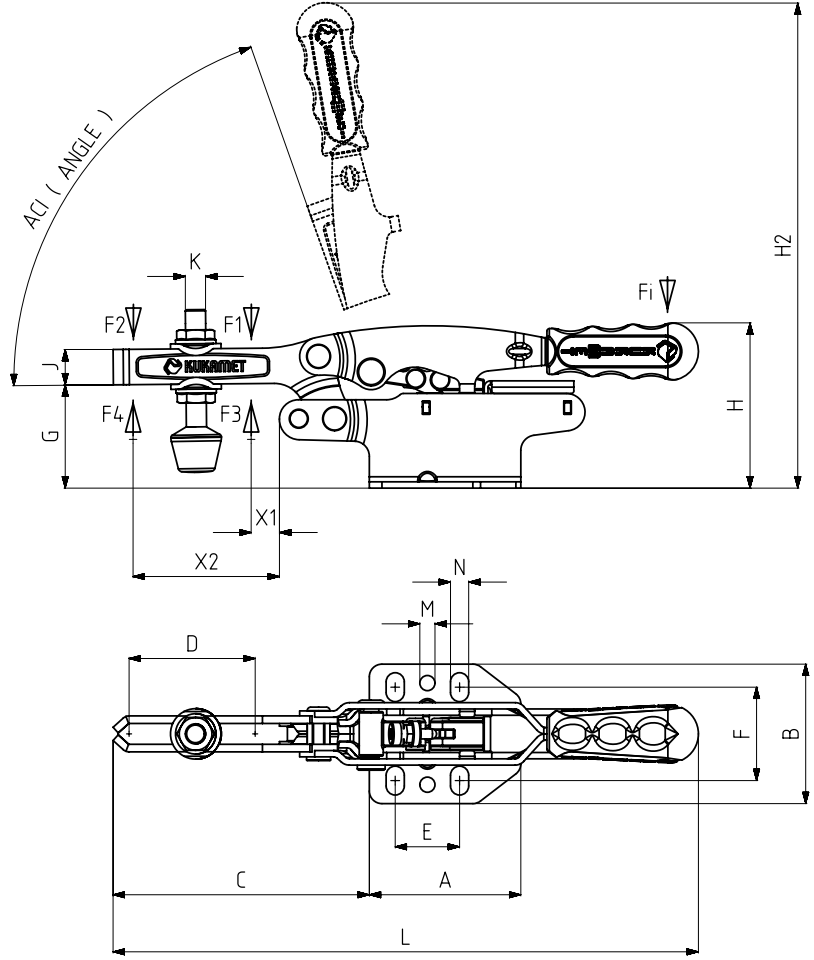

MODEL NO	A	B	C	D	E~	F~	G	H	H2	J	K	L	M	N	X1	X2
122 - 3	60	55,5	101,5	50	25,5	32,5 - 41	41	65,5	201,5	14	M8	232	Ø6	7x11,5	16	50