

621



MODEL NO	F1 (N)	F3 (N)	Fi (N)	Vn (dm ³)	STROK	AĞIRLIK (WEIGHT) (gr)	BAR
621 - 3 (Ø 12)	1500	2960	300	0.25	23	1140	6
621 - 3 (Ø 14)	2500	3200	500	0.51	23	1310	6
621 - 4 (Ø 16)	4500	6650	750	1.04	33	2230	6
621 - 4 (Ø 18)	4500	7200	750	1.04	33	2260	6
621 - 5 (Ø 20)	7500	15000	1100	2	42	3860	6

F1 : BASKI KUVVETİ (EXERTING FORCE) , F3 : TUTMA KAPASİTESİ (HOLDING CAPACITY) , Fi : UYGULAMA KUVVETİ (APPLIED FORCE)

Vn, 6 BAR BASINÇTA ÇİFT HAREKET İÇİN HAVA TÜKETİM MİKTARIDIR (Vn, AIR CONSUMPTION PER DOUBLE STROKE IN dm³ AT 6 BAR)

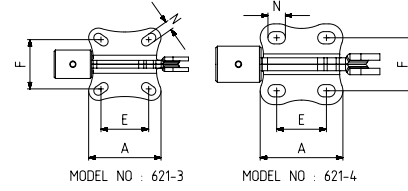
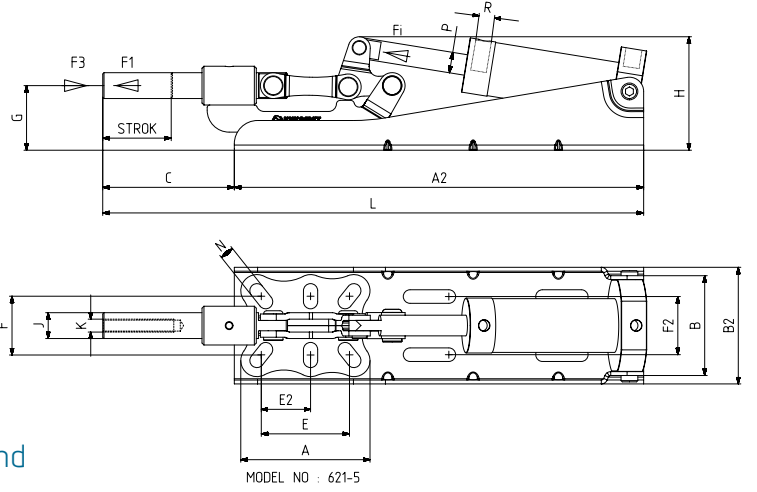

Ayak Tipi: Yatay Tabanlı, Kaynaklı, Arka Bağlantılı
Body Mounting Base: Horizontal With Welding, Tied Behind



661

Sayfa/Page: 74

521

Sayfa/Page: 53

641

Sayfa/Page: 70

Pistonlar çift etkili, manyetik ve yastıklıdır.
Pneumatic cylinders are double acting, magnetic and cushioning



MODEL NO	A	A2	B	B2	C	E ~	E2 ~	F ~	F2 ~	G	H	J	K	L	N	P	R	PİSTON Ø
621 - 3 (Ø 12)	56	226	51	68	70	32,5 - 41		35 - 41	35	35	65	12	M8	296	7 x 12	Ø 10	G1/8	25
621 - 3 (Ø 14)	56	243	58	68	70	32,5 - 41		35 - 41	35	35	71,5	14	M8	314	7 x 12	Ø 12	G1/8	32
621 - 4 (Ø 16)	64	289	77	78	84	34,5 - 42,5		41	41	43	89	16	M10	375	9,5x13,5	Ø 16	G1/8	40
621 - 4 (Ø 18)	64	289	77	78	84	34,5 - 42,5		41	41	43	89	18	M10	375	9,5x13,5	Ø 16	G1/8	40
621 - 5 (Ø 20)	100	355	79	92	101	61,5 - 75	34,5 - 41,5	37 - 54	45	51	105	20	M12	460	11 x 22	Ø 20	G1/8	50