

MOELLER™

PRECISION TOOL

YOUR GLOBAL PARTNER FOR STANDARD & SPECIAL DIE COMPONENTS

PUNCHES • DIE BUTTONS
AND RETAINERS



VALUE • QUALITY & SERVICE
TECHNOLOGY



MOELLER™ PRECISION TOOL

Your Global Partner for Standard and Special Tooling Components

Our commitment to continuous improvement is reflected in true innovation in our management, processes, equipment and facilities. We take pride in our reputation of excellent service, quality performance, value and the understanding that our own interests are best served when we best service our customers.



HEADQUARTERS, WIXOM, MICHIGAN, U.S.A.



TENNESSEE



MEXICO



CANADA



ITALY



UNITED KINGDOM

CONVENIENCE - Fast, courteous, personalized attention to accommodate your special or emergency requirements.

CONFIDENCE - Performance guaranteed products, SPC controlled and ISO audited to exceed the Industry's highest standards.

VALUE - The latest technology and innovative processes provide the world's highest performance tools priced to help your bottom line.



MOELLER PRECISION TOOL

STANDARD INCH AND METRIC PRODUCTS



PERFORMANCE ENHANCEMENT TOOLS AND COATINGS



PDF VERSIONS OF ALL MPT CATALOGS ARE AVAILABLE ONLINE
www.moellerprecisiontool.com





VALUE • QUALITY & SERVICE • TECHNOLOGY

ADVANCED STAMPING APPLICATION TOOLING

Moeller Precision Tool's core values of continuous product innovation, providing tailored solutions to our customers, and using advanced manufacturing capabilities to provide the highest quality products are the pillars of our brand. As the industry moves toward more complex applications and more demanding materials, MPT has expanded our standard catalog offerings to support our customers with this "Advanced Application Tooling" catalog expansion. Our catalogs provide standard M2 and A2 material, along with PM-M4 and M2 steel to improve tool life and reduce down time in the most extreme conditions.

STANDARD PIERCE PUNCH MATERIAL:

PM-M4 – Advanced Applications, M2 – Standard Applications

STANDARD DIE BUTTON MATERIAL:

M2 – Advanced Applications, A2 – Standard Applications

KEY COMPONENTS AVAILABLE IN THIS CATALOG FOR ADVANCED APPLICATIONS:



Dura Punch: Designed with thicker, larger, and 10-degree angled diameter heads to reduce failure when piercing heavy gauge and high strength materials.

Dura Punch Retainer: Standard, off the shelf retainer specifically for Dura Punches.



Exclusive Trumpet Head Punch: Designed with advanced head geometry to withstand the most extreme piercing applications.

Exclusive Trumpet Head Retainer: Standard, off the shelf retainer specifically for Trumpet Head punches.

Available in METRIC ONLY - see Metric Catalog



Exclusive True Set Advanced Ball Lock Retainer: The industry's only one-piece construction retainer manufactured from shock-resistant steel, created for the most demanding applications such as AHSS and aluminum.

Exclusive True-Fit Ball Lock Insert: A one-piece construction ball lock insertable retainer.



Exclusive Snap-in Urethane Retainer: An economical urethane retaining device, adaptable to all standard and special multi-hole retainers manufactured by MPT.



Exclusive True Strip: MPT's exclusive high-performance mechanical stripper. See MPT's True Strip catalog for more information and part specifications.



Performance Enhancement Coatings: MPT provides recommendations for advanced surface treatments to achieve maximum tool life.

For additional MPT product catalogs and services, visit www.moellerprecisiontool.com



EXCEEDING INDUSTRY STANDARDS FOR OVER 60 YEARS

EXCLUSIVE PRODUCT LINE AND CAPABILITIES



TRUE SET ADVANCED BALL LOCK RETAINER

The industry required a next-generation retainer, so MPT designed a one-piece construction retainer which eliminates old plug and backing plate style methods. Our retainers are produced from through-hardened, shock resistant material and machined to exacting tolerances.



TRUE-FIT INSERTABLE BALL LOCK RETAINERS

Our newest innovation! The most economical installation for ball lock retainers, manufactured as a one-piece constructed component.



TRUE SET TRUMPET STYLE AND DURA PUNCH RETAINERS

MPT now offers a standard, off-the-shelf retainer for Trumpet Head punch and Dura Punch head geometry, manufactured to True Set quality standards.



TRUE SET SNAP-IN URETHANE STRIPPER RETAINERS

MTR: Our exclusive, one-piece construction for simplified installation is designed to extend urethane life and provide precision perpendicularity.

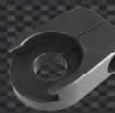

MTM: This innovative design will adapt to all standard and special multi-hole retainers without the required tapped fastening hole.



TRUE STRIP MECHANICAL STRIPPERS

The world's highest performing mechanical stripper for exceeding the life of urethane with the supporting function to withstand side load and prevent point breakage.



TRUE LOCK BALL LOCK RETAINERS

The revolutionary ball lock system re-engineered for perfect alignment and positive locking position between punches and retainers, guaranteed!

ADVANCED MACHINING CAPABILITIES

3D Surfacing, Key Hole, Spline and Universal Shaped Tools, Extrusion, Countersink Coining, Compacting and other Metal Forming Tools

MOELLERTM
PRECISION TOOL

MPT CRIB.COM

INVENTORY MANAGEMENT SYSTEM



SYSTEM BENEFITS:

- INDUSTRY EXCLUSIVE SOFTWARE
- EASY AUDIT & ADAPTATION
- AUTOMATED MANAGEMENT
- REMOTE ACCESS & MORE!

ORGANIZED EFFICIENCIES

www.moellerpunch.com/mptcrib-tool-management-system





INTRODUCING A REVOLUTIONARY WEB-BASED DIE DESIGN SOLUTION

*Moeller Precision Tool's Web-Based Tool Design Application Features
Exclusive Fail-Safe and Geometrically Accurate Modeling*

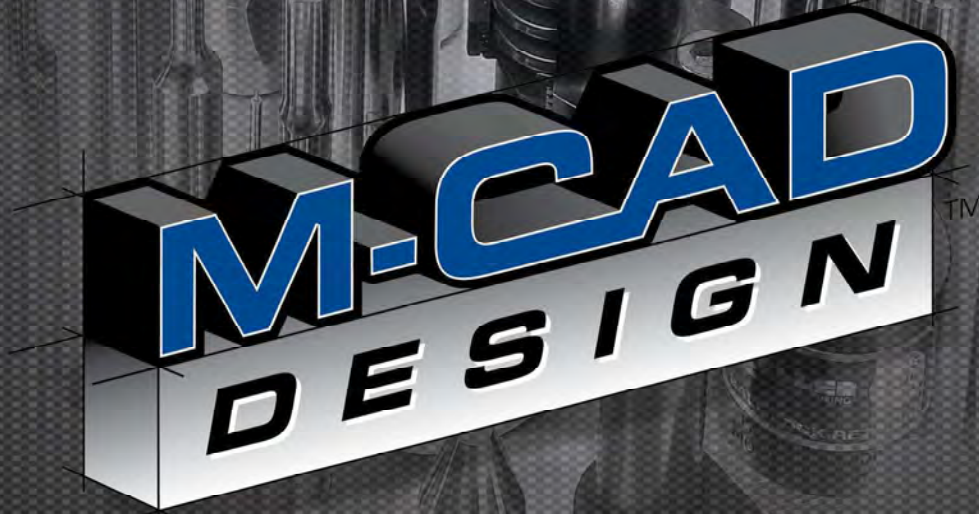

**Intelligence-based M-CAD Provides Real-Time Feedback,
Preventing Inaccurate Models and is Never Obsolete**

**User Configured Solid Models Available for Download
CATIA V4, V5 and Other Universal File Formats**

Full Project Management and Data Sharing

Generate Bill of Materials, Quotes and Order Requests

Standard Pierce Tooling, Mechanical Die Springs & Nitrogen Gas Springs

moellerpunch.com/m-cad-info



Powered by



**CADENAS
PARTsolutions**

Policies, Terms & Conditions	2
Delivery Schedule	3
Catalog Nomenclature & Ordering Example	4,5

BALL LOCK PUNCHES HEAVY DUTY

MH_ Solid with Standard Point	6
ME_ Ejector with Standard Point	7
MH_ Pilots	8,9
M_B Blanks	10
MN_ Nose Large Solid with Standard Point	11
MW_ Nose Large Ejector with Standard Point	12

BALL LOCK PUNCHES LIGHT DUTY

ML_ Solid with Standard Point	13
MJ_ Ejector with Standard Point	14
ML_ Pilots	15
M_B Blanks	16
MO_ Nose Large Solid with Standard Point	17
MV_ Nose Large Ejector with Standard Point	18

SHOULDER PUNCHES BASIC

MS_ Solid with Standard Point	19
MC_ Ejector with Standard Point	20
MS_ Solid/Extended Range	21
MC_ Ejector/Extended Range	22
MS_ Pilots	23,24
MSW Pilots/Compact Pointed Type	25
MSV Pilots/Compact Straight Type	26
M_B Blanks	27

SHOULDER PUNCHES WITH CENTER DOWEL

MS_ Solid with Center Dowel	28
MC_ Ejector with Center Dowel	29
MSA Pilots with Center Dowel	30

REDUCED SHANK PUNCHES

MSX Solid	31
MCX Ejector	31

QUILL PUNCHES

MQS Square Head	32
MQB Bevel Head	32

DURA PUNCHES®

XMS_ Solid with Standard Point	33
XMC_ Ejector with Standard Point	34
XM_B Blanks	35

TRUMPET HEAD PUNCHES

XMT_ Solid with Standard Point	36
XMTB Blanks	37

PRESS FIT BUTTONS

MD_ Counter Bore Relief with Standard Hole	38
MD_ Counter Bore Relief/Extended Range	39
MU_ Ultra Life/Taper Relief with Standard Hole	40
MU_ Ultra Life/Taper Relief/Extended Range	41
MK_ Counter Bore Relief/Slip Fit	42

SHOULDER BUTTONS

MI_ Counter Bore Relief with Standard Hole	43
MM_ Ultra Life/Taper Relief with Standard Hole	44

BALL LOCK BUTTONS

MB_ Counter Bore Relief with Standard Hole	45
--	----

BUTTON BLANKS

M_B Blanks with Counter Bore Relief	46
M_B Blanks with Straight Thru Hole	47
MBB Ball Lock with Counter Bore	48
MFB Ball Lock with Straight Thru Hole	48

UNIVERSAL SHAPES

M_U	49, 50, 51
-----------	------------

RETAINERS

MRH Advanced True Set	52
MR_ Ball-Lock True Set - Standard	53
MRR Ball-Lock Economy Round True Set	54
MRM Mini True Set Ball Lock	55
MR_ True Fit Heavy Duty Ball Lock	56
MRK Economy Ball Lock Insert	57
MR_ Shoulder True Set	58, 59
XMRN Round Dura Punch Retainers	60
XMRO Shaped Dura Punch Retainers	60
XMRT Retainer & Accessories	61
MR_ Retractable Retainers/Ball Lock	62
MR_ Retractable Retainers/Shoulder	63
Multi Hole Ball-Lock	64

RETAINER ACCESSORIES / COMPONENTS

TL True-Lock	65
Retainer Components	66
Retainer Accessories	67
MAX True Set Retainer Shims	67
MAY Economy Round True Set Retainer Shims	67

URETHANE STRIPPERS AND ACCESSORIES

MTC Strippers Closed End	68
MTS Strippers True Set (NAAMS)	69
MTR Standard True Set Stripper Retainer	70
MTP Economy True Set Stripper Retainer	70
MTM Mini True Set Stripper Retainer	70
MTB Nose Large Punch Strippers	71

SPECIAL TOOLING

Relocation Bushings	72
---------------------------	----

EJECTOR COMPONENTS

PRODUCT ALTERATIONS

Locating Devices	74,75
Out of Range "P" "W" or "B"	76,77
Button Slug Control	77
Additional Alterations	77
Overall Length or Head Alterations	78
Cross Pin, Extrusions, Shank Reduction	79
Shear Angles	80

TECHNICAL TOPICS

Clearances Chart	81
Surface Treatment Chart	81
Surface Treatment Descriptions	82,83

POLICIES, TERMS AND CONDITIONS



Moeller's "Purchase With Confidence" Guarantee!

- Customer satisfaction is Moeller's ultimate goal.
- Moeller was the first domestic punch manufacturer to receive its ISO certification. Moeller products are manufactured to NAPMA, NAAMS or other recognized industrial standards and are 100% interchangeable with all competing brands.
- Moeller uses only the highest commercially available grades of high speed and tool steels. The products are heat treated to exacting specifications then processed on some of the best equipment in the industry.
- Moeller products are warranted to meet or exceed the performance of like products from competing brands. If a customer is unsatisfied, Moeller will replace or allow the customer to return the product for full credit.

Over Shipments/Under Shipments for Per Print Special Items:

Because of normal part loss due to machine set-up on special items, Moeller requires that an over or undershipment of $\pm 10\%$ be allowed on quantities of 13 pieces or more.

Partial Shipments:

Standard line items are batched together and shipped on the latest ship date by quoted lead time. Specials are shipped according to line item ship dates.

Note: Moeller will accommodate any partial shipment as requested by the customer.

Returns:

1. Catalog items that are custom ground to customer specifications are often non reusable; Moeller will apply discretion for a 15% credit for reusable items.
2. Unused, off the shelf items such as punch blanks and standard retainers can be returned for a 15% restocking charge. The item must be in the original packaging in resalable condition.
3. Special "make-to-print" items are not returnable.
4. Moeller reserves the discretion for all returns exceeding one year from invoice date.

Method of Shipment:

Moeller ships UPS or Federal Express whenever possible, unless weight requirements dictate truck delivery, or as specifically requested by the customer.

Cancellation:

If labor or material has been applied to a cancelled job, a prorated charge will be billed.

Prices/Standards:

See current price supplement in effect.

Prices/Specials:

Per factory quotation good for 90 days or as specified.

Terms:

Net 30 days, F.O.B. our plant. U.S. dollars.

Moeller "Customer Service Stock" Program:

Moeller is pleased to offer an exclusive Service Stock Program to select customers. The "Customer Service Stock" program offers many benefits to our valued customers, including product cost reduction, immediate "on hand" availability, and reduced customer inventory costs. Moeller will manufacture your annual or semi-annual requirements for Pierce Tooling and Die Components and make them available for immediate shipment. The parts are billed only as shipped. A written purchase order is required with inventory set-up and parts must be released in the subsequent year. Please contact your Moeller Sales Representative for more details.

- Moeller reserves the right to modify, correct or improve this literature or products without notice.

DELIVERY SCHEDULE/ EXPEDITED SERVICES



STANDARD DELIVERY

SAME DAY / 1 DAY:

- Punch and Button Blanks, Standard Retainers and All Other Stocked Products. **With No Alterations.**

3 WORKING DAYS:

- Standard In-Range Punches and Die Buttons Includes one Standard Alteration
- Quantities of 23 Pieces or Less

5 WORKING DAYS:

- Nose Large Punches & Ultra Life Extended Range Buttons. Includes one Standard Alteration
- Quantities of 7 Pieces or Less

10 WORKING DAYS:

- Counter Bore Relief Extended Range Buttons
- Slip Fit Counterbore Relief Buttons Over 40mm Diameter
- Universal Shaped Punches and Die Buttons. Closed End Strippers

PERFORMANCE ENHANCER:

- TIN, TCN, TAN, ACD, ACA, MWU, MAY, MSP CRN, ACO, ACE, MTN, ESF

NOTE: 2-10 Additional Work Days to the Standard Delivery Date

ORDERS MUST BE RECEIVED BEFORE 11:00AM EST (OR AS APPROVED BY A CUSTOMER SERVICE REPRESENTATIVE) TO BE CONSIDERED A WORK DAY.

QUANTITIES LARGER THAN 23 PIECES MAY REQUIRE ADDITIONAL LEAD TIME. CUSTOMER SERVICE REPRESENTATIVE MUST CONSULT FACTORY.

E.D.S. EXPEDITED DELIVERY SERVICE Products Shipped Earlier Than Standard Delivery

LEAD TIME:

- As Negotiated with a Customer Service Representative

QUALIFYING PRODUCTS:

- All Standard Catalog Items

COST:

- List Price + 25% Net
- Minimum Order = \$25.00

N.D.S. NEXT DAY SERVICE Standard Products Received by 5:30 p.m. EST Will Ship Next Day

QUALIFYING PRODUCTS:

- Round Piercing Products (excluding Ultra Life)

REQUIRED SPECIFICATIONS:

1. N.D.S. Items MUST be on an Independent Order (i.e. they must be separate from other delivery items)
2. Service Limited to Quantities of 1-20 Pieces
3. MUST be within Standard Catalog Range
4. Customer MUST Specify Next Day Service
5. Customer SHOULD Specify Method of Shipment (e.g. UPS, UPS Next Day Air, Pick Up, etc.)

COST:

- No Additional Charge

REQUIRED SPECIFICATIONS MUST BE CLEARLY STATED ON INDEPENDENT PURCHASE ORDER(S) TO GUARANTEE NEXT DAY SERVICE.

S.D.S. SAME DAY SERVICE

LEAD TIME:

- Orders MUST be received before 11:00 a.m. EST or as approved by a Customer Service Representative

QUALIFYING PRODUCTS:

1. Catalog Standard Products with Only One Standard Alteration
2. Round Products - 20 Piece Maximum
Shaped Products - 10 Piece Maximum
3. Coating Excluded
4. Excluded Products:
 - Nose Large Punches, Large Buttons, Urethane, Close Space or Quill Punches
 - Some Descriptive Shaped Products

COST:

- List Price + 50% Net
- Minimum Order = \$50.00

CUSTOMER SERVICE REPRESENTATIVE MUST RECEIVE APPROVAL FROM EITHER PRODUCTION CONTROL MANAGER OR PLANT SUPERINTENDENT.

CATALOG NOMENCLATURE

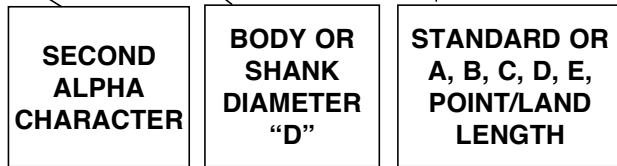
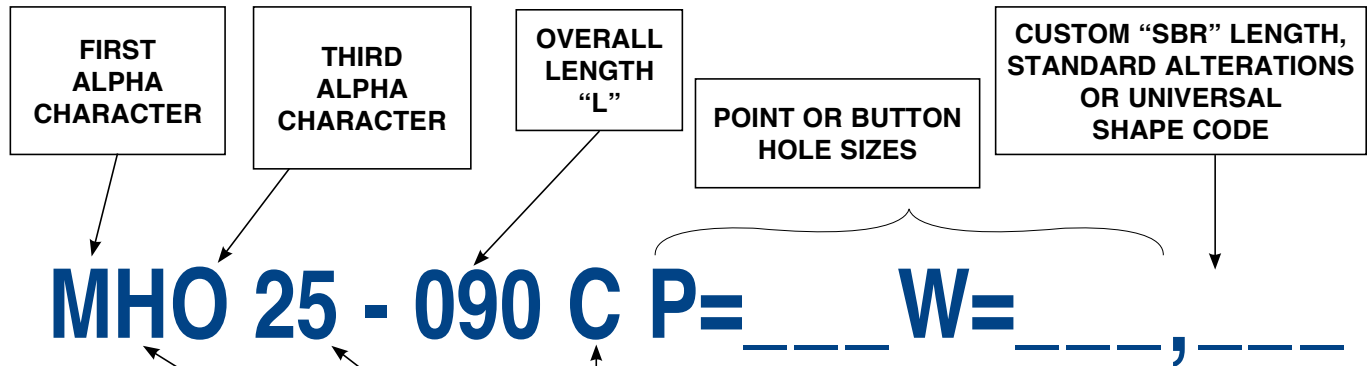

FIRST CHARACTER MEASUREMENT SYSTEM
M = Metric Products

- SECOND CHARACTER**
- Product Type**
- A Accessories
 - B Ball Lock Buttons Counter Bore Relief
 - C Shoulder Punch Ejector
 - D Press Fit Button Counter Bore Relief
 - E Ball Lock Punch Heavy Duty/Ejector
 - F Ball Lock Button Ultra Life/Taper Relief
 - H Ball Lock Punch Heavy Duty/Solid
 - I Shoulder Button Counter Bore Relief
 - J Ball Lock Punch Light Duty/Ejector
 - K Slip Fit Button/Counter Bore
 - L Ball Lock Punch Light Duty/Solid
 - M Shoulder Button Press Fit Ultra Life/Taper Relief
 - N Nose Large Punch Heavy Duty/Solid
 - O Nose Large Punch Light Duty/Solid
 - Q Quill Punch Square/Bevel Head
 - R Retainers
 - S Shoulder Punch Solid
 - T Strippers
 - U Press Fit Button Ultra Life/Taper Relief
 - V Nose Large Punch Light Duty/Ejector
 - W Nose Large Punch Heavy Duty/Ejector

- THIRD CHARACTER**
- | | |
|---|--|
| <p>Punches or Buttons</p> <ul style="list-style-type: none"> A Pilot - Long Lead B Blank - Punch & Button C Circular D Dee F Flatted Round H Hexagon K Key Flat O Oblong P Pilot Bullet Nose Q Thread Form R Rectangle S Square T Pilot Standard U Universal Shapes V Straight Compact Long Lead Pilot W Pointed Compact Long Lead Pilot X Reduced Body <p>Punch Retainers</p> <p>Ball Lock</p> <ul style="list-style-type: none"> A Retractable B/L H True Set Heavy Duty L True Set Light Duty M Mini True Set R True Set Economy Round Heavy Duty <p>Insertable True-Fit</p> <ul style="list-style-type: none"> I True Set Style J Backing Plate Style K Economy Ball Lock Insert <p>Shoulder</p> <ul style="list-style-type: none"> B Retractable Shoulder Shaped C Retractable Shoulder Round N Shoulder Style - Round O Shoulder Style - Shaped P Shoulder Retainer - 3 Dowel - Round Q Shoulder Retainer - 3 Dowel - Shaped <p>Strippers</p> <p>True Strip Units for Ball Lock Retainers</p> <ul style="list-style-type: none"> J True Strip Unit - Economy Round Ball Lock L True Strip Unit - Economy Blank Ball Lock T True Strip Unit - Round Ball Lock U True Strip Unit - Blank Ball Lock Z True Strip Unit - Shape Ball Lock | <p>True Strip Units for Shoulder Retainers</p> <ul style="list-style-type: none"> V True Strip Unit - Blank Shoulder W True Strip Unit - Shape Shoulder X True Strip Unit - Round Shoulder <p>Urethane Strippers</p> <ul style="list-style-type: none"> C Closed End Strippers O Open End Strippers S Strippers - True Set <p>Urethane Stripper Retainers</p> <ul style="list-style-type: none"> B Nose Large M Mini True Set Stripper Retainer (Snap in) N Naams Stripper Retainer (2 Piece) P Economy (Snap in) R True Set Stripper Retainer (Snap in) <p>Accessories</p> <ul style="list-style-type: none"> A True Strip Assembly Tool B Balls C Cap Screws, Ball Release Screws D Dowels E Ejector Component Assembly K Button Retention Key L Ejector Pin Lockout Kit M Mini True Set Retainer Shim Plates N Retainer Angle Hole Set Screw O Retainer Angle Hole Hex Wrench P Pins Ejectors R Relocation Bushings S Springs T Ball Release Tools W Shoulder Retainer Backing Plate X True Set Retainer Shim Plates Y Round Retainer Shim Plates |
|---|--|

ORDER EXAMPLE: Ball lock punch heavy duty with oblong point and SBR Length of 25, standard alteration of ballseat rotated to 45° degrees

MHO 025-090 C P=22.0 W= 15.3, BS@45° PM4
MUST SPECIFY PM4

Note: When ordering, standard quantity breaks are: 1, 2-3, 4-11, 12-23, 24-49, 50-99

EXTENDED PRODUCT LINE

CATALOG NOMENCLATURE

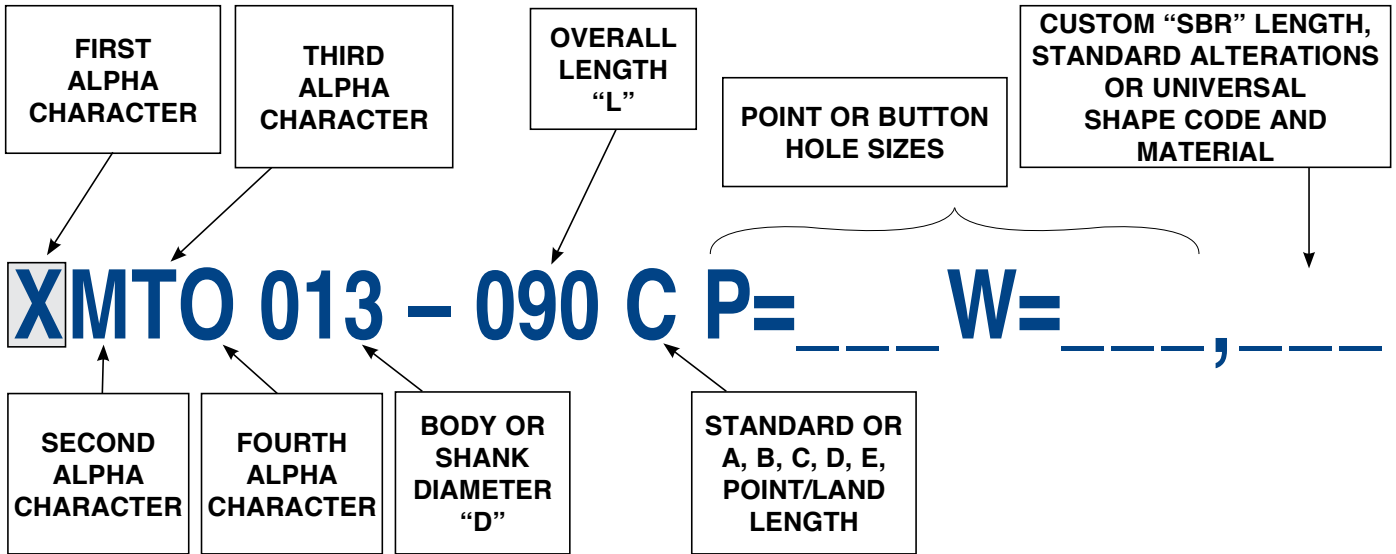

FIRST CHARACTER	SECOND CHARACTER	THIRD CHARACTER	FOURTH CHARACTER
X = Extended Product Line	MEASUREMENT SYSTEM M = Metric Products	Basic Body Type A Accessories C Dura Punch Standard - Ejector R Retainers S Dura Punch Standard - Solid T Trumpet Head Punch - Solid	Punches or Buttons B Blank C Circular D Dee F Flattened Round H Hexagon K Key Flat O Oblong R Rectangle S Square U Universal Shapes Shoulder Retainers N Dura Head - Round O Dura Head - Shaped T Trumpet Head - Round Accessories K Endmill for Trumpet Head Retainers Q Trumpet Head - Punch Retention Sleeve

ORDER EXAMPLE: Trumpet head punch with oblong point and SBR length of 25, standard flat alteration rotated to 90° degrees.

XMTO 013-090 C P=8.00 W=6.25, F1@90 PM4
MUST SPECIFY PM4

Note: When ordering, standard quantity breaks are:
 1, 2-3, 4-11, 12-23, 24-49, 50-99

BALL LOCK PUNCHES

HEAVY DUTY/SOLID

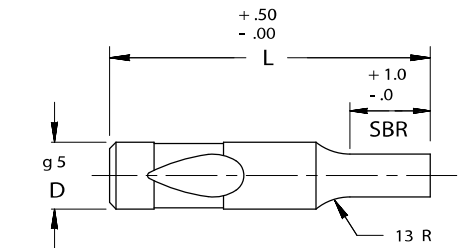
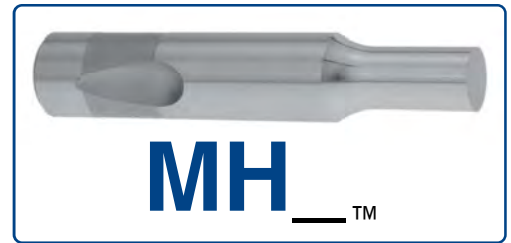
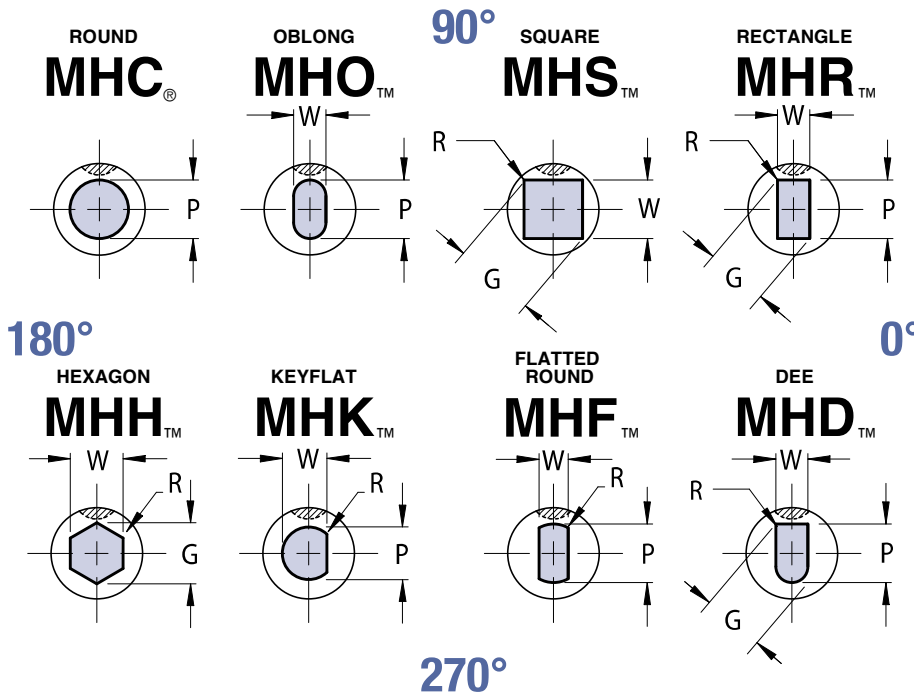

ORDER EXAMPLE:

(Reference page 4)

SPECIFY:	QTY:	TYPE	"D"	"L"	POINT LENGTH	P(OR P&W) DIMENSIONS	MATERIAL
EXAMPLE:	6	MHC	13	90	C	8.0	M2
EXAMPLE:	6	MHO	16	80	STD	14.0 x 7.0	PM4

Note: When ordering, standard quantity breaks are: 1, 2-3, 4-11, 12-23, 24-49, 50-99

VIEWS ARE SHOWN LOOKING THROUGH THE SHANK BUT DRAWN WITH SOLID LINES FOR CLARITY.

Complete design & CAD files visit WWW.MOELLERMCD.COM

FOR PRODUCT ALTERATIONS SEE PAGES 74-80.

CATALOG TYPE	SHANK DIA D	ROUND	SHAPE		OVERALL LENGTH "L"					
		RANGE P	MIN W	MAX G/P	71	80	90	100	110	125
MH_10	10	2.50 - 9.98	2.50	10.00	X	X	X	X	X	X
MH_13	13	5.00 - 12.98	4.50	13.00	X	X	X	X	X	X
MH_16	16	8.00 - 15.98	6.00	16.00	X	X	X	X	X	X
MH_20	20	12.00 - 19.98	8.00	20.00	X	X	X	X	X	X
MH_25	25	16.00 - 24.98	10.00	25.00		X	X	X	X	X
MH_32	32	24.00 - 31.98	12.00	32.00		X	X	X	X	X
MH_40	40	30.00 - 39.98	14.00	40.00		X	X	X	X	X

Material
 Steel: M2, HRC 60-63 X
 Alternate Available PM4, HRC 60-63 X

Standard Point Tolerance

Round P $\begin{matrix} +.01 \\ -.00 \end{matrix}$ ⊙ .01 P to D

Shape P, W $\pm .01$ ⊙ .02 P to D

When P = D Shank Tolerances apply

X Must Specify M2 or PM4 when ordering

CATALOG TYPE	SHANK D	SBR		
		STD	ALTERNATES	
		B	C	
MH_10	10	19	10	—
MH_13	13	19	13	25
MH_16	16	19	13	25
MH_20	20	19	13	25
MH_25	25	19	13	25
MH_32	32	19	13	25
MH_40	40	25	19	30

L=71 SBR MAX=19

STANDARD BALL SEAT LOCATION IS AT 90° AS SHOWN. AVAILABLE AT 0°, 180°, 270°, FOR SAME PRICE.

BALL LOCK PUNCHES



HEAVY DUTY/EJECTOR

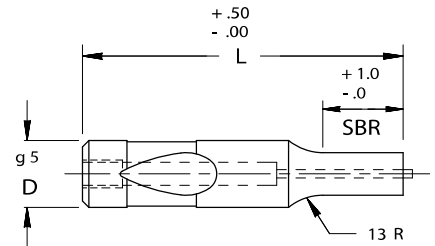
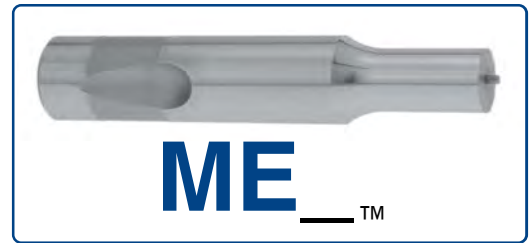
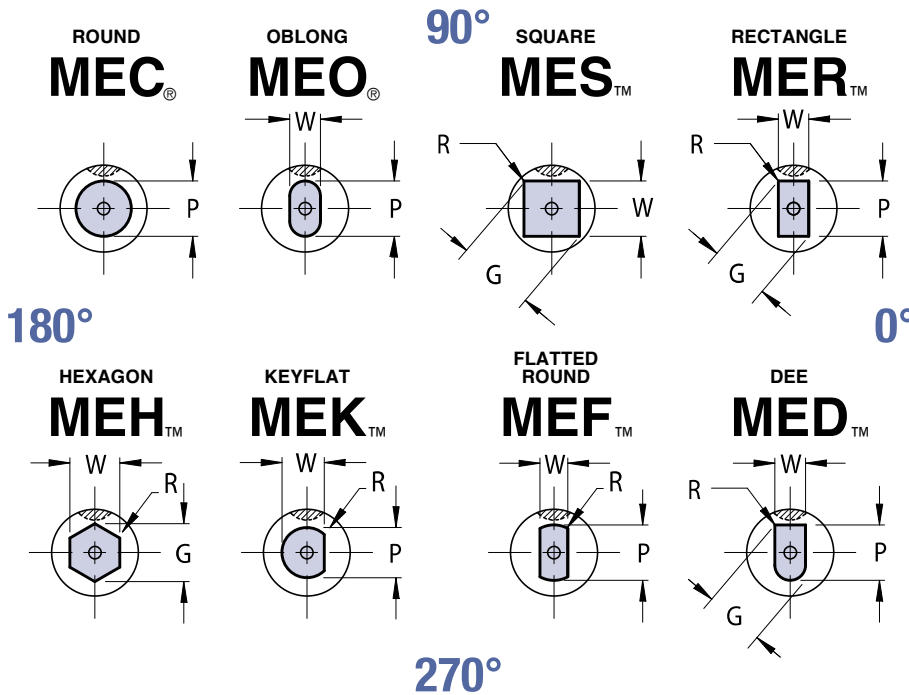

ORDER EXAMPLE:
 (Reference page 4)

SPECIFY:	QTY:	TYPE	"D"	"L"	POINT LENGTH	P(OR P&W) DIMENSIONS	MATERIAL
EXAMPLE:	6	MHC	13	90	C	8.0	M2
EXAMPLE:	6	MHO	16	80	STD	14.0 x 7.0	PM4

Note: When ordering, standard quantity breaks are: 1, 2-3, 4-11, 12-23, 24-49, 50-99

VIEWS ARE SHOWN LOOKING THROUGH THE SHANK BUT DRAWN WITH SOLID LINES FOR CLARITY. FOR PRODUCT ALTERATIONS SEE PAGES 74-80.

Complete design & CAD files visit WWW.MOELLERMCAD.COM

CATALOG TYPE	SHANK DIA D	ROUND	SHAPE		OVERALL LENGTH "L"						
		RANGE P	MIN W	MAX G/P	63	71	80	90	100	110	125
ME_10	10	2.50 - 9.98	2.50	10.00	X	X	X	X	X	X	
ME_13	13	5.00 - 12.98	4.50	13.00	X	X	X	X	X	X	X
ME_16	16	8.00 - 15.98	6.00	16.00	X	X	X	X	X	X	X
ME_20	20	12.00 - 19.98	8.00	20.00	X	X	X	X	X	X	X
ME_25	25	16.00 - 24.98	10.00	25.00			X	X	X	X	X
ME_32	32	24.00 - 31.98	12.00	32.00			X	X	X	X	X
ME_40	40	30.00 - 39.98	14.00	40.00			X	X	X	X	X

Material
 Steel: M2, HRC 60-63 X
 Alternate Available PM4, HRC 60-63 X

Standard Point Tolerance

Round P $\begin{matrix} +.01 \\ -.00 \end{matrix}$ ◎ .01 P to D

Shape P, W $\pm .01$ ◎ .02 P to D

When P = D Shank Tolerances apply

X Must Specify M2 or PM4 when ordering

CATALOG TYPE	SHANK D	SBR			EJECTOR SIZE
		STD	ALTERNATES		
	B		C		
ME_10	10	19	10	—	MAE 4
ME_13	13	19	13	25	MAE 5
ME_16	16	19	13	25	MAE 5
ME_20	20	19	13	25	MAE 6
ME_25	25	19	13	25	MAE 6
ME_32	32	19	13	25	MAE 6
ME_40	40	25	19	30	MAE 6

L=63 SBR MAX=19
 L=71 SBR MAX=19

XP ALTERATION NOT AVAILABLE
 IF L=63 AND SBR=19

STANDARD BALL SEAT LOCATION IS AT 90° AS SHOWN. AVAILABLE AT 0°, 180°, 270°, FOR SAME PRICE.

BALL LOCK PILOTS

HEAVY DUTY

STANDARD STYLE



BULLET NOSE STYLE

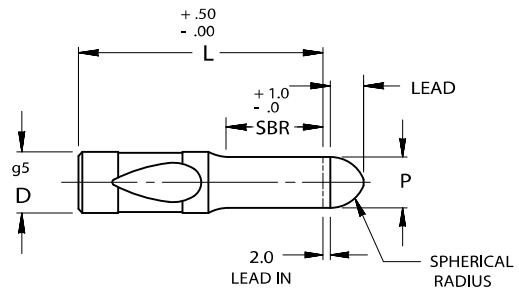
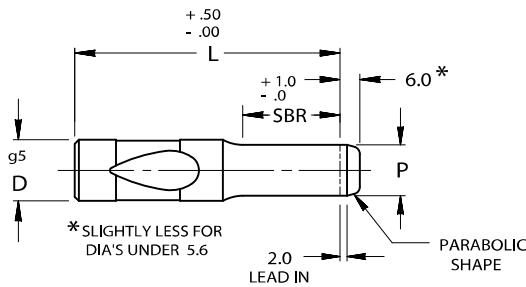

ORDER EXAMPLE:

(Reference page 4)

SPECIFY:	QTY:	TYPE	"D"	"L"	POINT LENGTH	"P" DIMENSION	MATERIAL
EXAMPLE:	6	MHT	20	80	B	16.0	M2
EXAMPLE:	6	MHP	13	90	STD	9.0	PM4

Note: When ordering, standard quantity breaks are: 1, 2-3, 4-11, 12-23, 24-49, 50-99

MHP STYLE LEAD

P DIM	LEAD
1.50-9.50	4
9.51-Above	10

FOR PRODUCT ALTERATIONS SEE PAGES 74-80.

Complete design & CAD files visit WWW.MOELLERMCAD.COM

CATALOG TYPE	SHANK DIA D	RANGE P	LENGTH "L"					
			71	80	90	100	110	125
MH_10	10	2.50 - 10.00	(X)	(X)	(X)	(X)	(X)	X
MH_13	13	5.00 - 13.00	(X)	(X)	(X)	(X)	(X)	X
MH_16	16	8.00 - 16.00	(X)	(X)	(X)	(X)	(X)	X
MH_20	20	12.00 - 20.00	(X)	(X)	(X)	(X)	(X)	X
MH_25	25	16.00 - 25.00		(X)	(X)	(X)	(X)	X
MH_32	32	24.00 - 32.00		(X)	(X)	(X)	(X)	X
MH_40	40	30.00 - 40.00		(X)	(X)	(X)	(X)	X

Material

Steel: M2, HRC 60-63 (X)

Alternate Available PM4, HRC 60-63 (X)

Standard Point Tolerance

Round P $+ .01$ / $- .00$

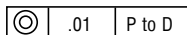

When P = D Shank Tolerances apply

(X) Must Specify M2 or PM4 when ordering

CATALOG TYPE	SHANK D	SBR		
		STD	ALTERNATES	
			B	C
MH_10	10	19	10	—
MH_13	13	19	13	25
MH_16	16	19	13	25
MH_20	20	19	13	25
MH_25	25	19	13	25
MH_32	32	19	13	25
MH_40	40	25	19	30

L=71 SBR MAX=19

BALL LOCK PILOTS

HEAVY DUTY

LONG LEAD STYLE

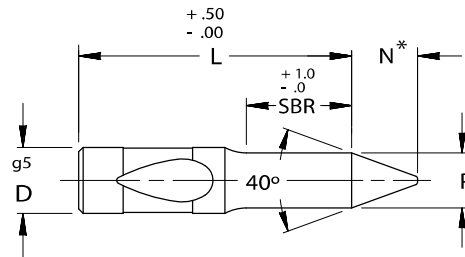

* N BECOMES 1.2 X P MIN
WHEN P IS BELOW
(SEE CHART)

ORDER EXAMPLE:

(Reference page 4)

SPECIFY:	QTY:	TYPE	"D"	"L"	POINT LENGTH	"P" DIMENSION	MATERIAL
EXAMPLE:	6	MHT	20	80	B	16.0	M2
EXAMPLE:	6	MHP	13	90	STD	9.0	PM4

Note: When ordering, standard quantity breaks are: 1, 2-3, 4-11, 12-23, 24-49, 50-99

Complete design & CAD files visit WWW.MOELLERMCAD.COM

FOR PRODUCT ALTERATIONS SEE PAGES 74-80.

CATALOG NUMBER	SHANK DIA D	RANGE P	LEAD N	P BELOW SEE NOTE*	LENGTH "L"						
					80	90	100	110	125	140	150
MHA 10	10	5.90 - 10.00	8	5.64	(X)	(X)	(X)	(X)	X		
MHA 13	13	9.90 - 13.00	10	7.11	(X)	(X)	(X)	(X)	X	X	
MHA 16	16	12.90 - 16.00	15	10.74	(X)	(X)	(X)	(X)	X	X	X
MHA 20	20	15.90 - 20.00	20	14.38	(X)	(X)	(X)	X	X	X	X
MHA 25	25	19.90 - 25.00	25	18.00	(X)	(X)	(X)	X	X	X	X
MHA 32	32	24.90 - 32.00	30	21.67	(X)	(X)	X	X	X	X	X
MHA 40	40	31.90 - 40.00	40	28.96	(X)	X	X	X	X	X	X

Material

Steel: M2, HRC 60-63

Alternate Available PM4, HRC 60-63

X

(X)

Standard Point Tolerance

Round P $\begin{matrix} +.01 \\ -.00 \end{matrix}$

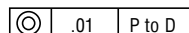

When P = D Shank Tolerances apply

(X) Must Specify M2 or PM4 when ordering

CATALOG TYPE	SHANK D	SBR	
		ALTERNATES	
		STD	B
MHA 10	10	19	32
MHA 13	13	19	32
MHA 16	16	25	38
MHA 20	20	25	38
MHA 25	25	25	38
MHA 32	32	25	38
MHA 40	40	30	45

NOTE: MUST MAINTAIN MINIMUM SHANK LENGTH OF 38MM.

BALL LOCK PUNCH BLANKS **MOELLER™** PRECISION TOOL

HEAVY DUTY/SOLID/EJECTOR

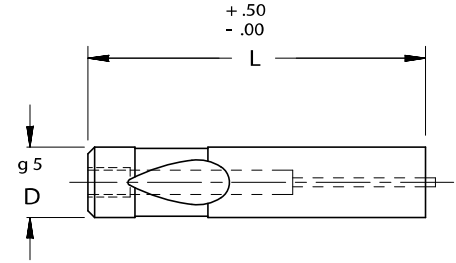
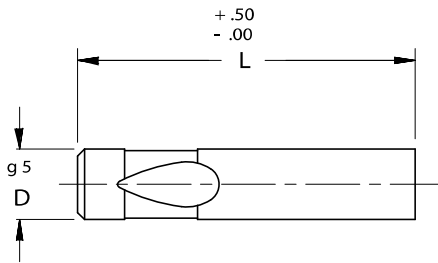

Material
Steel: M2, HRC 60-63 X
Alternate Available PM4, HRC 60-63 (X)
(X) Must Specify M2 or PM4 when ordering

ORDER EXAMPLE:
(Reference page 4)
SPECIFY: QTY: TYPE "D" "L" MATERIAL
EXAMPLE: 6 MHB 20 110 M2
EXAMPLE: 6 MEB 16 90 PM4

FOR PRODUCT ALTERATIONS SEE PAGES 74-80.

Complete design & CAD files visit WWW.MOELLERMCAD.COM

CATALOG NUMBER SOLID	SHANK DIA D	OVERALL LENGTH "L"											
		71	80	90	100	110	125	150	165	170	175	180	190
MHB 10	10	(X)	(X)	(X)	(X)	(X)	(X)	X					
MHB 13	13	(X)	(X)	(X)	(X)	(X)	(X)	X					
MHB 16	16	(X)	(X)	(X)	(X)	(X)	(X)	X	X				
MHB 20	20	(X)	(X)	(X)	(X)	(X)	(X)	X		X			
MHB 25	25		(X)	(X)	(X)	(X)	(X)	X			X		
MHB 32	32		(X)	(X)	(X)	(X)	(X)	X				X	
MHB 40	40		(X)	(X)	(X)	(X)	(X)	X					X

CATALOG NUMBER EJECTOR	SHANK DIA D	OVERALL LENGTH "L"							EJECTOR SIZE
		63	71	80	90	100	110	125	
MEB 10	10	(X)	(X)	(X)	(X)	(X)	(X)		MAE 4
MEB 13	13	(X)	(X)	(X)	(X)	(X)	(X)	(X)	MAE 5
MEB 16	16	(X)	(X)	(X)	(X)	(X)	(X)	(X)	MAE 5
MEB 20	20	(X)	(X)	(X)	(X)	(X)	(X)	(X)	MAE 6
MEB 25	25			(X)	(X)	(X)	(X)	(X)	MAE 6
MEB 32	32			(X)	(X)	(X)	(X)	(X)	MAE 6
MEB 40	40			(X)	(X)	(X)	(X)	(X)	MAE 6

NOSE LARGE PUNCHES



HEAVY DUTY/SOLID

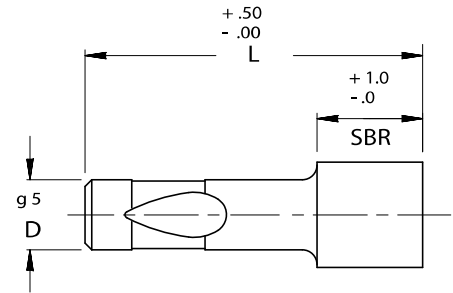
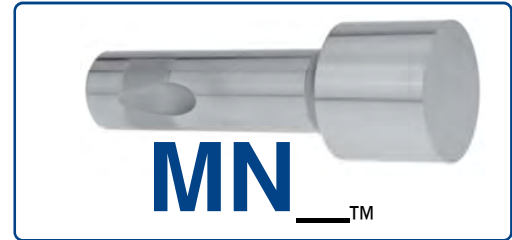
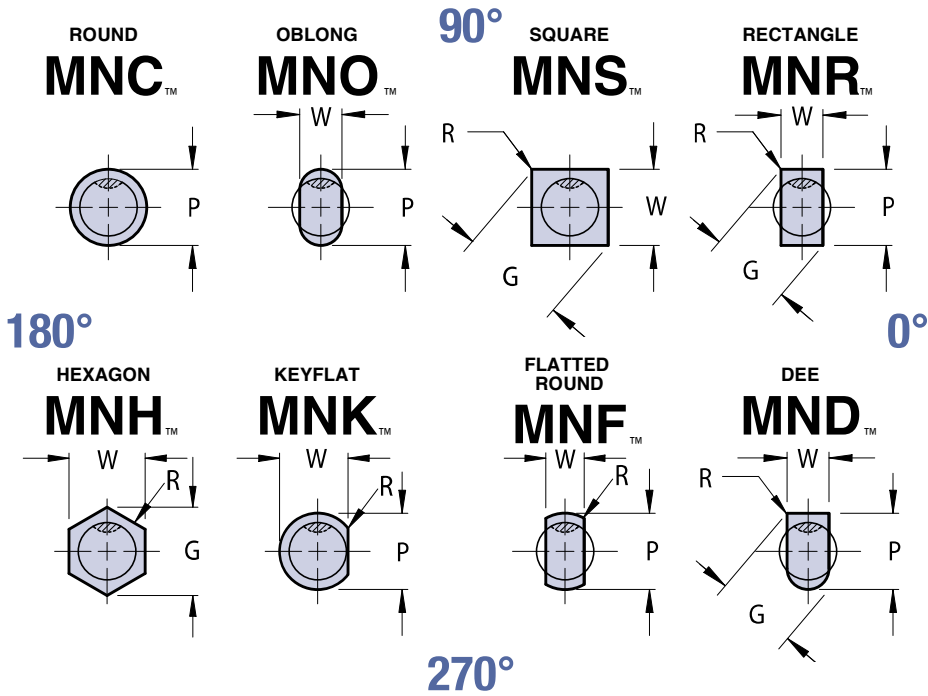

VIEWES ARE SHOWN LOOKING THROUGH THE SHANK BUT DRAWN WITH SOLID LINES FOR CLARITY.

ORDER EXAMPLE:
(Reference page 4)
SPECIFY: QTY: TYPE "D" "L" P(OR P&W) DIMENSIONS
EXAMPLE: 6 MNR 20 90 22.0 x 12.0
Note: When ordering, standard quantity breaks are: 1, 2-3, 4-11, 12-23, 24-49, 50-99

Complete design & CAD files visit WWW.MOELLERMCAD.COM

FOR PRODUCT ALTERATIONS SEE PAGES 74-80.

CATALOG TYPE	SHANK DIA D	POINT LENGTH "S.B.R."	ROUND	SHAPE		LENGTH "L"		
			RANGE P	MIN W	MAX G/P	80	90	100
MN_10	10	16	10.10 - 25.00	3.00	25.00	X	X	X
MN_13	13	20	13.10 - 32.00	5.00	32.00	X	X	X
MN_16	16	25	16.10 - 38.00	6.00	38.00	X	X	X
MN_20	20	25	20.10 - 40.00	8.00	40.00	X	X	X
MN_25	25	25	25.10 - 47.00	10.00	47.00	X	X	X
MN_32	32	32	32.10 - 63.00	11.50	63.00	X	X	X
MN_40	40	32	40.10 - 63.00	14.00	63.00	X	X	X

Material
 Steel: M2, HRC 60-63

Standard Point Tolerance

Round P $\begin{matrix} +.01 \\ -.00 \end{matrix}$ $\begin{matrix} \text{⊙} & .01 & \text{P to D} \\ \text{⊙} & .02 & \text{P to D} \end{matrix}$

Shape P, W $\pm .01$

STANDARD BALL SEAT LOCATION IS AT 90° AS SHOWN. AVAILABLE AT 0°, 180°, 270°, FOR SAME PRICE.

NOSE LARGE PUNCHES

HEAVY DUTY/EJECTOR

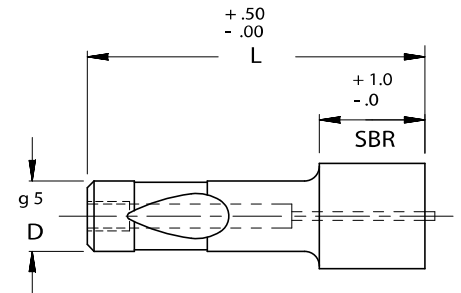
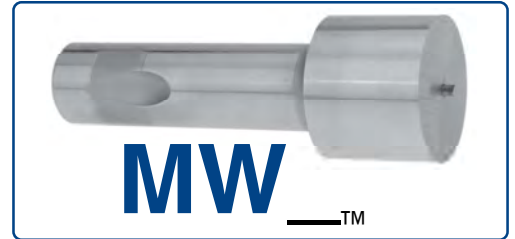
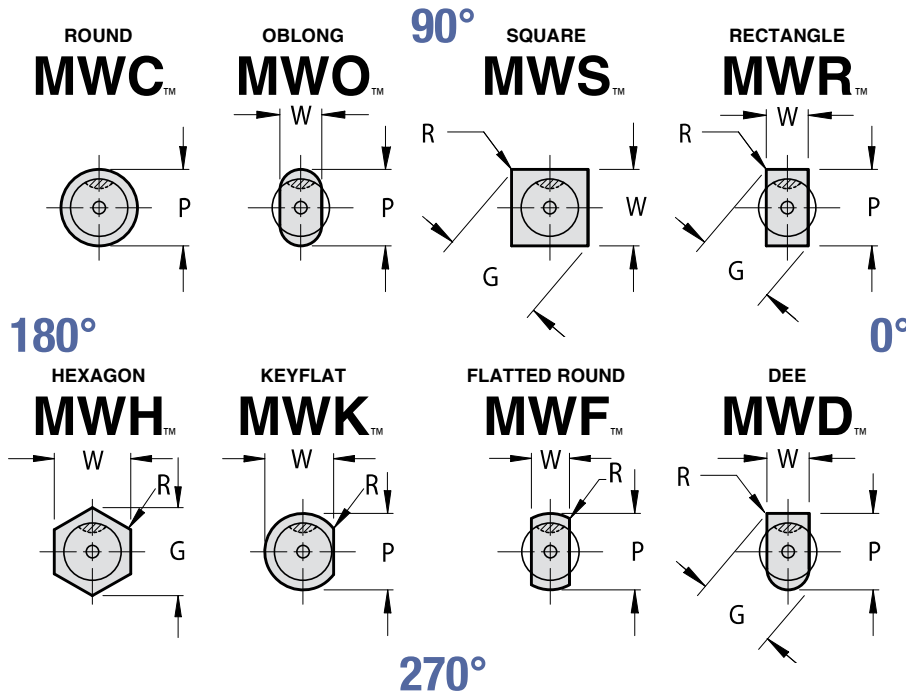

ORDER EXAMPLE:

(Reference page 4)

SPECIFY: QTY: TYPE "D" "L" P (OR P&W) DIMENSIONS
 EXAMPLE: 6 MWO 16 90 19.0 x 13.0

Note: When ordering, standard quantity breaks are: 1, 2-3, 4-11, 12-23, 24-49, 50-59

VIEWS ARE SHOWN LOOKING THROUGH THE SHANK BUT DRAWN WITH SOLID LINES FOR CLARITY.

Complete design & CAD files visit WWW.MOELLERMCAD.COM

FOR PRODUCT ALTERATIONS SEE PAGES 74-80.

CATALOG TYPE	SHANK DIA D	POINT LENGTH "S.B.R."	ROUND	SHAPE		OVERALL LENGTH "L"			EJECTOR SIZE
			RANGE P	MIN W	MAX G/P	80	90	100	
MW_10	10	16	10.10 - 25.00	3.00	25.00	X	X	X	MAE 4
MW_13	13	20	13.10 - 32.00	5.00	32.00	X	X	X	MAE 5
MW_16	16	25	16.10 - 38.00	6.00	38.00	X	X	X	MAE 5
MW_20	20	25	20.10 - 40.00	8.00	40.00	X	X	X	MAE 6
MW_25	25	25	25.10 - 47.00	10.00	47.00	X	X	X	MAE 6
MW_32	32	32	32.10 - 63.00	11.50	63.00	X	X	X	MAE 6
MW_40	40	32	40.10 - 63.00	14.00	63.00	X	X	X	MAE 6

Material

Steel: M2, HRC 60-63

Standard Point Tolerance

Round P $\begin{matrix} +.01 \\ -.00 \end{matrix}$

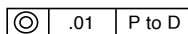

Shape P, W $\pm .01$

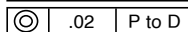

STANDARD BALL SEAT LOCATION IS AT 90° AS SHOWN. AVAILABLE AT 0°, 180°, 270°, FOR SAME PRICE.

BALL LOCK PUNCHES



LIGHT DUTY/SOLID

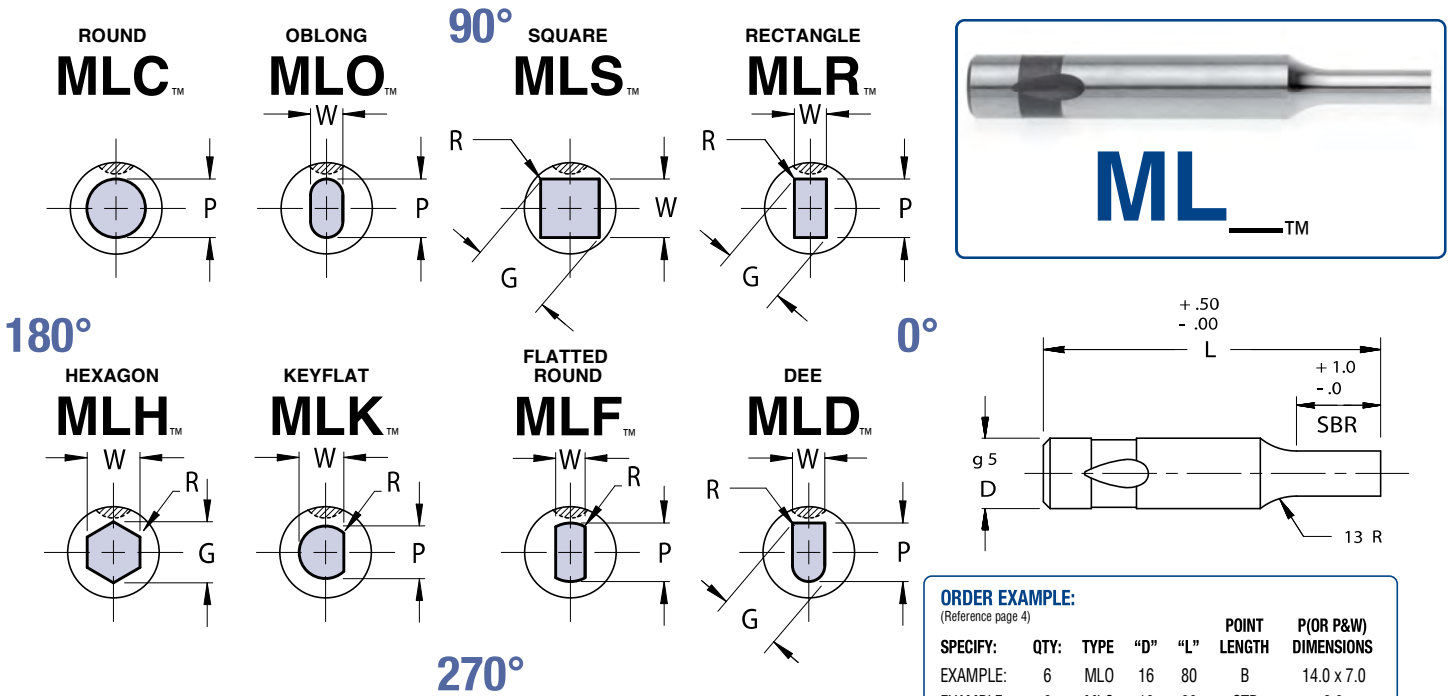

ORDER EXAMPLE:
(Reference page 4)

SPECIFY:	QTY:	TYPE	"D"	"L"	POINT LENGTH	P (OR P&W) DIMENSIONS
EXAMPLE:	6	MLO	16	80	B	14.0 x 7.0
EXAMPLE:	6	MLC	10	90	STD	8.0

Note: When ordering, standard quantity breaks are: 1, 2-3, 4-11, 12-23, 24-49, 50-99

VIEWS ARE SHOWN LOOKING THROUGH THE SHANK BUT DRAWN WITH SOLID LINES FOR CLARITY.

Complete design & CAD files visit WWW.MOELLERMCAD.COM

FOR PRODUCT ALTERATIONS SEE PAGES 74-80.

CATALOG TYPE	SHANK DIA D	ROUND	SHAPE		OVERALL LENGTH "L"				
		RANGE P	MIN W	MAX G/P	63	71	80	90	100
ML_06	6	2.20 - 5.98	2.20	6.00	X	X	X	X	X
ML_10	10	2.50 - 9.98	2.50	10.00	X	X	X	X	X
ML_13	13	5.00 - 12.98	4.50	13.00	X	X	X	X	X
ML_16	16	8.00 - 15.98	6.00	16.00	X	X	X	X	X
ML_20	20	12.00 - 19.98	8.00	20.00	X	X	X	X	X
ML_25	25	16.00 - 24.98	10.00	25.00	X	X	X	X	X

Material
 Steel: M2, HRC 60-63

Standard Point Tolerance

Round P $\begin{matrix} +.01 \\ -.00 \end{matrix}$ ⊙ .01 P to D

Shape P, W $\pm .01$ ⊙ .02 P to D

When P = D Shank Tolerances Apply

CATALOG TYPE	SHANK D	SBR		
		STD	ALTERNATES	
			B	C
ML_06	6	13	10	—
ML_10	10	19	10	—
ML_13	13	19	13	25
ML_16	16	19	13	25
ML_20	20	19	13	25
ML_25	25	19	13	25

L=63 SBR MAX=19

STANDARD BALL SEAT LOCATION IS AT 90° AS SHOWN. AVAILABLE AT 0°, 180°, 270°, FOR SAME PRICE.

BALL LOCK PUNCHES

LIGHT DUTY/EJECTOR

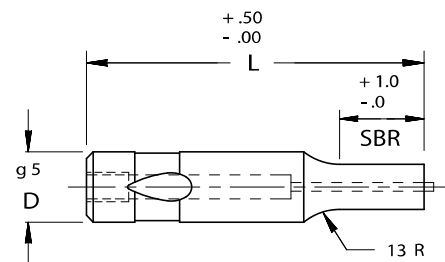
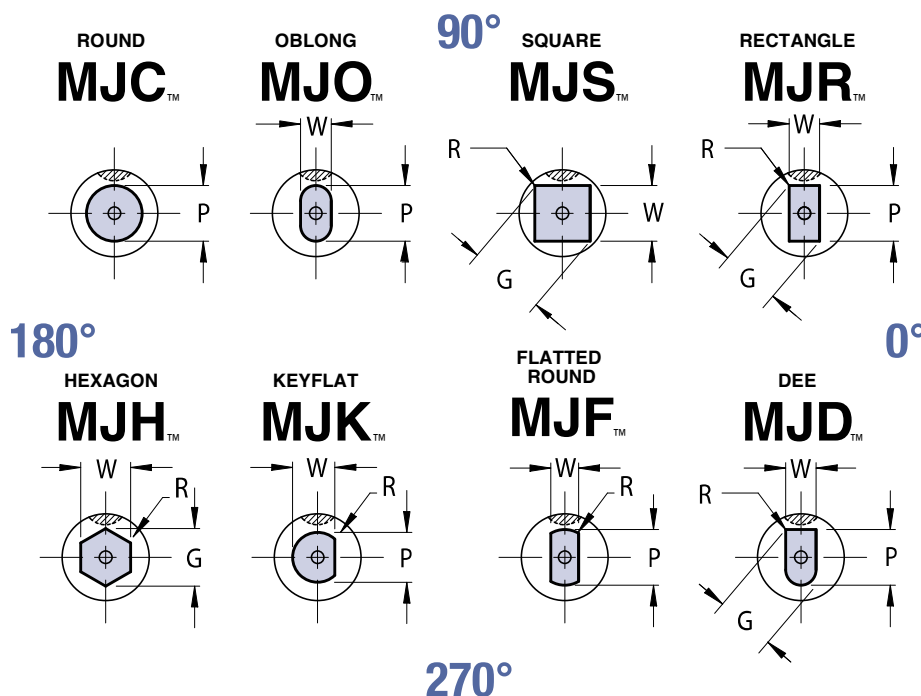

ORDER EXAMPLE:

(Reference page 4)

SPECIFY:	QTY:	TYPE	"D"	"L"	POINT LENGTH	P(OR P&W) DIMENSIONS
EXAMPLE:	6	MJC	16	90	STD	10.0
EXAMPLE:	6	MJO	13	80	B	10.0 x 7.0

Note: When ordering, standard quantity breaks are: 1, 2-3, 4-11, 12-23, 24-49, 50-99

VIEWS ARE SHOWN LOOKING THROUGH THE SHANK BUT DRAWN WITH SOLID LINES FOR CLARITY.

Complete design & CAD files visit WWW.MOELLERMCAD.COM

FOR PRODUCT ALTERATIONS SEE PAGES 74-80.

CATALOG TYPE	SHANK DIA D	ROUND	SHAPE		OVERALL LENGTH "L"				
		RANGE P	MIN W	MAX G/P	63	71	80	90	100
MJ_06	6	2.20 - 5.98	2.20	6.00	X	X	X	X	X
MJ_10	10	2.50 - 9.98	2.50	10.00	X	X	X	X	X
MJ_13	13	5.00 - 12.98	4.50	13.00	X	X	X	X	X
MJ_16	16	8.00 - 15.98	6.00	16.00	X	X	X	X	X
MJ_20	20	12.00 - 19.98	8.00	20.00	X	X	X	X	X
MJ_25	25	16.00 - 24.98	10.00	25.00	X	X	X	X	X

Material
Steel: M2, HRC 60-63

Standard Point Tolerance

Round P $\begin{matrix} +.01 \\ -.00 \end{matrix}$ ⊙ .01 P to D

Shape P, W $\pm .01$ ⊙ .02 P to D

When P = D Shank Tolerances Apply

CATALOG TYPE	SHANK D	SBR			EJECTOR SIZE
		STD	ALTERNATES		
			B	C	
MJ_06	6	13	10	—	MAE 3
MJ_10	10	19	10	—	MAE 4
MJ_13	13	19	13	25	MAE 5
MJ_16	16	19	13	25	MAE 5
MJ_20	20	19	13	25	MAE 6
MJ_25	25	19	13	25	MAE 6

L=63 SBR MAX=19
L=71 SBR MAX=19

STANDARD BALL SEAT LOCATION IS AT 90° AS SHOWN. AVAILABLE AT 0°, 180°, 270°, FOR SAME PRICE.

BALL LOCK PILOTS

LIGHT DUTY

STANDARD STYLE



BULLET NOSE STYLE



LONG LEAD STYLE

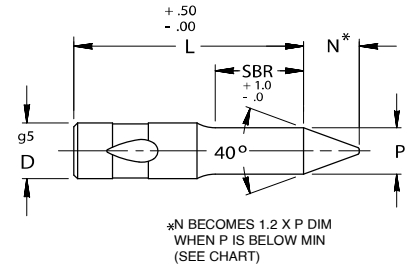
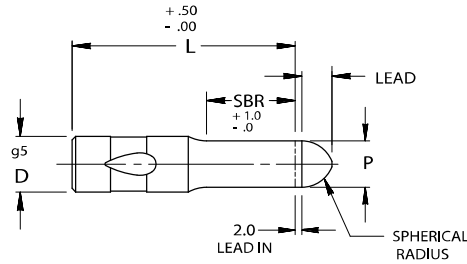
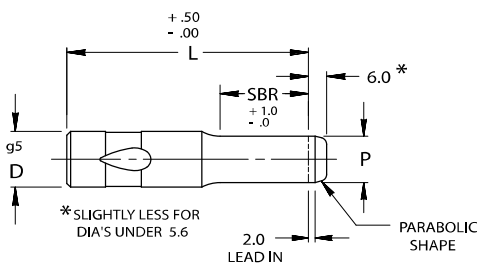

ORDER EXAMPLE:

(Reference page 4)

SPECIFY:	QTY:	TYPE	"D"	"L"	POINT LENGTH	"P" DIMENSIONS
EXAMPLE:	6	MLT	10	80	B	7.0
EXAMPLE:	6	MLA	13	90	STD	10.0

Note: When ordering, standard quantity breaks are: 1, 2-3, 4-11, 12-23, 24-49, 50-99

MLP STYLE LEAD

P DIM	LEAD
1.50-9.50	4
9.51-Above	10

SHANK DIA DIM	MLA STYLE N DIM
10	8
13	10
16	15
20	20
25	25

FOR PRODUCT ALTERATIONS SEE PAGES 74-80.

Complete design & CAD files visit WWW.MOELLERMCAD.COM

CATALOG TYPE	SHANK DIA D	RANGE	P BELOW SEE NOTE*	LENGTH "L"				
				63	71	80	90	100
ML_06	6	2.20 - 6.00	—	X	X	X	X	X
ML_10	10	2.50 - 10.00	5.64	X	X	X	X	X
ML_13	13	5.00 - 13.00	7.11	X	X	X	X	X
ML_16	16	8.00 - 16.00	10.74	X	X	X	X	X
ML_20	20	12.00 - 20.00	14.38	X	X	X	X	X
ML_25	25	16.00 - 25.00	18.00	X	X	X	X	X

Material

Steel: M2, HRC 60-63

Standard Point Tolerance

Round P $\begin{matrix} +.01 \\ -.00 \end{matrix}$

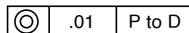

When P = D Shank Tolerances Apply

CATALOG TYPE	SHANK D	SBR		
		ALTERNATES		
		STD	B	C
ML_06	6	13	10	—
ML_10	10	19	10	—
ML_13	13	19	13	25
ML_16	16	19	13	25
ML_20	20	19	13	25
ML_25	25	19	13	25

L=63 SBR MAX=19

BALL LOCK PUNCH BLANKS **MOELLER**TM

PRECISION TOOL

LIGHT DUTY/SOLID/EJECTOR

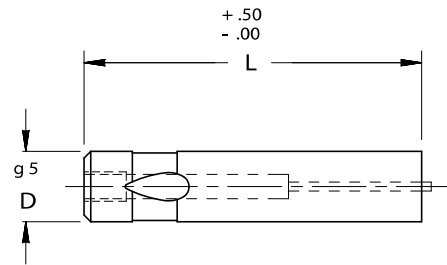
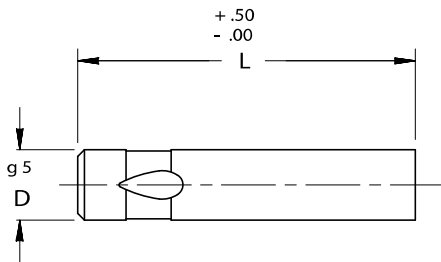

Material
Steel: M2, HRC 60-63

ORDER EXAMPLE:
(Reference page 4)

SPECIFY:	QTY:	TYPE	"D"	"L"
EXAMPLE:	6	MLB	20	90
EXAMPLE:	6	MJB	16	80

FOR PRODUCT ALTERATIONS SEE PAGES 74-80.

Complete design & CAD files visit WWW.MOELLERMCAD.COM

CATALOG NUMBER SOLID	SHANK DIA D	OVERALL LENGTH "L"					
		63	71	80	90	100	125
MLB 06	6	X	X	X	X	X	X
MLB 10	10	X	X	X	X	X	X
MLB 13	13	X	X	X	X	X	X
MLB 16	16	X	X	X	X	X	X
MLB 20	20	X	X	X	X	X	X
MLB 25	25	X	X	X	X	X	X

CATALOG NUMBER EJECTOR	SHANK DIA D	OVERALL LENGTH "L"					EJECTOR SIZE
		63	71	80	90	100	
MJB 06	6	X	X	X	X	X	MAE 3
MJB 10	10	X	X	X	X	X	MAE 4
MJB 13	13	X	X	X	X	X	MAE 5
MJB 16	16	X	X	X	X	X	MAE 5
MJB 20	20	X	X	X	X	X	MAE 6
MJB 25	25	X	X	X	X	X	MAE 6

NOSE LARGE PUNCHES



LIGHT DUTY/SOLID

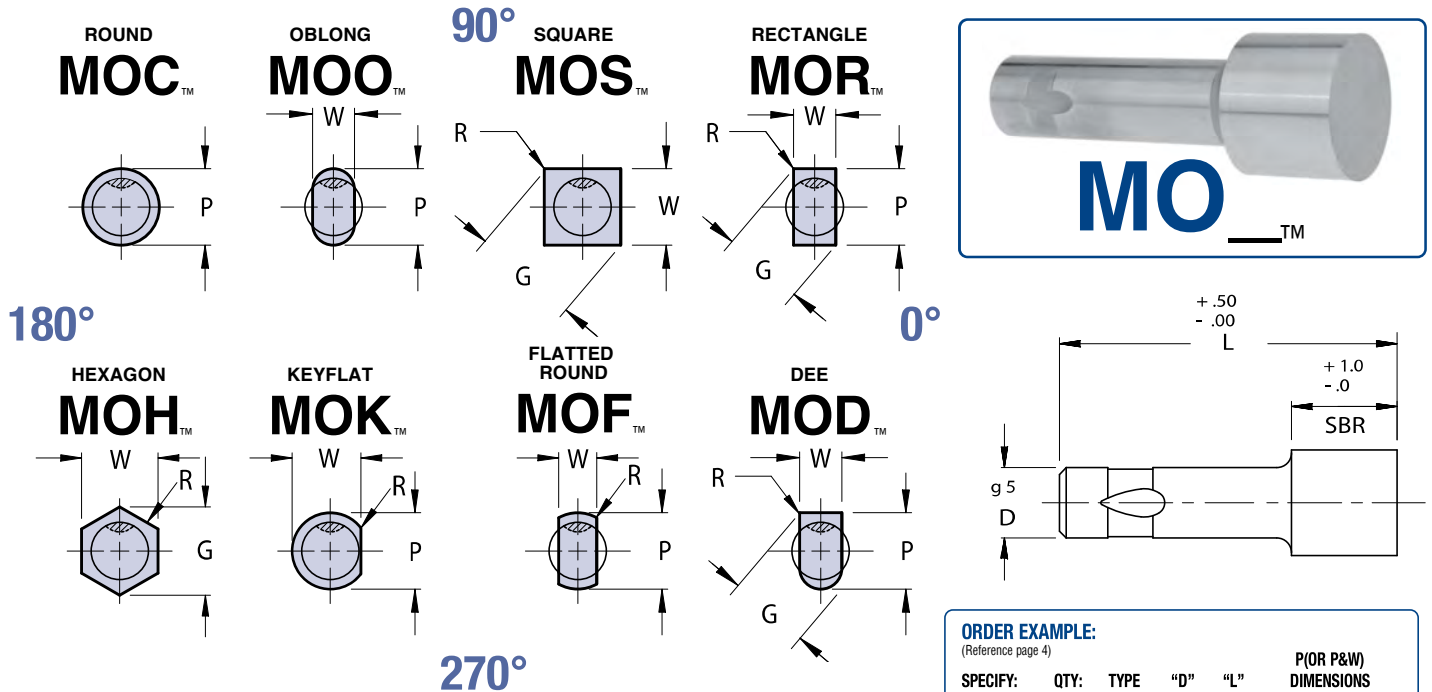

VIEWS ARE SHOWN LOOKING THROUGH THE SHANK BUT DRAWN WITH SOLID LINES FOR CLARITY.

ORDER EXAMPLE:
(Reference page 4)

SPECIFY:	QTY:	TYPE	"D"	"L"	P (OR P&W) DIMENSIONS
EXAMPLE:	6	MOO	16	90	22.0 x 11.0

Note: When ordering, standard quantity breaks are: 1, 2-3, 4-11, 12-23, 24-49, 50-99

Complete design & CAD files visit WWW.MOELLERMCAD.COM

FOR PRODUCT ALTERATIONS SEE PAGES 74-80.

CATALOG TYPE	SHANK DIA D	POINT LENGTH "S.B.R."	ROUND	SHAPE		LENGTH "L"		
			RANGE P	MIN W	MAX G/P	80	90	100
MO_10	10	16	10.10 - 25.00	3.00	25.00	X	X	X
MO_13	13	20	13.10 - 32.00	5.00	32.00	X	X	X
MO_16	16	25	16.10 - 38.00	6.00	38.00	X	X	X
MO_20	20	25	20.10 - 40.00	8.00	40.00	X	X	X
MO_25	25	25	25.10 - 47.00	10.00	47.00	X	X	X
MO_32	32	32	32.10 - 63.00	11.50	63.00	X	X	X

Material
 Steel: M2, HRC 60-63

Standard Point Tolerance

Round P $\begin{matrix} +.01 \\ -.00 \end{matrix}$ $\text{Ⓞ} \begin{matrix} .01 \\ P \text{ to } D \end{matrix}$

Shape P, W $\pm .01$ $\text{Ⓞ} \begin{matrix} .02 \\ P \text{ to } D \end{matrix}$

STANDARD BALL SEAT LOCATION IS AT 90° AS SHOWN. AVAILABLE AT 0°, 180°, 270°, FOR SAME PRICE.

NOSE LARGE PUNCHES

LIGHT DUTY/EJECTOR

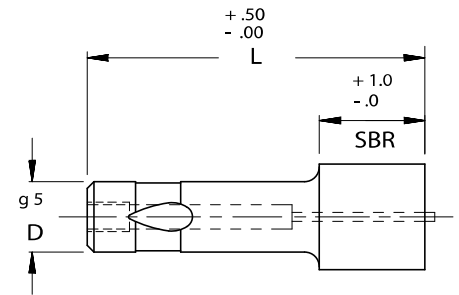
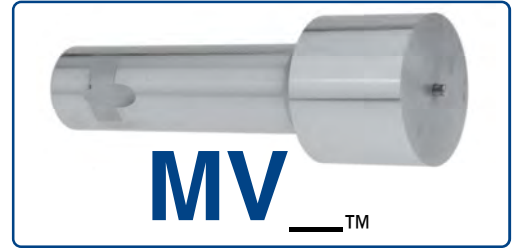
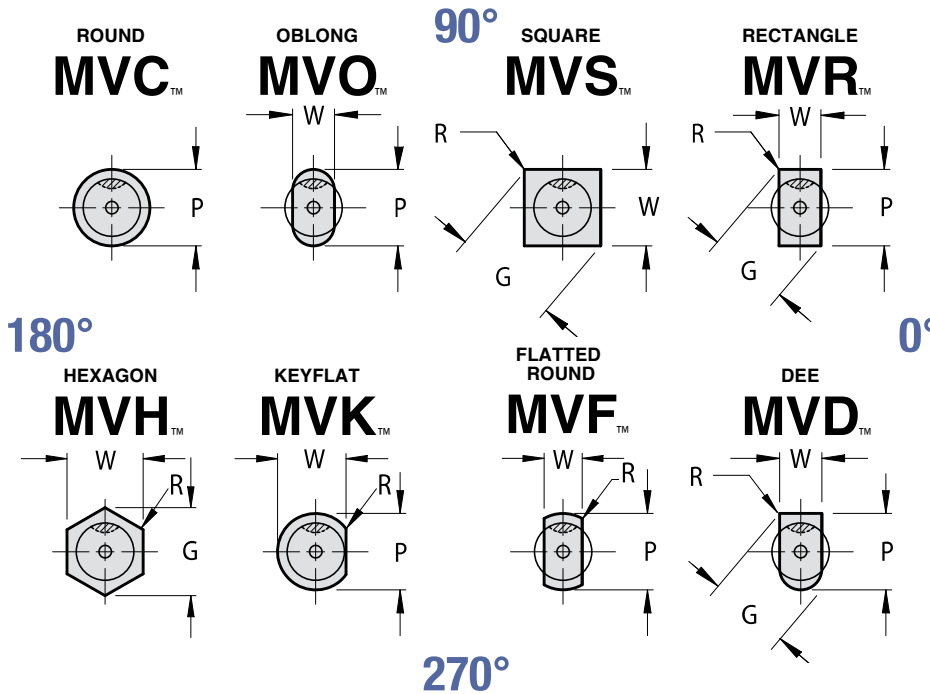

ORDER EXAMPLE:

(Reference page 4)

SPECIFY: QTY: TYPE "D" "L" P(OR P&W) DIMENSIONS
 EXAMPLE: 6 MVR 16 90 21.0 x 7.0

Note: When ordering, standard quantity breaks are: 1, 2-3, 4-11, 12-23, 24-49, 50-99

VIEWS ARE SHOWN LOOKING THROUGH THE SHANK BUT DRAWN WITH SOLID LINES FOR CLARITY.

Complete design & CAD files visit WWW.MOELLERMCAD.COM

FOR PRODUCT ALTERATIONS SEE PAGES 74-80.

CATALOG TYPE	SHANK DIA D	POINT LENGTH "S.B.R."	ROUND	SHAPE		LENGTH "L"			EJECTOR SIZE
			RANGE P	MIN W	MAX G/P	80	90	100	
MV_10	10	16	10.10 - 25.00	3.00	25.00	X	X	X	MAE 4
MV_13	13	20	13.10 - 32.00	5.00	32.00	X	X	X	MAE 5
MV_16	16	25	16.10 - 38.00	6.00	38.00	X	X	X	MAE 5
MV_20	20	25	20.10 - 40.00	8.00	40.00	X	X	X	MAE 6
MV_25	25	25	25.10 - 47.00	10.00	47.00	X	X	X	MAE 6
MV_32	32	32	32.10 - 63.00	11.50	63.00	X	X	X	MAE 6

Material

Steel: M2, HRC 60-63

Standard Point Tolerance

Round P $\pm .01$
 $-.00$

	.01	P to D
--	-----	--------

Shape P, W $\pm .01$

	.02	P to D
--	-----	--------

STANDARD BALL SEAT LOCATION IS AT 90° AS SHOWN. AVAILABLE AT 0°, 180°, 270°, FOR SAME PRICE.

SHOULDER PUNCHES



SOLID

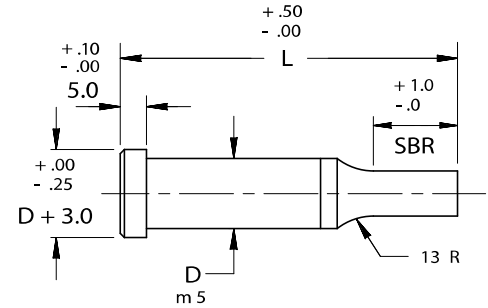
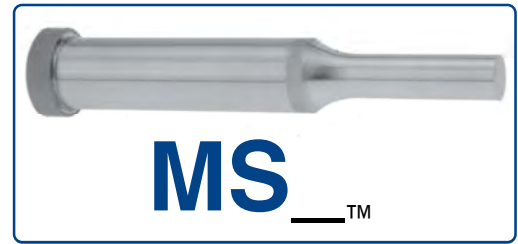
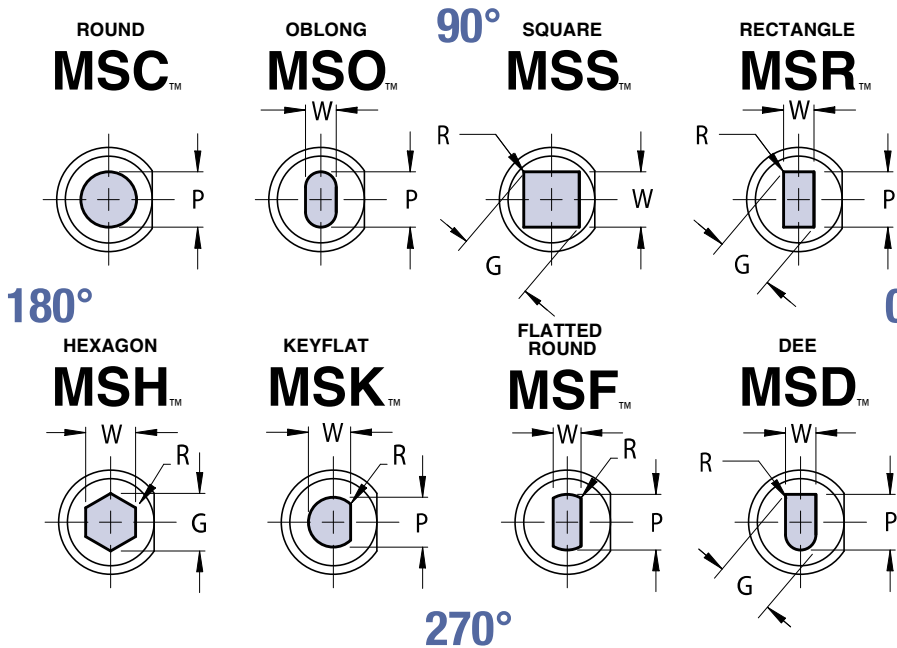

ORDER EXAMPLE:

(Reference page 4)

SPECIFY:	QTY:	TYPE:	"D"	"L"	POINT LENGTH	P(OR P&W) DIMENSIONS	ALTERATION CODE	ALTERNATE POINT TOLERANCE	MATERIAL
EXAMPLE:	6	MSC	13	90	13	10.0	F1	T2	PM4
EXAMPLE:	6	MSO	16	80	STD	14.0 x 8.0	F1	STD	PM4

Note: When ordering, standard quantity breaks are: 1, 2-3, 4-11, 12-23, 24-49, 50-99

VIEWS ARE SHOWN LOOKING THROUGH THE SHANK BUT DRAWN WITH SOLID LINES FOR CLARITY.

Complete design & CAD files visit WWW.MOELLERMCAD.COM

FOR PRODUCT ALTERATIONS SEE PAGES 74-80.

CATALOG TYPE	SHANK DIA D	ROUND RANGE P	SHAPE		OVERALL LENGTH "L"													
			MIN W	MAX G/P	40	50	56	60	63	70	71	80	90	100	110	120	125	150
MS_04	4	1.60 - 3.99	1.60	4.00	X	X	X	X	X	X	X	X	X	X		X	X	
MS_05	5	1.60 - 4.99	1.60	5.00	X	X	X	X	X	X	X	X	X	X		X	X	
MS_06	6	1.60 - 5.99	1.60	6.00		X	X	X	X	X	X	X	X	X		X	X	
MS_08	8	2.50 - 7.99	2.50	8.00		X	X	X	X	X	X	X	X	X	X	X	X	
MS_10	10	3.20 - 9.99	3.20	10.00		X	X	X	X	X	X	X	X	X	X	X	X	X
MS_13	13	5.00 - 12.99	4.50	13.00		X	X	X	X	X	X	X	X	X	X	X	X	X
MS_16	16	8.00 - 15.99	6.00	16.00		X	X	X	X	X	X	X	X	X	X	X	X	X
MS_20	20	10.00 - 19.99	8.00	20.00			X	X	X	X	X	X	X	X	X	X	X	X
MS_25	25	12.00 - 24.99	9.00	25.00			X	X	X	X	X	X	X	X	X	X	X	X
MS_32	32	16.00 - 31.99	10.00	32.00					X	X	X	X	X	X	X	X	X	X
MS_40	40	30.00 - 39.99	14.00	40.00								X	X	X	X		X	X

NOTE: FOR EXTENDED RANGE SHANK DIAMETERS OF 45, 50, 56 & 63, SEE PAGE NO. 21, 22.

X Must Specify M2 or PM4 when ordering

Material
 Steel: M2, HRC 60-63 **X**
 Alternate Available PM4, HRC 60-63 **X**
 Heads HRC 45-55

Standard Point Tolerance
 Round P $\begin{matrix} +.01 \\ -.00 \end{matrix}$ $\begin{matrix} \text{⊙} & .01 & \text{P to D} \\ \text{⊙} & .02 & \text{P to D} \end{matrix}$
 Shape P, W $\pm .01$
 When P = D Shank Tolerances apply

Alternate Point Tolerance **T2**

P, W TOLERANCE $\begin{matrix} +.005 \\ -.000 \end{matrix}$
 P to D $\begin{matrix} .008 & \text{⊙} \end{matrix}$

CATALOG TYPE	SHANK D	SBR		
		STD	ALTERNATES	
		B	C	
MS_04	4	8	10	—
MS_05	5	13	10	—
MS_06	6	13	10	—
MS_08	8	19	13	—
MS_10	10	19	13	25
MS_13	13	19	13	25
MS_16	16	19	13	25
MS_20	20	19	13	25
MS_25	25	19	13	25
MS_32	32	25	19	30
MS_40	40	25	19	30

STANDARD FLAT LOCATION IS AT 0° AS SHOWN.
 AVAILABLE AT 90°, 180°, 270°, FOR SAME ALTERATION PRICE.

L=50 SBR MAX=13 L=60 SBR MAX=19
 L=56 SBR MAX=19 L=63 SBR MAX=25

SHOULDER PUNCHES

EJECTOR

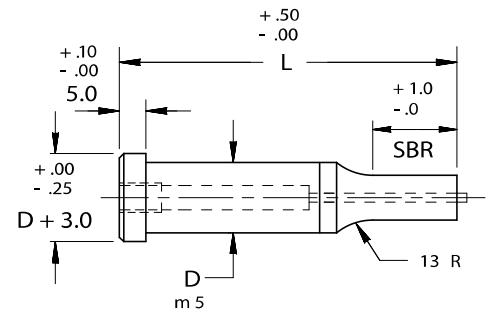
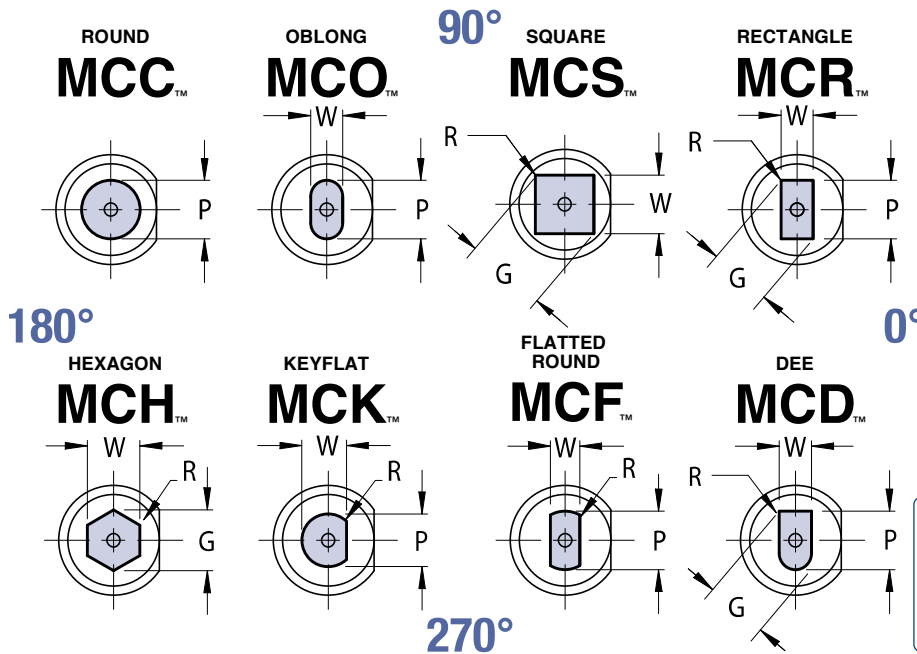
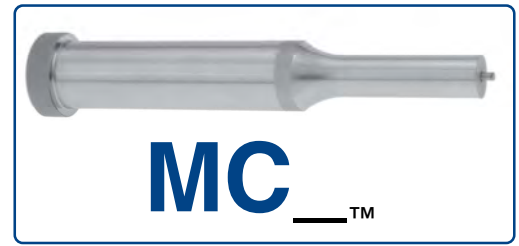

ORDER EXAMPLE:
 (Reference page 4)

SPECIFY:	QTY:	TYPE	"D"	"L"	POINT DIMENSIONS	P(OR P&W)	ALTERATION CODE	ALTERNATE POINT TOLERANCE	MATERIAL
EXAMPLE:	6	MCC	13	90	STD	10.0	F1	STD	M2
EXAMPLE:	6	MCD	16	80	B	13.0 x 9.0	F1	T2	PM4

Note: When ordering, standard quantity breaks are: 1, 2-3, 4-11, 12-23, 24-49, 50-99

VIEWS ARE SHOWN LOOKING THROUGH THE SHANK BUT DRAWN WITH SOLID LINES FOR CLARITY.
 Complete design & CAD files visit WWW.MOELLERMCAD.COM

FOR PRODUCT ALTERATIONS SEE PAGES 74-80.

CATALOG TYPE	SHANK DIA D	ROUND RANGE P	SHAPE		OVERALL LENGTH "L"											
			MIN W	MAX G/P	50	56	60	63	70	71	80	90	100	110	125	
MC_05	5	1.60 - 4.99	1.60	5.00	X	X	X	X	X	X	X	X	X	X		
MC_06	6	2.50 - 5.99	2.50	6.00	X	X	X	X	X	X	X	X	X	X		
MC_08	8	3.20 - 7.99	3.20	8.00	X	X	X	X	X	X	X	X	X	X	X	X
MC_10	10	4.50 - 9.99	4.50	10.00	X	X	X	X	X	X	X	X	X	X	X	X
MC_13	13	6.00 - 12.99	6.00	13.00	X	X	X	X	X	X	X	X	X	X	X	X
MC_16	16	8.00 - 15.99	7.50	16.00	X	X	X	X	X	X	X	X	X	X	X	X
MC_20	20	10.00 - 19.99	8.00	20.00		X	X	X	X	X	X	X	X	X	X	X
MC_25	25	12.00 - 24.99	9.00	25.00		X	X	X	X	X	X	X	X	X	X	X
MC_32	32	16.00 - 31.99	10.00	32.00				X	X	X	X	X	X	X	X	X
MC_40	40	30.00 - 39.99	14.00	40.00							X	X	X	X	X	X

NOTE: FOR EXTENDED RANGE SHANK DIAMETERS OF 45, 50, 56 & 63, SEE PAGE NO. 21, 22.

X Must Specify M2 or PM4 when ordering

Material
 Steel: M2, HRC 60-63 X
 Alternate Available PM4, HRC 60-63 X
 Heads HRC 45-55

Standard Point Tolerance

Round P $+0.01$ / $-.00$ Ⓢ .01 P to D

Shape P, W $\pm .01$ Ⓢ .02 P to D

When P = D Shank Tolerances apply

Alternate Point Tolerance **T2**

P, W TOLERANCE $+0.005$ / $-.000$

P to D Ⓢ .008 Ⓢ

CATALOG TYPE	SHANK D	SBR			EJECTOR SIZE
		ALTERNATES			
		STD	B	C	
MC_05	5	13	10	—	MAE 2
MC_06	6	13	10	—	MAE 3
MC_08	8	19	13	—	MAE 4
MC_10	10	19	13	25	MAE 5
MC_13	13	19	13	25	MAE 5
MC_16	16	19	13	25	MAE 6
MC_20	20	19	13	25	MAE 6
MC_25	25	19	13	25	MAE 6
MC_32	32	25	19	30	MAE 6
MC_40	40	25	19	30	MAE 6

STANDARD FLAT LOCATION IS AT 0° AS SHOWN.
 AVAILABLE AT 90°, 180°, 270°, FOR SAME ALTERATION PRICE.

L=50 SBR MAX=13 L=60 SBR MAX=19
 L=56 SBR MAX=19 L=63 SBR MAX=25

LARGE SHOULDER PUNCHES



SOLID/EXTENDED RANGE

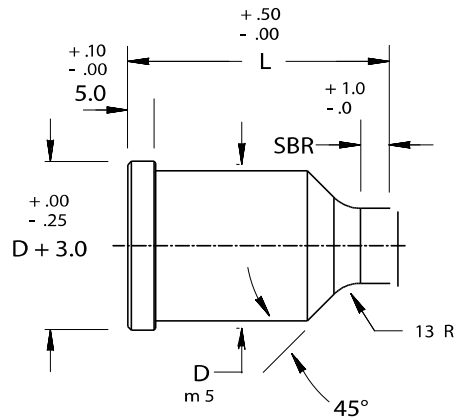
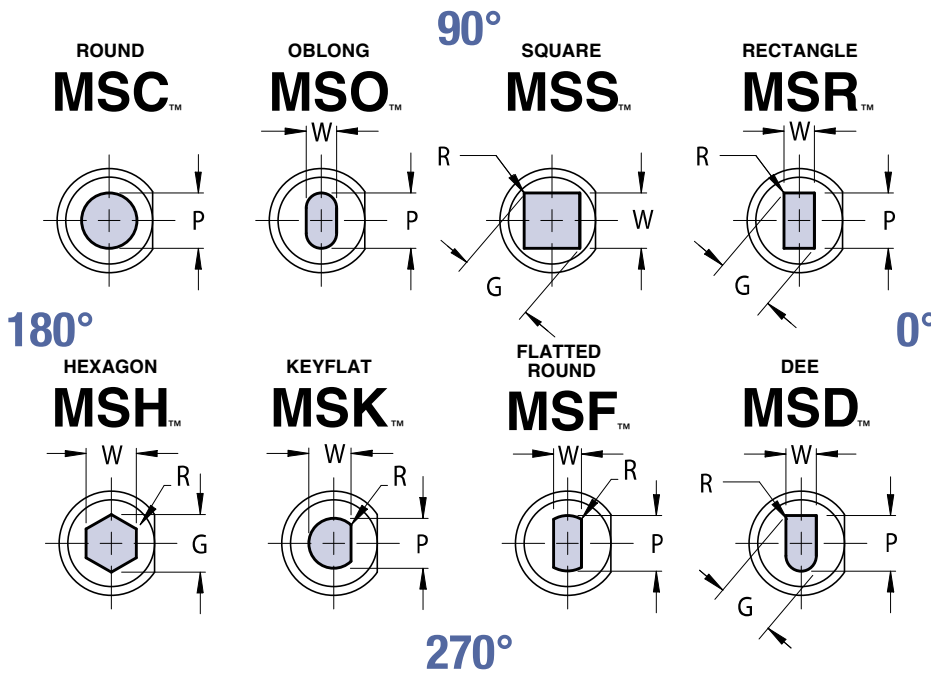
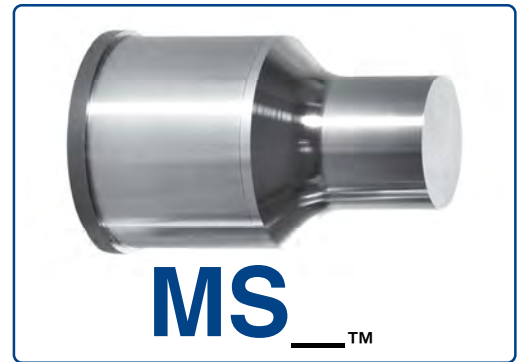

VIEWS ARE SHOWN LOOKING THROUGH THE SHANK BUT DRAWN WITH SOLID LINES FOR CLARITY.

Complete design & CAD files visit WWW.MOELLERMCAD.COM

FOR PRODUCT ALTERATIONS SEE PAGES 74-80.

CATALOG TYPE	SHANK DIA D	ROUND	SHAPES		OVERALL LENGTH "L"			SBR		
		RANGE P	MIN W	MAX G/P	80	90	100	ALTERNATES		
					STD	B	C			
MS_45	45	25.00 - 44.99	10.00	45.00	X	X	X	25	19	30
MS_50	50	30.00 - 49.99	12.00	50.00	X	X	X	25	19	30
MS_56	56	35.00 - 55.99	13.00	56.00	X	X	X	25	19	30
MS_63	63	40.00 - 62.99	14.00	63.00	X	X	X	25	19	30

Material

Steel: M2, HRC 60-63

Standard Point Tolerance

Round P	+ .01 - .00		.01	P to D
Shape P, W	± .01		.02	P to D

ORDER EXAMPLE:

(Reference page 4)

SPECIFY:	QTY:	TYPE	"D"	"L"	POINT LENGTH	P(OR P&W) DIMENSIONS	ALTERATION CODE	ALTERNATE POINT TOLERANCE
EXAMPLE:	6	MSC	50	90	STD	40.0	F1	STD
EXAMPLE:	6	MSO	63	100	B	50.0 x 20.0	F1	T2

Note: When ordering, standard quantity breaks are: 1, 2-3, 4-11, 12-23, 24-49, 50-99

STANDARD FLAT LOCATION IS AT 0° AS SHOWN. AVAILABLE AT 90°, 180°, 270°, FOR SAME ALTERATION PRICE

LARGE SHOULDER PUNCHES



EJECTOR/EXTENDED RANGE

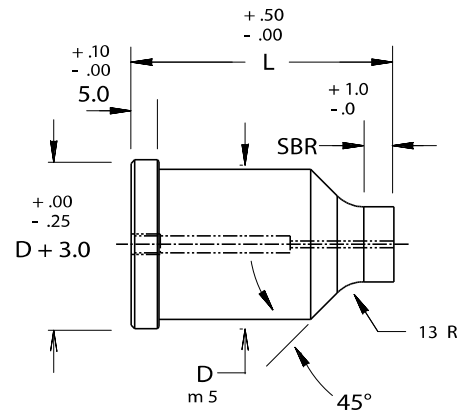
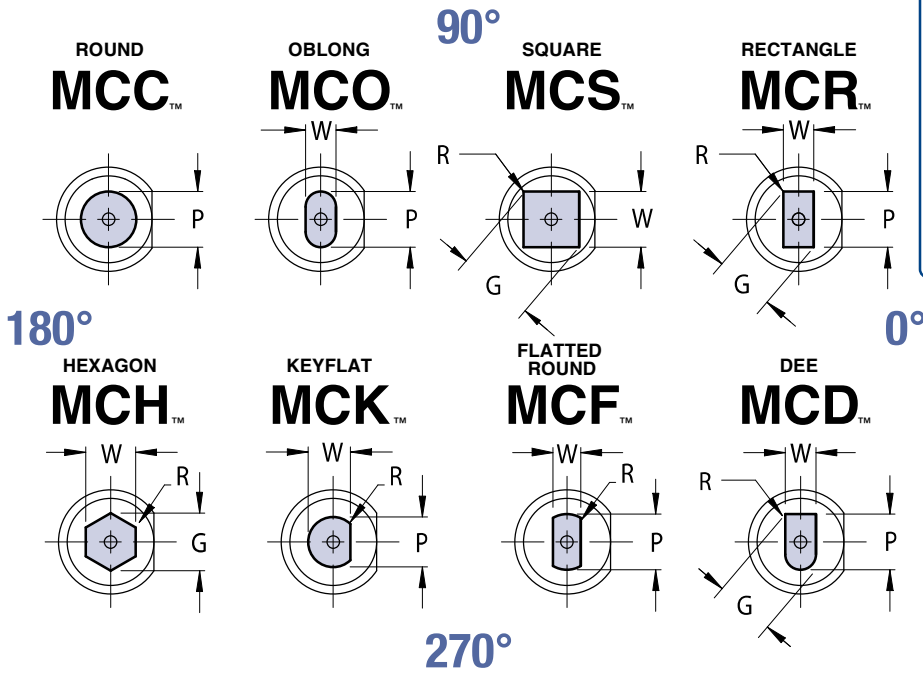
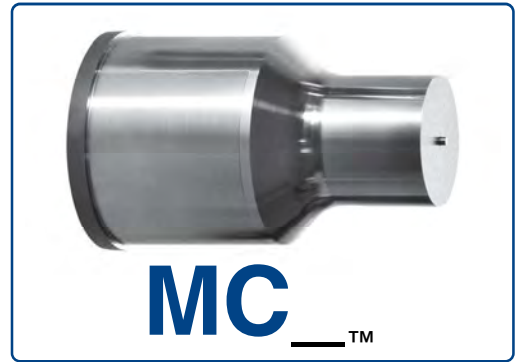

VIEWS ARE SHOWN LOOKING THROUGH THE SHANK BUT DRAWN WITH SOLID LINES FOR CLARITY.

Complete design & CAD files visit WWW.MOELLERMCAD.COM

FOR PRODUCT ALTERATIONS SEE PAGES 74-80.

CATALOG TYPE	SHANK DIA D	ROUND RANGE P	SHAPES		OVERALL LENGTH "L"			SBR			EJECTOR SIZE
			MIN W	MAX G/P	80	90	100	ALTERNATES			
								STD	B	C	
MC_45	45	25.00 - 44.99	10.00	45.00	X	X	X	25	19	30	MAE 12
MC_50	50	30.00 - 49.99	12.00	50.00	X	X	X	25	19	30	MAE 12
MC_56	56	35.00 - 55.99	13.00	56.00	X	X	X	25	19	30	MAE 12
MC_63	63	40.00 - 62.99	14.00	63.00	X	X	X	25	19	30	MAE 12

Material

Steel: M2, HRC 60-63

Standard Point Tolerance

Round P	+ .01 - .00		.01	P to D
Shape P, W	± .01		.02	P to D

ORDER EXAMPLE:

(Reference page 4)

SPECIFY:	QTY:	TYPE	"D"	"L"	POINT LENGTH	P(OR P&W) DIMENSIONS	ALTERATION CODE	ALTERNATE POINT TOLERANCE
EXAMPLE:	6	MCC	50	90	STD	40.0	F1	STD
EXAMPLE:	6	MCO	63	100	B	50.0 x 20.0	F1	T2

Note: When ordering, standard quantity breaks are: 1, 2-3, 4-11, 12-23, 24-49, 50-99

STANDARD FLAT LOCATION IS AT 0° AS SHOWN.
AVAILABLE AT 90°, 180°, 270°, FOR SAME ALTERATION PRICE.

SHOULDER PILOTS

PILOT

STANDARD STYLE

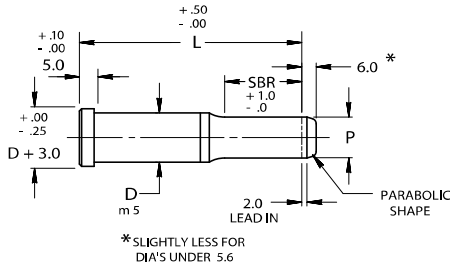

BULLET NOSE STYLE

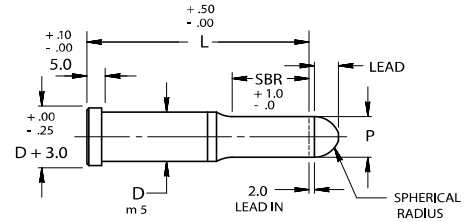

ORDER EXAMPLE:

(Reference page 4)

SPECIFY:	QTY:	TYPE	"D"	"L"	POINT LENGTH	"P" DIMENSION	ALTERNATE TOLERANCE	MATERIAL
EXAMPLE:	6	MST	13	71	STD	10.0	T2	PM4
EXAMPLE:	6	MSP	20	80	B	18.0	STD	M2

Note: When ordering, standard quantity breaks are: 1, 2-3, 4-11, 12-23, 24-49, 50-99

MSP STYLE LEAD

P DIM	LEAD
1.50-9.50	4
9.51-Above	10

FOR PRODUCT ALTERATIONS SEE PAGES 74-80.

Complete design & CAD files visit WWW.MOELLERMCAD.COM

CATALOG TYPE	SHANK DIA D	RANGE P	OVERALL LENGTH "L"										
			40	50	56	60	63	70	71	80	90	100	
MS_04	4	1.55 - 4.00	X	X	X	X	X	X	X	X	X	X	X
MS_05	5	1.55 - 5.00	X	X	X	X	X	X	X	X	X	X	X
MS_06	6	1.55 - 6.00		X	X	X	X	X	X	X	X	X	X
MS_08	8	2.45 - 8.00		X	X	X	X	X	X	X	X	X	X
MS_10	10	3.15 - 10.00		X	X	X	X	X	X	X	X	X	X
MS_13	13	4.95 - 13.00		X	X	X	X	X	X	X	X	X	X
MS_16	16	7.95 - 16.00		X	X	X	X	X	X	X	X	X	X
MS_20	20	9.95 - 20.00			X	X	X	X	X	X	X	X	X
MS_25	25	11.95 - 25.00			X	X	X	X	X	X	X	X	X
MS_32	32	15.95 - 32.00					X	X	X	X	X	X	X

Material
 Steel: M2, HRC 60-63 X
 Alternate Available PM4, HRC 60-63 X
 Heads HRC 45-55

Standard Point Tolerance
 Round P +.01
 -.00 .01 P to D

When P = D Shank Tolerances apply

X Must Specify M2 or PM4 when ordering

Alternate Point Tolerance T2

P, W TOLERANCE +.005
 -.000

P to D .008

CATALOG TYPE	SHANK D	SBR		
		ALTERNATES		
		STD	B	C
MS_04	4	8	10	—
MS_05	5	13	10	—
MS_06	6	13	10	—
MS_08	8	19	13	—
MS_10	10	19	13	25
MS_13	13	19	13	25
MS_16	16	19	13	25
MS_20	20	19	13	25
MS_25	25	19	13	25
MS_32	32	25	19	30

L=50 SBR MAX=13 L=60 SBR MAX=19
 L=56 SBR MAX=19 L=63 SBR MAX=25

SHOULDER PILOTS

PILOT

LONG LEAD STYLE

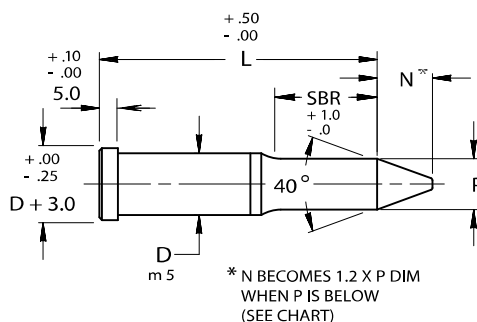

Complete design & CAD files visit WWW.MOELLERMCAD.COM

FOR PRODUCT ALTERATIONS SEE PAGES 74-80.

CATALOG TYPE	SHANK DIA D	RANGE P	LEAD N	P BELOW SEE NOTE*	LENGTH "L"								
					63	70	71	80	90	100	110	125	140
MS_10	10	4.85 - 10.00	8	5.64	(X)	(X)	(X)	(X)	(X)	X	X		
MS_13	13	6.30 - 13.00	10	7.11	(X)	(X)	(X)	(X)	X	X	X	X	X
MS_16	16	9.95 - 16.00	15	10.74		(X)	(X)	(X)	X	X	X	X	X
MS_20	20	13.60 - 20.00	20	14.38		(X)	(X)	(X)	X	X	X	X	X
MS_25	25	17.25 - 25.00	25	18.00		(X)	(X)	(X)	X	X	X	X	X
MS_32	32	20.85 - 32.00	30	21.67			(X)	(X)	X	X	X	X	X

Material
 Steel: M2, HRC 60-63
 Alternate Available PM4, HRC 60-63
 Heads HRC 45-55

Standard Point Tolerance
 Round P $\begin{matrix} +.01 \\ -.00 \end{matrix}$.01 P to D
 When P = D Shank Tolerances apply

Must Specify M2 or PM4 when ordering

Alternate Point Tolerance **T2**
 P, W TOLERANCE $\begin{matrix} +.005 \\ -.000 \end{matrix}$
 P to D .008

CATALOG TYPE	SHANK D	SBR	
		STD	ALTERNATES B
MS_10	10	19	25
MS_13	13	19	25
MS_16	16	19	25
MS_20	20	19	25
MS_25	25	19	25
MS_32	32	25	30

ORDER EXAMPLE:
 (Reference page 4)

SPECIFY:	QTY:	TYPE	"D"	"L"	POINT LENGTH	"P" DIMENSION	ALTERNATE TOLERANCE	MATERIAL
EXAMPLE:	6	MSA	20	90	STD	17.0	STD	M2
EXAMPLE:	6	MSA	20	90	STD	17.0	STD	PM4

Note: When ordering, standard quantity breaks are: 1, 2-3, 4-11, 12-23, 24-49, 50-99

SHOULDER PILOTS

PILOT/COMPACT/POINTED

POINTED STYLE

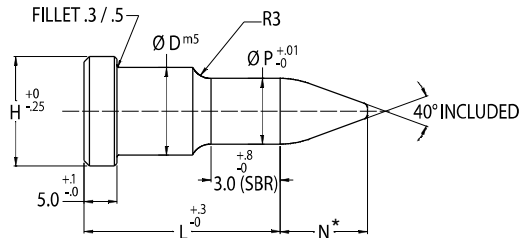

* N BECOMES 1.2 X P DIM
WHEN P IS BELOW
(SEE CHART)

Complete design & CAD files visit WWW.MOELLERMCAD.COM

FOR PRODUCT ALTERATIONS SEE PAGES 74-80.

CATALOG NUMBER POINTED	SHANK DIA D	DIA P RANGE	LEAD N	P BELOW SEE NOTE	H	OVERALL LENGTH "L"						
						16	20	22	25	28	32	35
MSW 04	4	1.95 - 3.99	4	4.00	7.0	X	X	X	X	X	X	X
MSW 05	5	2.65 - 4.99	5	4.19	8.0	X	X	X	X	X	X	X
MSW 06	6	3.30 - 5.99	6	4.19	9.0	X	X	X	X	X	X	X
MSW 08	8	4.10 - 7.99	7	4.19	11.0	X	X	X	X	X	X	X
MSW 10	10	4.80 - 9.99	8	5.64	13.0	X	X	X	X	X	X	X
MSW 13	13	6.25 - 12.99	10	7.11	16.0	X	X	X	X	X	X	X
MSW 16	16	9.85 - 15.99	15	10.74	19.0	X	X	X	X	X	X	X
MSW 20	20	13.50 - 19.99	20	14.38	23.0		X	X	X	X	X	X
MSW 25	25	17.20 - 24.99	25	18.00	28.0		X	X	X	X	X	X
MSW 32	32	20.80 - 31.99	30	21.67	35.0		X	X	X	X	X	X

Material

Steel: M2, HRC 60-63

Standard Point Tolerance

Round P $\begin{matrix} +.01 \\ -.00 \end{matrix}$.01 P to D

When P = D Shank Tolerances Apply

Alternate Point Tolerance

T2

P, W TOLERANCE $\begin{matrix} +.005 \\ -.000 \end{matrix}$

P to D $\begin{matrix} .008 \\ \text{tolerance symbol} \end{matrix}$

ORDER EXAMPLE:

(Reference page 4)

"p" ALTERNATE
SPECIFY: QTY: TYPE "D" "L" DIMENSION TOLERANCE

EXAMPLE: 6 MSW 13 25 10.0 STD

Note: When ordering, standard quantity breaks are:
1, 2-3, 4-11, 12-23, 24-49, 50-99

SHOULDER PILOTS

PILOT/COMPACT/STRAIGHT

STRAIGHT STYLE

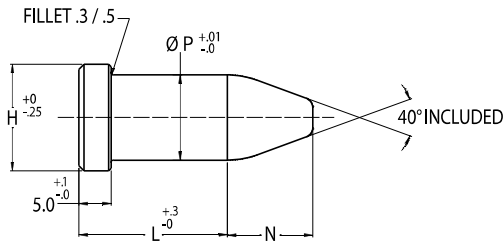

FOR PRODUCT ALTERATIONS SEE PAGES 74-80.

Complete design & CAD files visit WWW.MOELLERMCAD.COM

CATALOG NUMBER STRAIGHT	DIA P RANGE	LEAD N	H	OVERALL LENGTH "L"						
				16	20	22	25	28	32	35
MSV 04	3.01 - 4.00	4	7.0	X	X	X	X	X	X	X
MSV 05	4.01 - 5.00	5	8.0	X	X	X	X	X	X	X
MSV 06	5.01 - 6.00	6	9.0	X	X	X	X	X	X	X
MSV 08	6.01 - 8.00	7	11.0	X	X	X	X	X	X	X
MSV 10	8.01 - 10.00	8	13.0	X	X	X	X	X	X	X
MSV 13	10.01 - 13.00	10	16.0	X	X	X	X	X	X	X
MSV 16	13.01 - 16.00	15	19.0	X	X	X	X	X	X	X
MSV 20	16.01 - 20.00	20	23.0		X	X	X	X	X	X

Material

Steel: M2, HRC 60-63

Standard Point Tolerance

Round P $\begin{matrix} +.01 \\ -.00 \end{matrix}$.01 P to D

Alternate Point Tolerance

T2

P, W TOLERANCE $\begin{matrix} +.005 \\ -.000 \end{matrix}$

ORDER EXAMPLE:

(Reference page 4)

SPECIFY: QTY: TYPE "L" DIMENSION "P" ALTERNATE TOLERANCE
 EXAMPLE: 6 MSV 10 30 9.0 STD

Note: When ordering, standard quantity breaks are:
 1, 2-3, 4-11, 12-23, 24-49, 50-99

SHOULDER PUNCH BLANKS



SOLID/EJECTOR

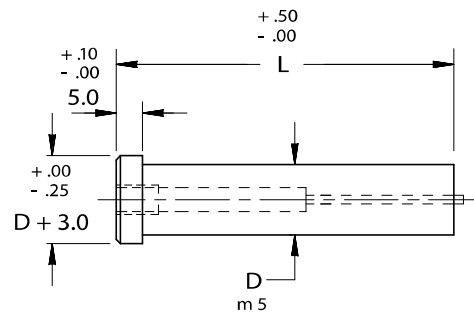
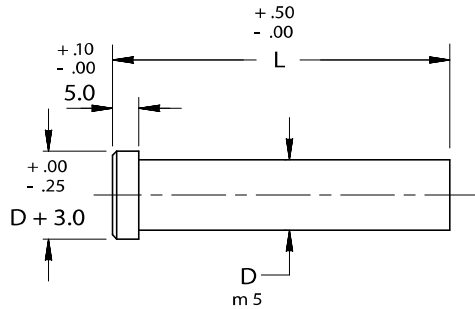

FOR PRODUCT ALTERATIONS SEE PAGES 74-80.

Complete design & CAD files visit WWW.MOELLERMCAD.COM

CATALOG NUMBER SOLID	SHANK DIA D	OVERALL LENGTH "L"																
		40	50	56	60	63	70	71	80	90	100	120	125	150	155	160	165	170
MSB 04	4	X	X	X	X	X	X	X	X	X	X	X						
MSB 05	5	(X)	(X)	(X)	(X)	(X)	(X)	(X)	(X)	(X)	(X)	X	X					
MSB 06	6		(X)	(X)	(X)	(X)	(X)	(X)	(X)	(X)	(X)	X	X					
MSB 08	8		(X)	(X)	(X)	(X)	(X)	(X)	(X)	(X)	(X)	X	X					
MSB 10	10		(X)	(X)	(X)	(X)	(X)	(X)	(X)	(X)	(X)	X	X	X				
MSB 13	13		(X)	(X)	(X)	(X)	(X)	(X)	(X)	(X)	(X)	X	X	X				
MSB 16	16		(X)	(X)	(X)	(X)	(X)	(X)	(X)	(X)	(X)	X	X	X	X			
MSB 20	20			(X)	(X)	(X)	(X)	(X)	(X)	(X)	(X)	X	X	X		X		
MSB 25	25			(X)	(X)	(X)	(X)	(X)	(X)	(X)	(X)	X	X	X			X	
MSB 32	32					(X)	(X)	(X)	(X)	(X)	(X)	X	X	X				X
MSB 40	40								(X)	(X)	(X)		X	X				

Material
 Steel: M2, HRC 60-63 X
 Alternate Available PM4, HRC 60-63 (X)
 Heads HRC 45-55

(X) Must Specify M2 or PM4 when ordering

ORDER EXAMPLE:
 (Reference page 4)
 SPECIFY: QTY: TYPE "D" "L" MATERIAL
 EXAMPLE: 6 MSB 8 100 PM4
 EXAMPLE: 6 MCB 16 125 M2

CATALOG NUMBER EJECTOR	SHANK DIA D	OVERALL LENGTH "L"										
		50	56	60	63	70	71	80	90	100	110	125
MCB 05	5	(X)	(X)	(X)	(X)	(X)	(X)	(X)	(X)	(X)		
MCB 06	6	(X)	(X)	(X)	(X)	(X)	(X)	(X)	(X)	(X)		
MCB 08	8	(X)	(X)	(X)	(X)	(X)	(X)	(X)	(X)	(X)		
MCB 10	10	(X)	(X)	(X)	(X)	(X)	(X)	(X)	(X)	(X)	X	X
MCB 13	13	(X)	(X)	(X)	(X)	(X)	(X)	(X)	(X)	(X)	X	X
MCB 16	16	(X)	(X)	(X)	(X)	(X)	(X)	(X)	(X)	(X)	X	X
MCB 20	20		(X)	(X)	(X)	(X)	(X)	(X)	(X)	(X)	X	X
MCB 25	25		(X)	(X)	(X)	(X)	(X)	(X)	(X)	(X)	X	X
MCB 32	32				(X)	(X)	(X)	(X)	(X)	(X)	X	X
MCB 40	40								(X)	(X)	X	X

SHOULDER PUNCHES

SOLID/WITH CENTER DOWEL

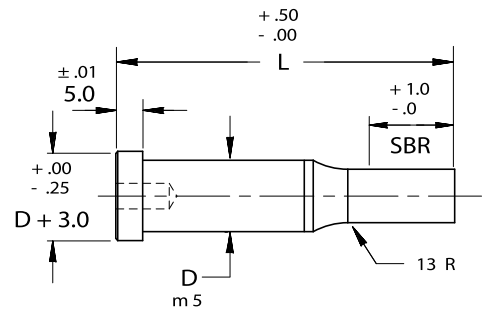
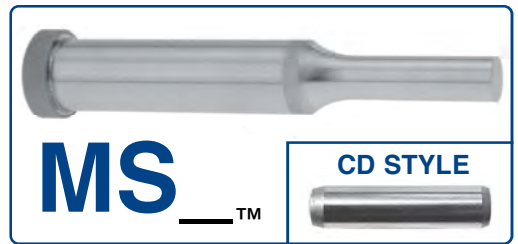
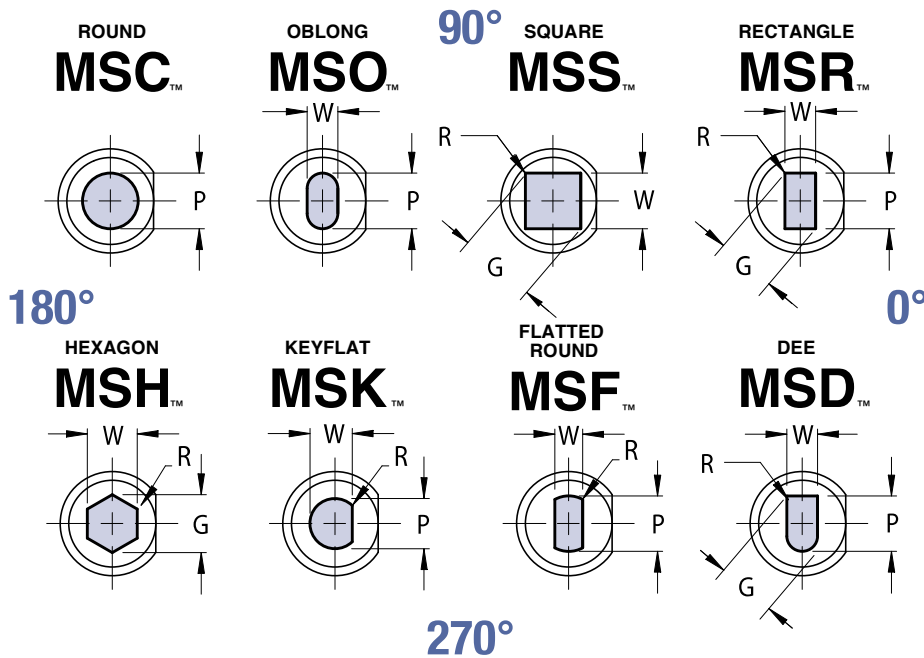

VIEWS ARE SHOWN LOOKING THROUGH THE SHANK BUT DRAWN WITH SOLID LINES FOR CLARITY.

FOR PRODUCT ALTERATIONS SEE PAGES 74-80.

NOTE: MUST SPECIFY CD AND X4=5.0 ALTERATION

Complete design & CAD files visit WWW.MOELLERMCAD.COM

CATALOG TYPE	SHANK DIA D	ROUND	SHAPE		OVERALL LENGTH "L"								
		RANGE P	MIN W	MAX G/P	70	71	80	90	100	110	120	125	150
MS_10	10	3.20 - 9.99	3.20	10.00	(X)	(X)	(X)	(X)	(X)	X	X	X	X
MS_13	13	5.00 - 12.99	4.50	13.00	(X)	(X)	(X)	(X)	(X)	X	X	X	X
MS_16	16	8.00 - 15.99	6.00	16.00	(X)	(X)	(X)	(X)	(X)	X	X	X	X
MS_20	20	10.00 - 19.99	8.00	20.00	(X)	(X)	(X)	(X)	(X)	X	X	X	X
MS_25	25	12.00 - 24.99	9.00	25.00	(X)	(X)	(X)	(X)	(X)	X	X	X	X
MS_32	32	16.00 - 31.99	10.00	32.00	(X)	(X)	(X)	(X)	(X)	X	X	X	X
MS_40	40	30.00 - 39.99	14.00	40.00			(X)	(X)	(X)	X		X	X

Material

Steel: M2, HRC 60-63 X
 Alternate Available PM4, HRC 60-63 (X)
 Heads HRC 45-55

Standard Point Tolerance

Round P $\pm .01$ P to D
 Shape P, W $\pm .01$ P to D

When P = D Shank Tolerances apply

Alternate Point Tolerance

T2

P, W TOLERANCE $\pm .005$ P to D
 $\pm .000$

CATALOG TYPE	SHANK D	SBR		
		STD	B	C
MS_10	10	19	13	25
MS_13	13	19	13	25
MS_16	16	19	13	25
MS_20	20	19	13	25
MS_25	25	19	13	25
MS_32	32	25	19	30
MS_40	40	25	19	30

L=50 SBR MAX=13 L=60 SBR MAX=19
 L=56 SBR MAX=19 L=63 SBR MAX=25

ORDER EXAMPLE:

(Reference page 4)

SPECIFY:	QTY:	TYPE	"D"	"L"	POINT LENGTH	P(OR P&W) DIMENSIONS	ALTERATION CODE	ALTERNATE POINT TOLERANCE	MATERIAL
EXAMPLE:	6	MSC	13	90	13	10.0	CD X4=5.0	T2	M2
EXAMPLE:	6	MSO	16	80	STD	14.0 x 8.0	CD X4=5.0	STD	PM4

Note: When ordering, standard quantity breaks are: 1, 2-3, 4-11, 12-23, 24-49, 50-99

STANDARD FLAT LOCATION IS AT 0° AS SHOWN.
 AVAILABLE AT 90°, 180°, 270°, FOR SAME ALTERATION PRICE.

SHOULDER PUNCHES

EJECTOR/WITH CENTER DOWEL

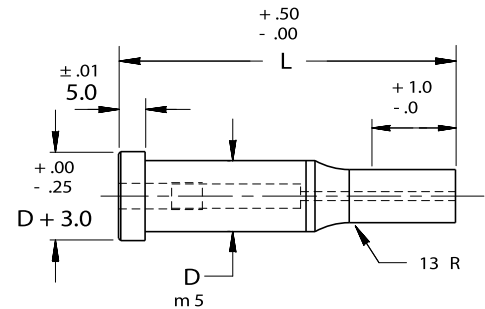
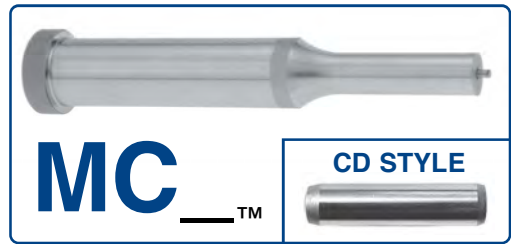
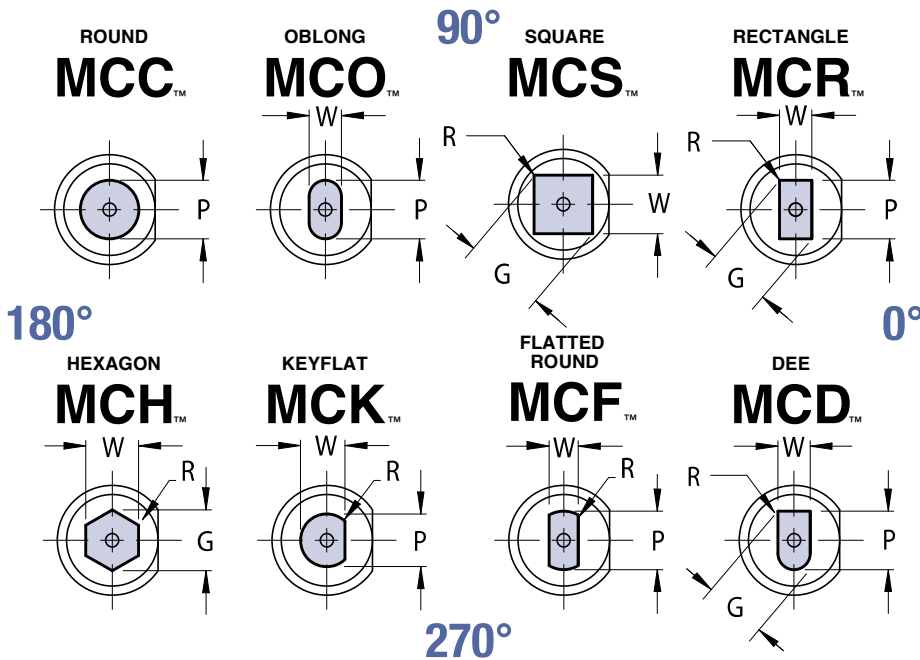

VIEWS ARE SHOWN LOOKING THROUGH THE SHANK BUT DRAWN WITH SOLID LINES FOR CLARITY.

FOR PRODUCT ALTERATIONS SEE PAGES 74-80.

NOTE: MUST SPECIFY CD AND X4=5.0 ALTERATION

Complete design & CAD files visit WWW.MOELLERMCAD.COM

CATALOG TYPE	SHANK DIA D	ROUND	SHAPE		OVERALL LENGTH "L"						
		RANGE P	MIN W	MAX G/P	70	71	80	90	100	110	125
MC_10	10	4.50 - 9.99	4.50	10.00	(X)	(X)	(X)	(X)	(X)	X	X
MC_13	13	6.00 - 12.99	6.00	13.00	(X)	(X)	(X)	(X)	(X)	X	X
MC_16	16	8.00 - 15.99	7.50	16.00	(X)	(X)	(X)	(X)	(X)	X	X
MC_20	20	10.00 - 19.99	8.00	20.00	(X)	(X)	(X)	(X)	(X)	X	X
MC_25	25	12.00 - 24.99	9.00	25.00	(X)	(X)	(X)	(X)	(X)	X	X
MC_32	32	16.00 - 31.99	10.00	32.00	(X)	(X)	(X)	(X)	(X)	X	X
MC_40	40	30.00 - 39.99	14.00	40.00			(X)	(X)	(X)	X	X

Material
 Steel: M2, HRC 60-63 X
 Alternate Available PM4, HRC 60-63 (X)
 Heads HRC 45-55

Standard Point Tolerance
 Round P $\pm .01$ $\begin{matrix} \text{P to D} \\ \text{P to D} \end{matrix}$
 Shape P, W $\pm .01$ $\begin{matrix} \text{P to D} \\ \text{P to D} \end{matrix}$

When P = D Shank Tolerances apply

(X) Must Specify M2 or PM4 when ordering

Alternate Point Tolerance T2

P, W TOLERANCE $\begin{matrix} +.005 \\ -.000 \end{matrix}$
 P to D $\begin{matrix} .008 \\ \text{P to D} \end{matrix}$

CATALOG TYPE	SHANK D	SBR			EJECTOR SIZE
		ALTERNATES			
		STD	B	C	
MC_10	10	19	13	25	MAE 5
MC_13	13	19	13	25	MAE 5
MC_16	16	19	13	25	MAE 6
MC_20	20	19	13	25	MAE 6
MC_25	25	19	13	25	MAE 6
MC_32	32	25	19	30	MAE 6
MC_40	40	25	19	30	MAE 6

L=70 SBR MAX=19
 L=71 SBR MAX=19

ORDER EXAMPLE:

(Reference page 4)

SPECIFY:	QTY:	TYPE	"D"	"L"	POINT LENGTH	P(OR P&W) DIMENSIONS	ALTERATION CODE	ALTERNATE POINT TOLERANCE	MATERIAL
EXAMPLE: 6	MCC	13	90	STD	10.0	CD X4=5.0	STD	M2	
EXAMPLE: 6	MCO	16	80	B	13.0 x 9.0	CD X4=5.0	T2	PM4	

Note: When ordering, standard quantity breaks are: 1, 2-3, 4-11, 12-23, 24-49, 50-99

STANDARD FLAT LOCATION IS AT 0° AS SHOWN.
 AVAILABLE AT 90°, 180°, 270°, FOR SAME ALTERATION PRICE.

SHOULDER PILOTS

PILOT/WITH CENTER DOWEL

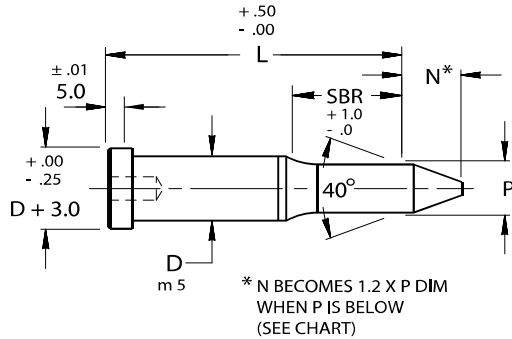

LONG LEAD STYLE



FOR PRODUCT ALTERATIONS SEE PAGES 74-80.

ORDER EXAMPLE:

(Reference page 4)

SPECIFY:	QTY:	TYPE	"D"	"L"	POINT LENGTH	"P" DIMENSION	ALTERATION CODE	ALTERNATE TOLERANCE	MATERIAL
EXAMPLE: 6	MSA	20	90	STD	17.0	CD X4=5.0	STD	M2	
EXAMPLE: 6	MSA	20	90	STD	17.0	CD X4=5.0	STD	PM4	

Note: When ordering, standard quantity breaks are: 1, 2-3, 4-11, 12-23, 24-49, 50-99

NOTE: MUST SPECIFY CD AND X4=5.0 ALTERATION

Complete design & CAD files visit WWW.MOELLERMCAD.COM

CATALOG TYPE	SHANK DIA D	RANGE P	LEAD N	P BELOW SEE NOTE*	LENGTH "L"								
					63	70	71	80	90	100	110	125	140
MS_10	10	4.85 - 10.00	8	5.64	X	X	X	X	X	X	X		
MS_13	13	6.30 - 13.00	10	7.11	X	X	X	X	X	X	X	X	X
MS_16	16	9.95 - 16.00	15	10.74		X	X	X	X	X	X	X	X
MS_20	20	13.60 - 20.00	20	14.38		X	X	X	X	X	X	X	X
MS_25	25	17.25 - 25.00	25	18.00		X	X	X	X	X	X	X	X
MS_32	32	20.85 - 32.00	30	21.67			X	X	X	X	X	X	X

Material
 Steel: M2, HRC 60-63
 Alternate Available PM4, HRC 60-63
 Heads HRC 45-55

Standard Point Tolerance
 Round P $\pm .01$ $\pm .01$ P to D
 Shape P, W $\pm .01$ $\pm .02$ P to D
 When P = D Shank Tolerances apply

Must Specify M2 or PM4 when ordering

CATALOG TYPE	SHANK D	SBR	
		STD	ALTERNATES B
MS_10	10	19	25
MS_13	13	19	25
MS_16	16	19	25
MS_20	20	19	25
MS_25	25	19	25
MS_32	32	25	30

Alternate Point Tolerance **T2**
 P, W TOLERANCE $\pm .005$ / $\pm .000$
 P to D $\pm .008$

REDUCED SHANK PUNCHES



SOLID/EJECTOR

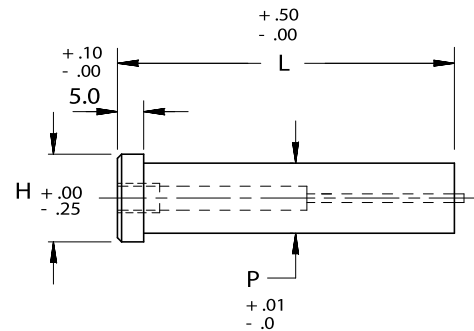
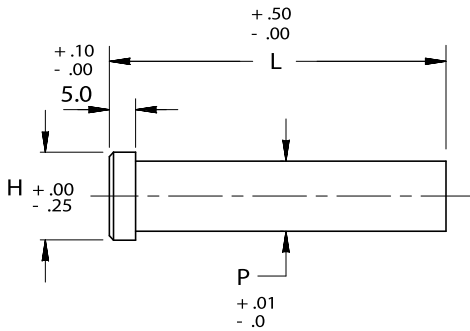

Material
 Steel: M2, HRC 60-63
 Alternate Available PM4, HRC 60-63
 Heads HRC 45-55

Must Specify M2 or PM4 when ordering

ORDER EXAMPLE:
 (Reference page 4)

SPECIFY:	QTY:	TYPE	"L"	DIMENSION	MATERIAL
EXAMPLE: 6	MSX 10	80	8.50	PM4	
EXAMPLE: 6	MCX 16	70	14.0	M2	

Note: When ordering, standard quantity breaks are:
 1, 2-3, 4-11, 12-23, 24-49, 50-99

Complete design & CAD files visit WWW.MOELLERMCAD.COM

FOR PRODUCT ALTERATIONS SEE PAGES 74-80.

CATALOG TYPE SOLID	SHANK DIA D RANGE	HEAD DIA H	OVERALL LENGTH "L"											
			50	56	60	63	70	71	80	90	100	120	125	
MSX 04	3.01 - 4.00	7	X	X	X	X	X	X	X	X	X	X	X	X
MSX 05	4.01 - 5.00	8	<input checked="" type="checkbox"/>	<input checked="" type="checkbox"/>	<input checked="" type="checkbox"/>	<input checked="" type="checkbox"/>	<input checked="" type="checkbox"/>	<input checked="" type="checkbox"/>	<input checked="" type="checkbox"/>	<input checked="" type="checkbox"/>	<input checked="" type="checkbox"/>	<input checked="" type="checkbox"/>	X	X
MSX 06	5.01 - 6.00	9	<input checked="" type="checkbox"/>	<input checked="" type="checkbox"/>	<input checked="" type="checkbox"/>	<input checked="" type="checkbox"/>	<input checked="" type="checkbox"/>	<input checked="" type="checkbox"/>	<input checked="" type="checkbox"/>	<input checked="" type="checkbox"/>	<input checked="" type="checkbox"/>	<input checked="" type="checkbox"/>	X	X
MSX 08	6.01 - 8.00	11	<input checked="" type="checkbox"/>	<input checked="" type="checkbox"/>	<input checked="" type="checkbox"/>	<input checked="" type="checkbox"/>	<input checked="" type="checkbox"/>	<input checked="" type="checkbox"/>	<input checked="" type="checkbox"/>	<input checked="" type="checkbox"/>	<input checked="" type="checkbox"/>	<input checked="" type="checkbox"/>	X	X
MSX 10	8.01 - 10.00	13	<input checked="" type="checkbox"/>	<input checked="" type="checkbox"/>	<input checked="" type="checkbox"/>	<input checked="" type="checkbox"/>	<input checked="" type="checkbox"/>	<input checked="" type="checkbox"/>	<input checked="" type="checkbox"/>	<input checked="" type="checkbox"/>	<input checked="" type="checkbox"/>	<input checked="" type="checkbox"/>	X	X
MSX 13	10.01 - 13.00	16	<input checked="" type="checkbox"/>	<input checked="" type="checkbox"/>	<input checked="" type="checkbox"/>	<input checked="" type="checkbox"/>	<input checked="" type="checkbox"/>	<input checked="" type="checkbox"/>	<input checked="" type="checkbox"/>	<input checked="" type="checkbox"/>	<input checked="" type="checkbox"/>	<input checked="" type="checkbox"/>	X	X
MSX 16	13.01 - 16.00	19	<input checked="" type="checkbox"/>	<input checked="" type="checkbox"/>	<input checked="" type="checkbox"/>	<input checked="" type="checkbox"/>	<input checked="" type="checkbox"/>	<input checked="" type="checkbox"/>	<input checked="" type="checkbox"/>	<input checked="" type="checkbox"/>	<input checked="" type="checkbox"/>	<input checked="" type="checkbox"/>	X	X

CATALOG TYPE EJECTOR	SHANK DIA D RANGE	HEAD DIA H	OVERALL LENGTH "L"								EJECTOR SIZE	
			50	56	60	63	70	71	80	90		100
MCX 05	4.01 - 5.00	8	<input checked="" type="checkbox"/>	<input checked="" type="checkbox"/>	<input checked="" type="checkbox"/>	<input checked="" type="checkbox"/>	<input checked="" type="checkbox"/>	<input checked="" type="checkbox"/>	<input checked="" type="checkbox"/>	<input checked="" type="checkbox"/>	<input checked="" type="checkbox"/>	MAE 2
MCX 06	5.01 - 6.00	9	<input checked="" type="checkbox"/>	<input checked="" type="checkbox"/>	<input checked="" type="checkbox"/>	<input checked="" type="checkbox"/>	<input checked="" type="checkbox"/>	<input checked="" type="checkbox"/>	<input checked="" type="checkbox"/>	<input checked="" type="checkbox"/>	<input checked="" type="checkbox"/>	MAE 3
MCX 08	6.01 - 8.00	11	<input checked="" type="checkbox"/>	<input checked="" type="checkbox"/>	<input checked="" type="checkbox"/>	<input checked="" type="checkbox"/>	<input checked="" type="checkbox"/>	<input checked="" type="checkbox"/>	<input checked="" type="checkbox"/>	<input checked="" type="checkbox"/>	<input checked="" type="checkbox"/>	MAE 4
MCX 10	8.01 - 10.00	13	<input checked="" type="checkbox"/>	<input checked="" type="checkbox"/>	<input checked="" type="checkbox"/>	<input checked="" type="checkbox"/>	<input checked="" type="checkbox"/>	<input checked="" type="checkbox"/>	<input checked="" type="checkbox"/>	<input checked="" type="checkbox"/>	<input checked="" type="checkbox"/>	MAE 5
MCX 13	10.01 - 13.00	16	<input checked="" type="checkbox"/>	<input checked="" type="checkbox"/>	<input checked="" type="checkbox"/>	<input checked="" type="checkbox"/>	<input checked="" type="checkbox"/>	<input checked="" type="checkbox"/>	<input checked="" type="checkbox"/>	<input checked="" type="checkbox"/>	<input checked="" type="checkbox"/>	MAE 5
MCX 16	13.01 - 16.00	19	<input checked="" type="checkbox"/>	<input checked="" type="checkbox"/>	<input checked="" type="checkbox"/>	<input checked="" type="checkbox"/>	<input checked="" type="checkbox"/>	<input checked="" type="checkbox"/>	<input checked="" type="checkbox"/>	<input checked="" type="checkbox"/>	<input checked="" type="checkbox"/>	MAE 6

QUILL PUNCHES

SQUARE HEAD

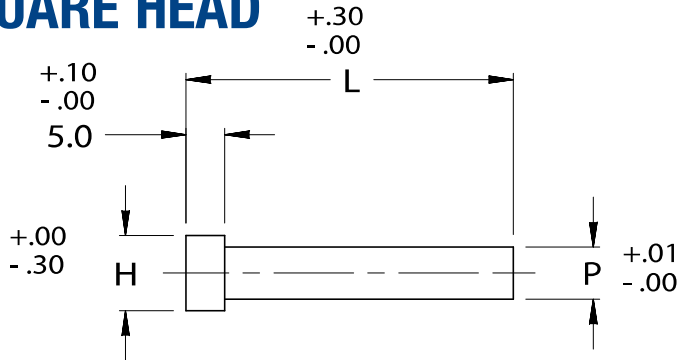

MQS™

Material

Steel: M2, HRC 60-63

Complete design & CAD files visit WWW.MOELLERMCAD.COM

CATALOG NUMBER	RANGE P	HEAD DIA. H	OVERALL LENGTH "L"				
			STD. LENGTHS		OPTIONAL LENGTHS		
			50	63	40	45	56
MQS 01	.80 - 1.60	3	X	X	X	X	X
MQS 02	1.61 - 2.00	4	X	X	X	X	X
MQS 03	2.01 - 3.00	5	X	X	X	X	X
MQS 04	3.01 - 4.00	6	X	X	X	X	X
MQS 05	4.01 - 5.00	7	X	X	X	X	X
MQS 06	5.01 - 6.00	8	X	X	X	X	X
MQS 07	6.01 - 7.00	9	X	X	X	X	X

"P" Dimension must be ordered in .01 increments. Other three place sizes are P.O.R.

FOR PRODUCT ALTERATIONS SEE PAGES 74-80.

BEVEL HEAD

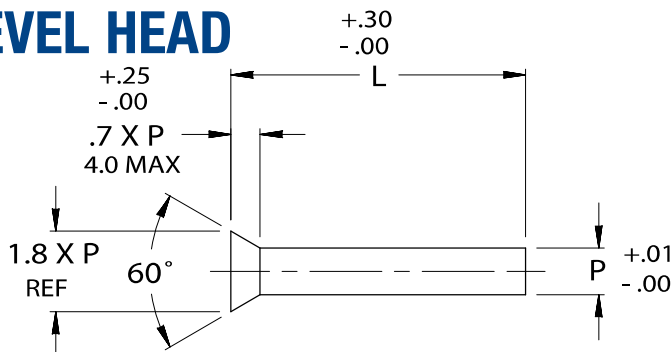

MQB™

Material

Steel: M2, HRC 60-63

Complete design & CAD files visit WWW.MOELLERMCAD.COM

CATALOG TYPE	RANGE P	OVERALL LENGTH "L"				
		STD. LENGTHS		OPTIONAL LENGTHS		
		50	63	40	45	56
MQB 01	.80 - 1.60	X	X	X	X	X
MQB 02	1.61 - 2.00	X	X	X	X	X
MQB 03	2.01 - 3.00	X	X	X	X	X
MQB 04	3.01 - 4.00	X	X	X	X	X
MQB 05	4.01 - 5.00	X	X	X	X	X
MQB 06	5.01 - 6.00	X	X	X	X	X
MQB 07	6.01 - 7.00	X	X	X	X	X

*"P" Dimension must be ordered in .01 increments. Other three place sizes are P.O.R.

*All metric quill punches are P.O.R.

ORDER EXAMPLE:

(Reference page 4)

SPECIFY:	QTY:	TYPE	"D"	"L"	"P" DIMENSION
EXAMPLE:	6	MQS	04	40	3.50
EXAMPLE:	6	MQB	05	50	4.50

Note: When ordering, standard quantity breaks are: 1, 2-3, 4-11, 12-23, 24-49, 50-99

FOR PRODUCT ALTERATIONS SEE PAGES 74-80.

SOLID

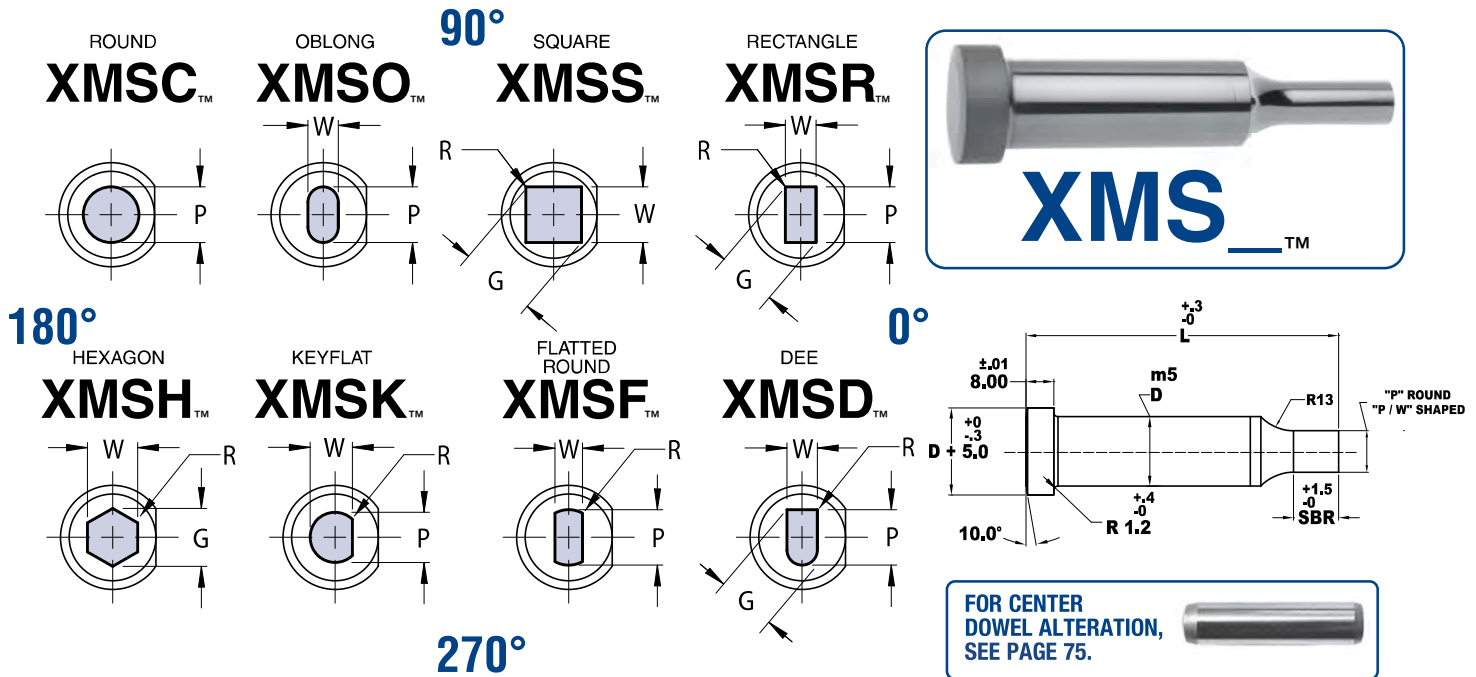



VIEWS ARE SHOWN LOOKING THROUGH THE SHANK BUT DRAWN WITH SOLID LINES FOR CLARITY. FOR PRODUCT ALTERATIONS SEE PAGES 74-80.

SHANK CATALOG TYPE	ROUND DIA D	ROUND	SHAPE		OVERALL LENGTH "L"						
		RANGE P	MIN W	MAX G/P	70	80	90	100	110	125	150
XMS_08	08	3.10 - 7.99	3.10	8.00	X	X	X	X	X	X	X
XMS_10	10	3.20 - 9.99	3.20	10.00	X	X	X	X	X	X	X
XMS_13	13	5.00 - 12.99	4.50	13.00	X	X	X	X	X	X	X
XMS_16	16	8.00 - 15.99	6.00	16.00	X	X	X	X	X	X	X
XMS_20	20	10.00 - 19.99	8.00	20.00	X	X	X	X	X	X	X
XMS_25	25	12.00 - 24.99	9.00	25.00	X	X	X	X	X	X	X
XMS_32	32	16.00 - 31.99	10.00	32.00	X	X	X	X	X	X	X

Material
 Steel: PM4 HRC 60-62
 Heads HRC 40-55

Standard Point Tolerance

Round P $\begin{matrix} +.01 \\ -.00 \end{matrix}$  .01 P to D

Shape P, W $\pm .01$  .025 P to D

CATALOG TYPE	SHANK D	POINT LENGTH "SBR"	
		STD	ALTERNATE B
XMS_08	10	13	19
XMS_10	10	13	19
XMS_13	13	13	19
XMS_16	16	19	25
XMS_20	20	19	25
XMS_25	25	19	25
XMS_32	32	19	25

ORDER EXAMPLE:
 (Reference page 4)

SPECIFY:	QTY:	TYPE	"D"	"L"	POINT LENGTH	P(OR P&W) DIMENSIONS	ALTERATION CODE
EXAMPLE:	6	XMSC	13	90	13	10.0	CD
EXAMPLE:	6	XMSO	16	80	STD	14.0 x 8.0	F1 @ 90

Note: When ordering, standard quantity breaks are: 1, 2-3, 4-11, 12-23, 24-49, 50-99

STANDARD FLAT LOCATION IS AT 0° AS SHOWN.
 AVAILABLE AT 90°, 180°, 270°, FOR SAME ALTERATION PRICE.

EJECTOR

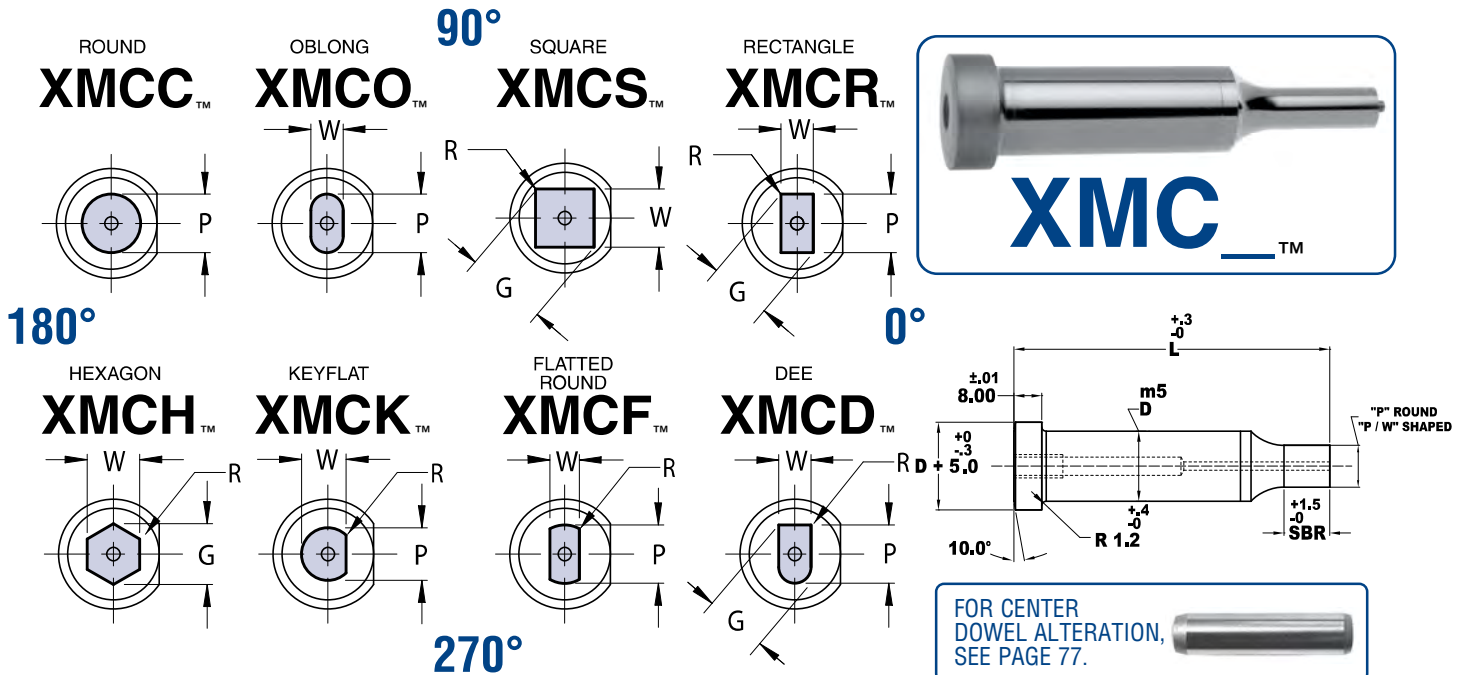

VIEWS ARE SHOWN LOOKING THROUGH THE SHANK BUT DRAWN WITH SOLID LINES FOR CLARITY.

FOR OTHER STANDARD ALTERATIONS, SEE PAGES 74-80.

SHANK CATALOG TYPE	ROUND DIA D	ROUND	SHAPE		OVERALL LENGTH "L"					
		RANGE P	MIN W	MAX G/P	70	80	90	100	110	125
XMC_08	08	4.00 - 7.99	4.00	8.00	X	X	X	X	X	X
XMC_10	10	4.50 - 9.99	4.50	10.00	X	X	X	X	X	X
XMC_13	13	6.00 - 12.99	6.00	13.00	X	X	X	X	X	X
XMC_16	16	8.00 - 15.99	7.50	16.00	X	X	X	X	X	X
XMC_20	20	10.00 - 19.99	8.00	20.00	X	X	X	X	X	X
XMC_25	25	12.00 - 24.99	9.00	25.00	X	X	X	X	X	X
XMC_32	32	16.00 - 31.99	10.00	32.00	X	X	X	X	X	X

Material

Steel: PM4 HRC 60-62
Heads HRC 40-55

Standard Point Tolerance

Round P $\begin{matrix} +.01 \\ -.00 \end{matrix}$  .01 P to D
Shape P, W $\pm .01$  .025 P to D

ORDER EXAMPLE:

(Reference page 4)

SPECIFY:	QTY:	TYPE	"D"	"L"	POINT LENGTH	P(OR P&W) DIMENSIONS	ALTERATION CODE
EXAMPLE:	6	XMCC	13	90	13	10.0	CD
EXAMPLE:	6	XMCO	16	80	STD	14.0 x 8.0	F1 @ 90

Note: When ordering, standard quantity breaks are: 1, 2-3, 4-11, 12-23, 24-49, 50-99

CATALOG TYPE	SHANK D	POINT LENGTH "SBR"		EJECTOR SIZE
		STD	ALTERNATE B	
XMC_08	10	13	19	MAE 4
XMC_10	10	13	19	MAE 5
XMC_13	13	13	19	MAE 5
XMC_16	16	19	25	MAE 6
XMC_20	20	19	25	MAE 6
XMC_25	25	19	25	MAE 6
XMC_32	32	19	25	MAE 6

STANDARD FLAT LOCATION IS AT 0° AS SHOWN.
AVAILABLE AT 90°, 180°, 270°, FOR SAME ALTERATION PRICE.

SOLID/EJECTOR

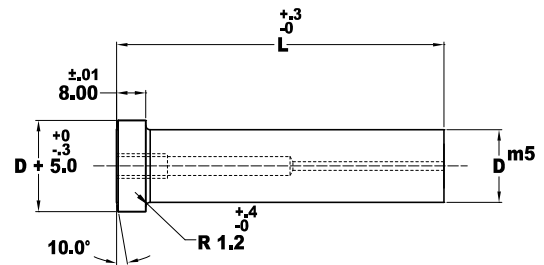
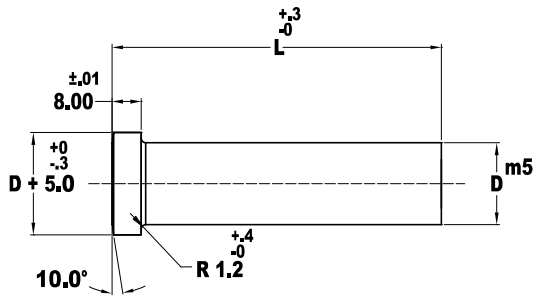
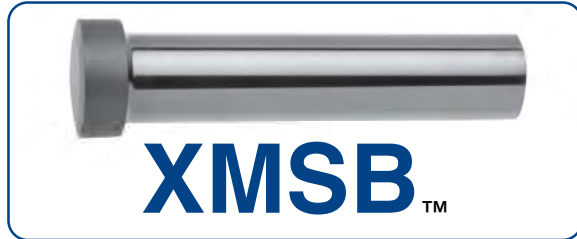

Material
 Steel: PM4 HRC 60-62
 Heads HRC 40-55

FOR STANDARD ALTERATIONS SEE
 PAGES 74-80.

CATALOG NUMBER SOLID	SHANK DIA D	OVERALL LENGTH "L"						
		70	80	90	100	110	125	150
XMSB 08	08	X	X	X	X	X	X	X
XMSB 10	10	X	X	X	X	X	X	X
XMSB 13	13	X	X	X	X	X	X	X
XMSB 16	16	X	X	X	X	X	X	X
XMSB 20	20	X	X	X	X	X	X	X
XMSB 25	25	X	X	X	X	X	X	X
XMSB 32	32	X	X	X	X	X	X	X

ORDER EXAMPLE:
 (Reference page 4)
 SPECIFY: QTY: TYPE "D" "L"
 EXAMPLE: 6 XMSB 8 100
 EXAMPLE: 6 XMCB 16 90
 Note: When ordering, standard quantity breaks are:
 1, 2-3, 4-11, 12-23, 24-49, 50-99

CATALOG NUMBER EJECTOR	SHANK DIA D	OVERALL LENGTH "L"							EJECTOR SIZE
		70	80	90	100	110	125		
XMCB 08	08	X	X	X	X	X	X	MAE 4	
XMCB 10	10	X	X	X	X	X	X	MAE 5	
XMCB 13	13	X	X	X	X	X	X	MAE 5	
XMCB 16	16	X	X	X	X	X	X	MAE 6	
XMCB 20	20	X	X	X	X	X	X	MAE 6	
XMCB 25	25	X	X	X	X	X	X	MAE 6	
XMCB 32	32	X	X	X	X	X	X	MAE 6	

SOLID

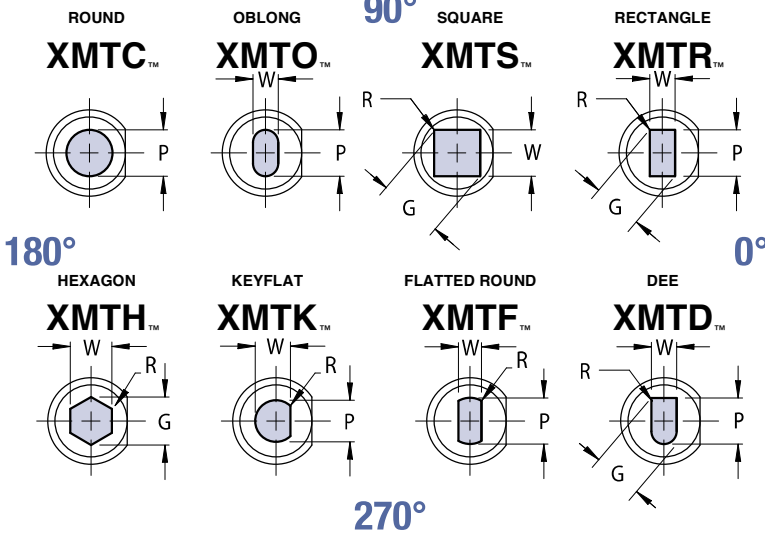

ORDER EXAMPLE:
 (Reference page 4)

SPECIFY:	QTY:	TYPE	"D"	"L"	POINT LENGTH	P (OR P&W) DIMENSIONS	ALTERATION CODE
EXAMPLE:	6	XMTC	013	090	13	10.0	F1
EXAMPLE:	6	XMTO	016	080	STD	14.0 x 8.0	F1 @ 90

Note: When ordering, standard quantity breaks are: 1, 2-3, 4-11, 12-23, 24-49, 50-99

FOR STANDARD ALTERATIONS SEE PAGES 74-80

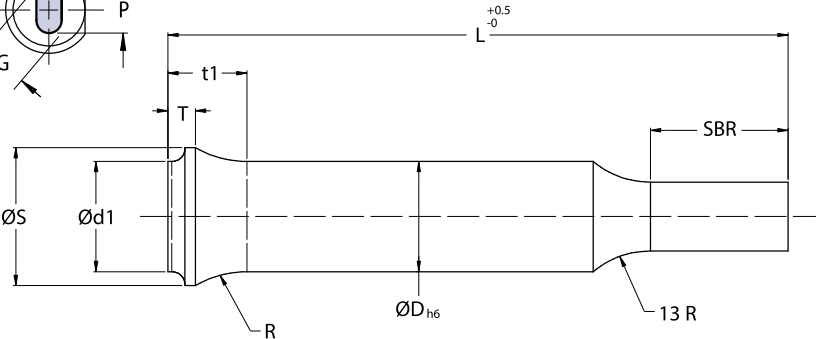

VIEWS ARE SHOWN LOOKING THROUGH THE SHANK BUT DRAWN WITH SOLID LINES FOR CLARITY.

CATALOG TYPE	ØD	ØS	Ød1	t1	T	R	ROUND	SHAPE		OVERALL LENGTH "L"			
							RANGE P	MIN. W	MAX P/G	71	80	90	100
XMT_005	5	7	5	8.36	4	10	1.60-4.99	1.60	5.00	X	X	X	X
XMT_006	6	9	6	9.27	4	10	1.60-5.99	1.60	6.00	X	X	X	X
XMT_008	8	11	8	9.81	4	12	2.50-7.99	2.50	8.00	X	X	X	X
XMT_010	10	14	10	11.48	4	15	3.20-9.99	3.20	10.00	X	X	X	X
XMT_013	13	17	13	11.48	4	15	5.00-12.99	4.50	13.00	X	X	X	X
XMT_016	16	20	16	11.48	4	15	8.00-15.99	6.00	16.00	X	X	X	X
XMT_020	20	25	20	12.29	4	15	10.00-19.99	8.00	20.00	X	X	X	X

Material
 Steel: PM4 HRC 62-66
 Heads HRC 45-55

Standard Point Tolerance

Round P $\begin{matrix} +.01 \\ -.00 \end{matrix}$ $\text{⊙} \begin{matrix} .01 \\ P \text{ to } D \end{matrix}$

Shape P, W $\pm .01$ $\text{⊙} \begin{matrix} .02 \\ P \text{ to } D \end{matrix}$

Alternate Point Tolerance **T2**

P, W TOLERANCE $\begin{matrix} +.005 \\ -.000 \end{matrix}$
 P to D $\begin{matrix} .008 \\ \text{⊙} \end{matrix}$

STANDARD FLAT LOCATION IS AT 0° AS SHOWN. AVAILABLE AT 90°, 180°, 270°, FOR SAME ALTERATION PRICE.

CATALOG TYPE	SHANK D	SBR		
		STD.	ALTERNATES	
			B	C
XMT_005	5	13	10	-
XMT_006	6	13	10	-
XMT_008	8	19	13	-
XMT_010	10	19	13	25
XMT_013	13	19	13	25
XMT_016	16	19	13	25
XMT_020	20	19	13	25

SOLID

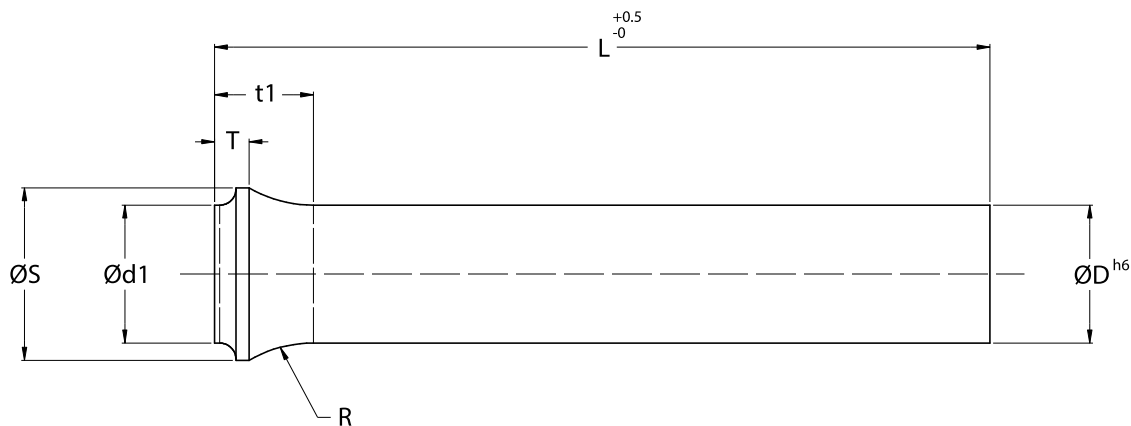
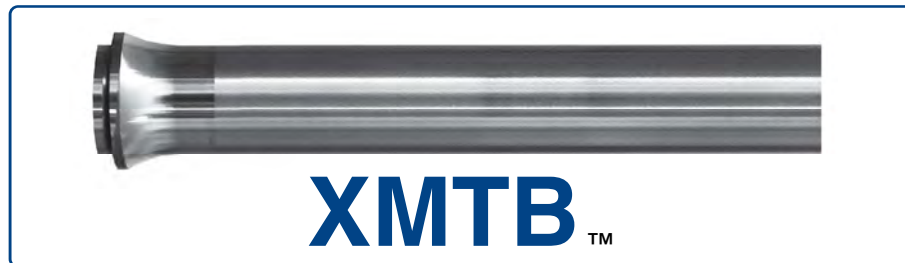

FOR STANDARD ALTERATIONS
SEE PAGES 74-80.

Material
Steel: PM4 HRC 62-66
Heads HRC 45-55

ORDER EXAMPLE:
(Reference page 4)
SPECIFY: QTY: TYPE "D" "L"
EXAMPLE: 6 XMTB 013 080
EXAMPLE: 6 XMTB 016 080
Note: When ordering, standard quantity breaks are: 1, 2-3, 4-11, 12-23, 24-49, 50-99

CATALOG TYPE	SHANK DIA						OVERALL LENGTH "L"			
	ØD	ØS	Ød1	t1	T	R	71	80	90	100
XMTB 005	5	7	5	8.36	4	10	X	X	X	X
XMTB 006	6	9	6	9.27	4	10	X	X	X	X
XMTB 008	8	11	8	9.81	4	12	X	X	X	X
XMTB 010	10	14	10	11.48	4	15	X	X	X	X
XMTB 013	13	17	13	11.48	4	15	X	X	X	X
XMTB 016	16	20	16	11.48	4	15	X	X	X	X
XMTB 020	20	25	20	12.29	4	15	X	X	X	X

PRESS FIT BUTTONS

COUNTER BORE RELIEF

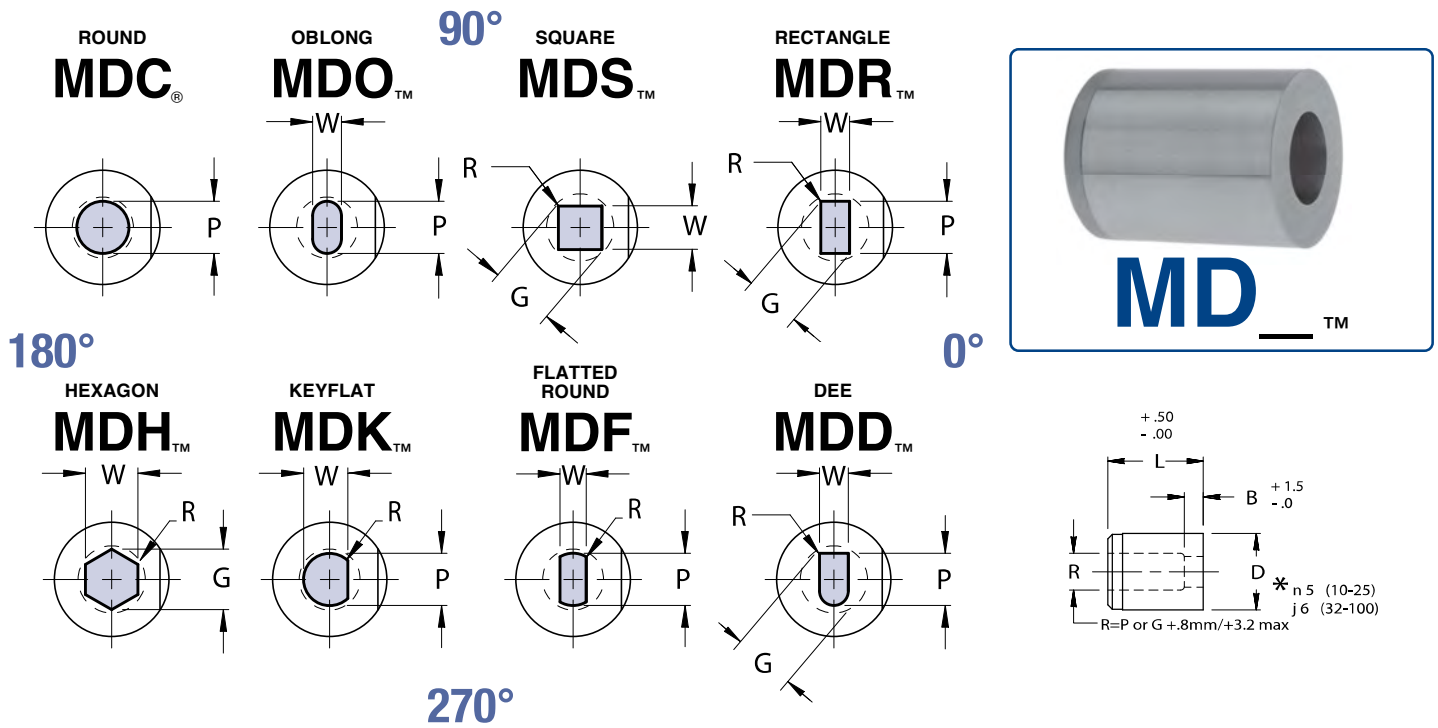

VIEWES ARE SHOWN LOOKING AT TOP FACE OF BUTTON.

Complete design & CAD files visit WWW.MOELLERMCAD.COM

CATALOG TYPE	BODY DIA D	LAND LENGTH "B"			MAX DIA R	SHAPE		OVERALL LENGTH "L"							
		STD	ALT A	ALT B		ROUND RANGE P	MIN W	MAX G/P	20	22	25	28	30	32	35
MD_08	8	4.0	8.0		4.0	1.50 - 3.20	1.50 3.20	(X)	(X)	(X)	(X)	(X)	(X)	(X)	(X)
MD_10	10	4.0	8.0		6.0	1.60 - 5.00	1.60 5.00	(X)	(X)	(X)	(X)	(X)	(X)	(X)	(X)
MD_13	13	5.0	8.0		8.0	1.80 - 7.20	1.80 7.20	(X)	(X)	(X)	(X)	(X)	(X)	(X)	(X)
MD_16	16	5.0	8.0		9.5	5.00 - 8.80	2.50 8.80	(X)	(X)	(X)	(X)	(X)	(X)	(X)	(X)
MD_20	20	5.0	12.0		12.0	5.50 - 11.00	3.20 11.00	(X)	(X)	(X)	(X)	(X)	(X)	(X)	(X)
MD_22	22	6.0	12.0		15.0	7.50 - 14.00	4.00 14.00	(X)	(X)	(X)	(X)	(X)	(X)	(X)	(X)
MD_25	25	6.0	12.0		17.5	9.50 - 16.50	4.80 16.50	(X)	(X)	(X)	(X)	(X)	(X)	(X)	(X)
MD_32	32	6.0	12.0		21.0	13.00 - 20.00	5.50 20.00	(X)	(X)	(X)	(X)	(X)	(X)	(X)	(X)
MD_38	38	8.0	12.0		27.0	16.00 - 26.00	6.40 26.00	(X)	(X)	(X)	(X)	(X)	(X)	(X)	(X)
MD_40	40	8.0	12.0		27.0	16.60 - 26.00	6.40 26.00	(X)	(X)	(X)	(X)	(X)	(X)	(X)	(X)

Material

Steel: A2, HRC 58-60

(X) Alternate M2, HRC 60-63 (Must Specify)

Standard Point Tolerance

Round P $\begin{matrix} +.01 \\ -.00 \end{matrix}$.01 P to D

Shape P, W $\begin{matrix} +.02 \\ -.0 \end{matrix}$.02 P to D

STANDARD FLAT LOCATION IS AT 0° AS SHOWN.

AVAILABLE AT 90°, 180°, 270°, FOR SAME

ALTERATION PRICE.

ORDER EXAMPLE:

(Reference page 4)

SPECIFY:	QTY:	TYPE	"D"	"L"	"B"	P (OR P&W) DIMENSIONS	ALTERATION CODE	STEEL
EXAMPLE:	6	MDC	20	30	A	9.0	F2	A-2
EXAMPLE:	6	MDO	13	20	STD	6.0 x 3.0	F2	M-2

Note: When ordering, standard quantity breaks are: 1, 2-3, 4-11, 12-23, 24-49, 50-99

FOR SLUG CONTROL AND STANDARD ALTERATIONS SEE PAGES 74-80.

PRESS FIT BUTTONS

COUNTER BORE RELIEF/EXTENDED RANGE

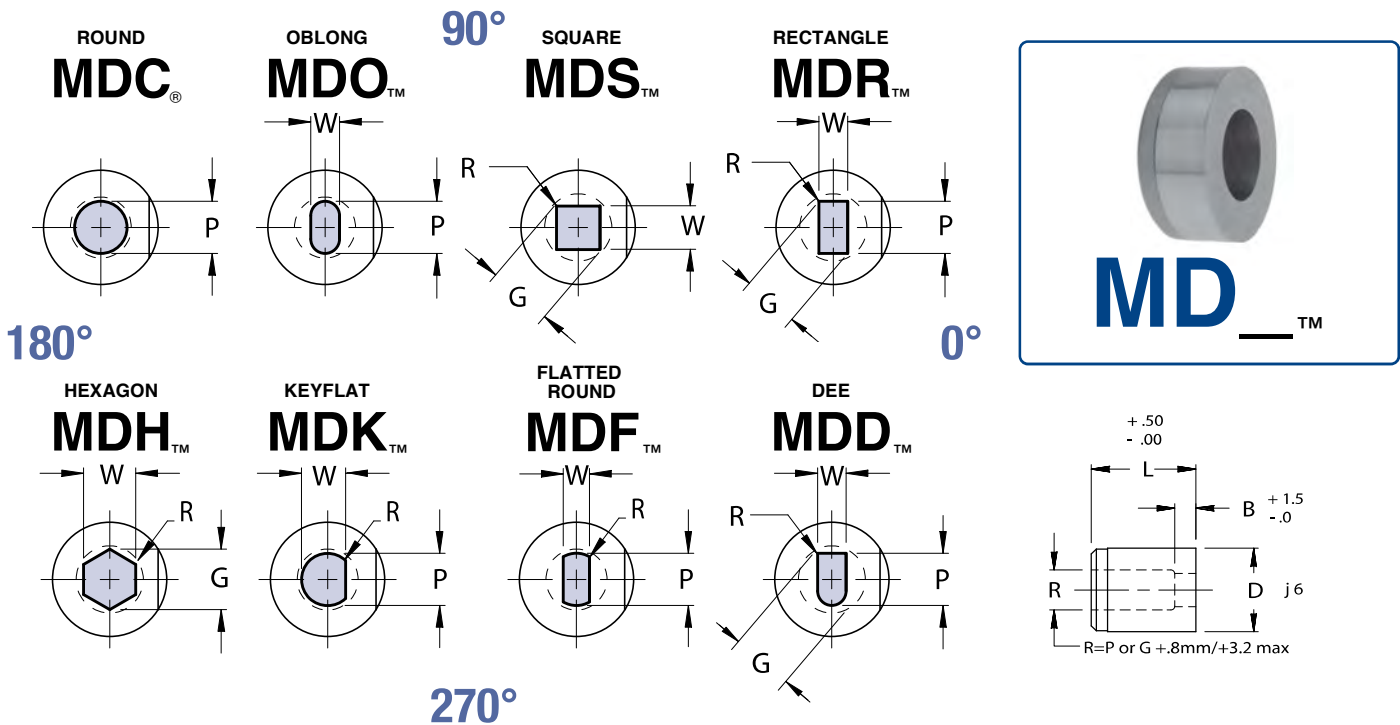

VIEWS ARE SHOWN LOOKING AT TOP FACE OF BUTTON.

Complete design & CAD files visit WWW.MOELLERMCAD.COM

CATALOG TYPE	BODY DIA D	LAND LENGTH "B"			MAX DIA R	ROUND RANGE P	SHAPE		OVERALL LENGTH "L"					
		STD	ALT A	ALT B			MIN W	MAX G/P	22	25	28	30	32	35
MD_45	45	8.0	12.0	20.0	36.0	17.50 - 35.00	7.50	35.00	(X)	(X)	(X)	(X)	(X)	(X)
MD_50	50	8.0	12.0	20.0	41.0	20.00 - 40.00	8.00	40.00	(X)	(X)	(X)	(X)	(X)	(X)
MD_56	56	8.0	12.0	20.0	46.0	22.50 - 45.00	9.00	45.00	(X)	(X)	(X)	(X)	(X)	(X)
MD_63	63	8.0	12.0	20.0	51.0	25.00 - 50.00	10.00	50.00	(X)	(X)	(X)	(X)	(X)	(X)
MD_71	71	8.0	12.0	20.0	57.0	27.50 - 56.00	11.00	56.00	(X)	(X)	(X)	(X)	(X)	(X)

Material
 Steel: A2, HRC 58-60
 (X) Alternate M2, HRC 60-63 (Must Specify)

Standard Point Tolerance

Round P $\begin{matrix} +.01 \\ -.00 \end{matrix}$.01 P to D

Shape P, W $\begin{matrix} +.02 \\ -.0 \end{matrix}$.02 P to D

STANDARD FLAT LOCATION IS AT 0° AS SHOWN.
 AVAILABLE AT 90°, 180°, 270°, FOR SAME ALTERATION PRICE.

ORDER EXAMPLE:
 (Reference page 4)

SPECIFY:	QTY:	TYPE	"D"	"L"	"B"	LAND LENGTH "B"	P(OR P&W) DIMENSIONS	ALTERATION CODE	STEEL
EXAMPLE:	6	MDC	50	30	A	35.0	F2	A-2	
EXAMPLE:	6	MDO	63	25	STD	42.5 x 18.3	F2	M2	

Note: When ordering, standard quantity breaks are: 1, 2-3, 4-11, 12-23, 24-49, 50-99

FOR SLUG CONTROL AND STANDARD ALTERATIONS SEE PAGES 74-80.

PRESS FIT BUTTONS



ULTRA LIFE/TAPER RELIEF

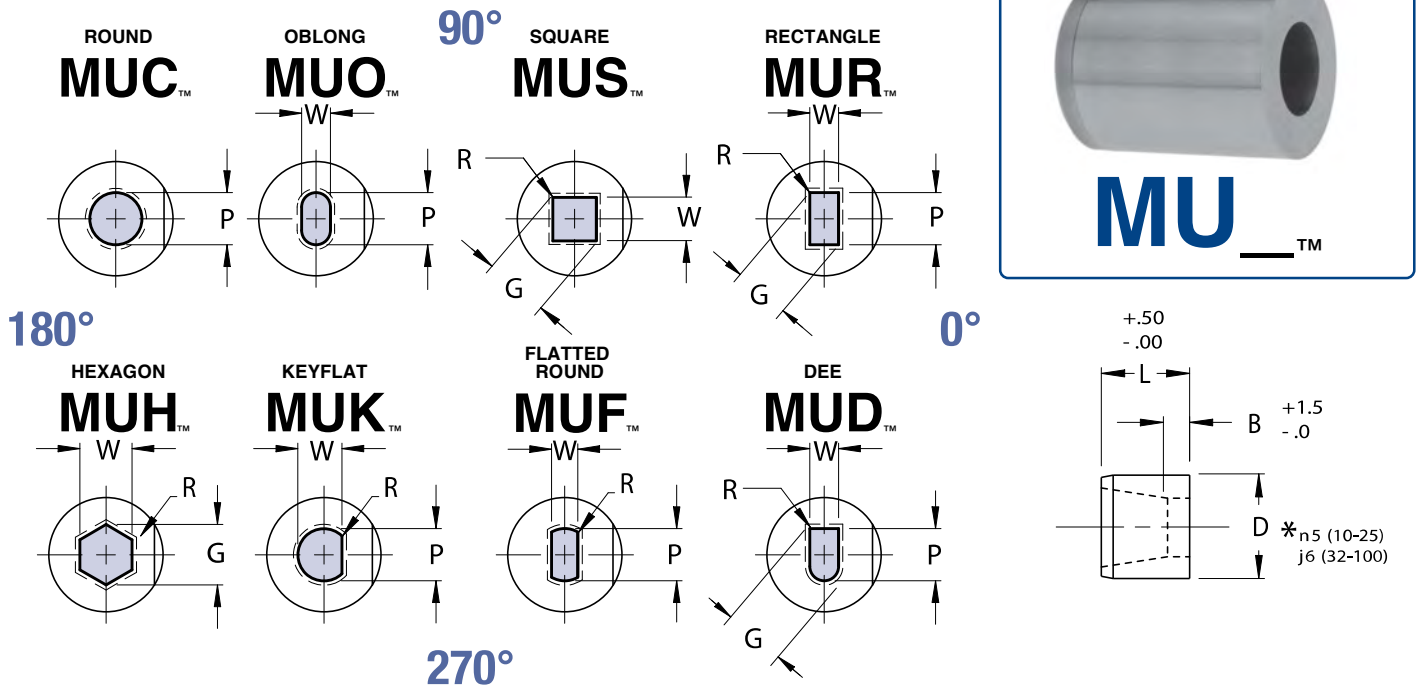

VIEWS ARE SHOWN LOOKING AT TOP FACE OF BUTTON.

STANDARD TAPER: ROUND 1° PER SIDE/SHAPED 1-1/2° PER SIDE

Complete design & CAD files visit WWW.MOELLERMCD.COM

CATALOG TYPE	BODY DIA D	LAND LENGTH "B"				ROUND RANGE P	SHAPE		OVERALL LENGTH "L"								
		NAPMA		ALTERNATES			MIN W	MAX G/P	20	22	25	28	30	32	35	40	
		STD	A	B	C												
MU_08	8	4.0	8.0		3.0	1.5 - 3.20	1.5	3.20	X	X	X	X	X	X	X	X	
MU_10	10	4.0	8.0		3.0	1.6 - 5.0	1.6	5.0	X	X	X	X	X	X	X	X	X
MU_13	13	5.0	8.0		3.0	3.0 - 7.2	1.8	7.2	X	X	X	X	X	X	X	X	X
MU_16	16	5.0	8.0		3.0	5.0 - 8.8	2.5	8.8	X	X	X	X	X	X	X	X	X
MU_20	20	5.0	12.0	20.0	3.0	5.5 - 11.0	3.2	11.0	X	X	X	X	X	X	X	X	X
MU_22	22	6.0	12.0	20.0	3.0	7.5 - 14.0	4.0	14.0	X	X	X	X	X	X	X	X	X
MU_25	25	6.0	12.0	20.0	3.0	9.5 - 16.5	4.8	16.5	X	X	X	X	X	X	X	X	X
MU_32	32	6.0	12.0	20.0	3.0	13.0 - 20.0	5.5	20.0	X	X	X	X	X	X	X	X	X
MU_38	38	8.0	12.0	20.0	3.0	16.0 - 26.0	6.4	26.0	X	X	X	X	X	X	X	X	
MU_40	40	8.0	12.0	20.0	3.0	16.0 - 26.0	6.4	26.0	X	X	X	X	X	X	X	X	

Material

Steel: STD A2, HRC 58-60

(X) Alternate M2, HRC 60-63 (Must Specify)

Standard Point Tolerance

Round P $\begin{matrix} +.01 \\ -.00 \end{matrix}$ $\text{\textcircled{C}}$.01 P to D

Shape P, W $\begin{matrix} +.02 \\ -.00 \end{matrix}$ $\text{\textcircled{C}}$.02 P to D

Alternate Point Tolerance T2

P, W TOLERANCE $\begin{matrix} +.005 \\ -.000 \end{matrix}$

P to D $\begin{matrix} .008 \\ \text{\textcircled{C}} \end{matrix}$

ONLY AVAILABLE BELOW 45 BODY DIAMETER

STANDARD FLAT LOCATION IS AT 0° AS SHOWN. AVAILABLE AT 90°, 180°, 270°, FOR SAME ALTERATION PRICE.

ORDER EXAMPLE:

(Reference page 4)

SPECIFY:	QTY:	TYPE	"D"	"L"	"B"	LAND LENGTH DIMENSIONS	P(OR P&W) TOLERANCE	ALTERNATE TOLERANCE	ALTERATION CODE	STEEL
EXAMPLE:	6	MUC	25	30	A	15.0	T2	F2	A2	
EXAMPLE:	6	MUO	20	30	STD	10.0 x 5.0	STD	F2	M-2	

Note: When ordering, standard quantity breaks are: 1, 2-3, 4-11, 12-23, 24-49, 50-99

FOR SLUG CONTROL AND STANDARD ALTERATIONS SEE PAGES 74-80.

PRESS FIT BUTTONS

ULTRA LIFE/TAPER RELIEF/EXTENDED RANGE

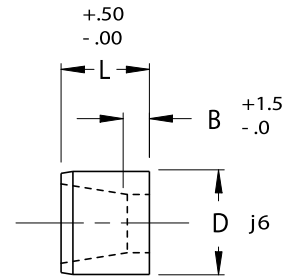
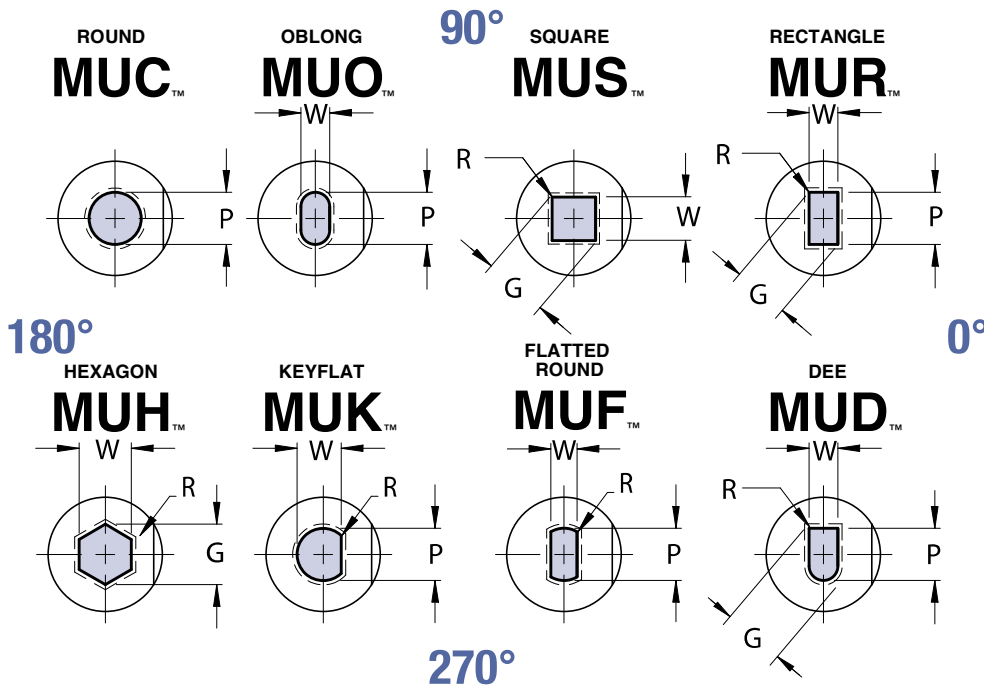

VIEWS ARE SHOWN LOOKING AT TOP FACE OF BUTTON.

STANDARD TAPER: ROUND 1° PER SIDE/SHAPED 1-1/2° PER SIDE

Complete design & CAD files visit WWW.MOELLERMCAD.COM

CATALOG TYPE	BODY DIA D	LAND LENGTH "B"				ROUND RANGE P	SHAPE		OVERALL LENGTH "L"				
		NAPMA	ALTERNATES				MIN W	MAX G/P	25	28	30	32	35
		STD	A	B	C								
MU_45	45	8.0	12.0	20.0	3.0	22.0 - 31.0	7.5	31.0	(X)	(X)	(X)	(X)	(X)
MU_50	50	8.0	12.0	20.0	3.0	24.0 - 34.0	8.0	34.0	(X)	(X)	(X)	(X)	(X)
MU_56	56	8.0	12.0	20.0	3.0	26.0 - 38.0	8.5	38.0	(X)	(X)	(X)	(X)	(X)
MU_63	63	8.0	12.0	20.0	3.0	30.0 - 43.0	9.0	43.0	(X)	(X)	(X)	(X)	(X)
MU_71	71	8.0	12.0	20.0	3.0	34.0 - 48.0	9.5	48.0	(X)	(X)	(X)	(X)	(X)
MU_76	76	8.0	12.0	20.0	3.0	36.0 - 52.0	10.0	52.0					(X)
MU_85	85	8.0	12.0	20.0	3.0	40.0 - 58.0	11.0	58.0					(X)
MU_90	90	8.0	12.0	20.0	3.0	43.0 - 61.0	12.0	61.0					(X)
MU_100	100	8.0	12.0	20.0	3.0	48.0 - 68.0	13.0	68.0					(X)

Material

Steel: STD A2, HRC 58-60

(X) Alternate M2, HRC 60-63 (Must Specify)

Standard Point Tolerance

Round P $\begin{matrix} +.01 \\ -.00 \end{matrix}$.01 P to D

Shape P, W $\begin{matrix} +.02 \\ -.00 \end{matrix}$.02 P to D

STANDARD FLAT LOCATION IS AT 0° AS SHOWN.
AVAILABLE AT 90°, 180°, 270°, FOR SAME ALTERATION PRICE.

ORDER EXAMPLE:

(Reference page 4)

SPECIFY:	QTY:	TYPE	"D"	"L"	"B"	LAND LENGTH DIMENSIONS	P (OR P&W) TOLERANCE	ALTERNATE TOLERANCE	ALTERATION CODE	STEEL
EXAMPLE:	6	MUC	50	30	A	35.0	T2	F2	A-2	
EXAMPLE:	6	MUO	63	25	STD	42.5 x 18.3	STD	F2	M-2	

Note: When ordering, standard quantity breaks are: 1, 2-3, 4-11, 12-23, 24-49, 50-99

FOR SLUG CONTROL AND STANDARD ALTERATIONS SEE PAGES 74-80.

SLIP-FIT BUTTONS

COUNTER BORE RELIEF

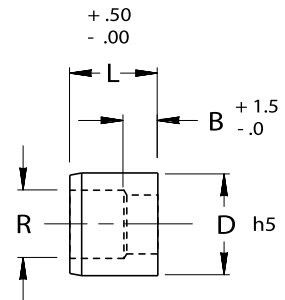
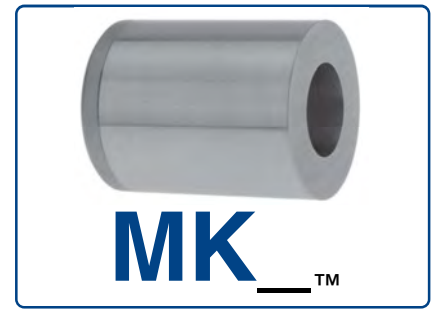
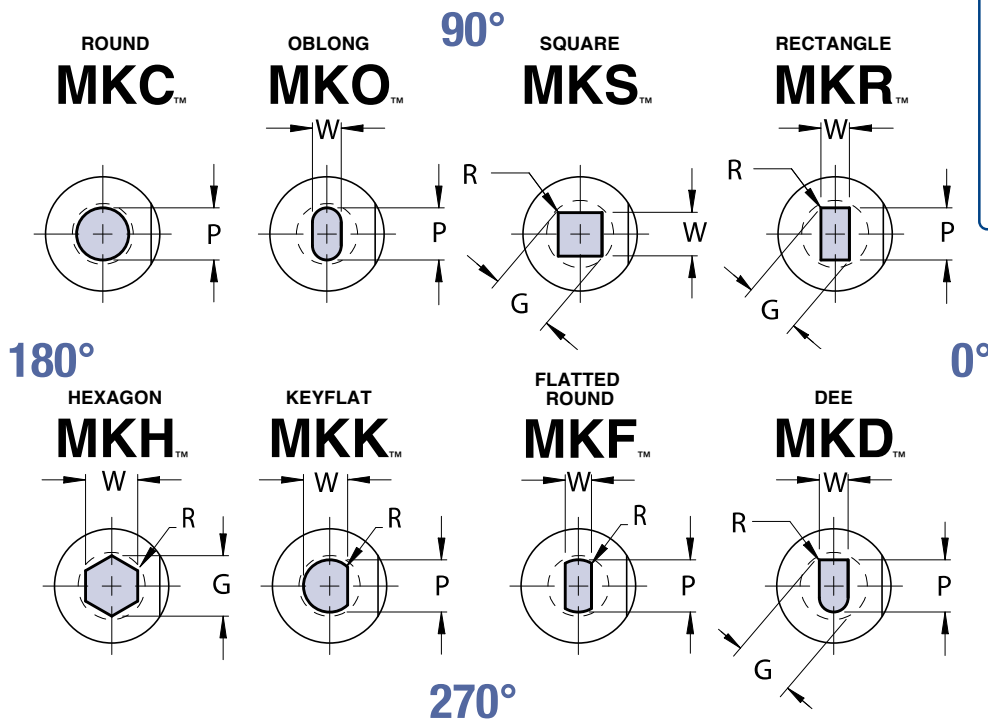

STANDARD FLAT LOCATION IS AT 0°. AS SHOWN AVAILABLE AT 90°, 180°, 270°, FOR SAME ALTERATION PRICE.

VIEWS ARE SHOWN LOOKING AT TOP FACE OF BUTTON.

*THESE LENGTHS ARE AVAILABLE WITH VDI STYLE RELIEF ONLY

Complete design & CAD files visit WWW.MOELLERMCD.COM

CATALOG TYPE	BODY DIA	LAND LENGTH "B"		ROUND RANGE P	SHAPE		RELIEF DIA	OVERALL LENGTH "L"	
		STANDARD	ALT A		MIN W	MAX P/G		25	32
MK_13	13	5	8	1.80 - 3.00	1.80	3.00	5.2	X	
		5	8	3.01 - 6.20	1.80	6.20	7.0	X	
MK_16	16	5	9	5.00 - 6.20	2.50	6.20	7.2	X	
		5	9	6.21 - 8.00	2.50	8.00	8.7	X	
MK_20	20	5	9	5.40 - 8.30	3.20	8.30	9.1	X	
		5	9	8.31 - 11.00	3.20	11.00	11.9	X	
MK_25	25	5	12	9.40 - 13.00	4.80	13.00	13.9	X*	X
		5	12	13.01 - 16.00	4.80	16.00	16.7	X*	X
MK_32	32	5	12	13.00 - 16.50	5.50	16.50	17.5	X*	X
		5	12	16.51 - 20.00	5.50	20.00	21.5	X*	X
MK_40	40	5	15	15.80 - 21.40	6.40	21.40	22.2	X*	X
		5	15	21.41 - 26.00	6.40	26.00	27.0	X*	X
MK_50	50	5	20	20.00 - 26.00	9.00	26.00	27.0		X
		5	20	26.01 - 37.00	9.00	37.00	38.0		X
MK_56	56	5	20	25.00 - 35.00	10.00	35.00	36.0		X
		5	20	35.01 - 44.00	10.00	44.00	45.0		X
MK_63	63	5	20	28.00 - 40.00	11.00	40.00	41.0		X
		5	20	40.01 - 50.00	11.00	50.00	51.0		X

Material

Steel: A2, HRC 59-61
M2 - CONSULT FACTORY

Standard Point Tolerance

Round P	+ .01 - .00		.01	P to D
Shape P, W	+ .02 - .0		.02	P to D

VDI ALTERATION -

FOR VDI STYLE RELIEF +.2/.3
OVER "P" OR "G" ADD VDI AT
END OF DESCRIPTION

ORDER EXAMPLE:

(Reference page 4)

SPECIFY:	QTY:	TYPE	"D"	"L"	"B"	LAND LENGTH DIMENSIONS	P (OR P&W) TOLERANCE	ALTERNATE TOLERANCE	ALTERATION CODE	STEEL
EXAMPLE:	6	MKC	25	32	A	15.0			F2	A-2
EXAMPLE:	6	MKO	20	25	STD	10.0 x 5.0		STD	F2	M-2

Note: When ordering, standard quantity breaks are: 1, 2-3, 4-11, 12-23, 24-49, 50-99

FOR SLUG CONTROL AND
STANDARD ALTERATIONS SEE PAGES 74-80.

SHOULDER BUTTONS

COUNTER BORE RELIEF

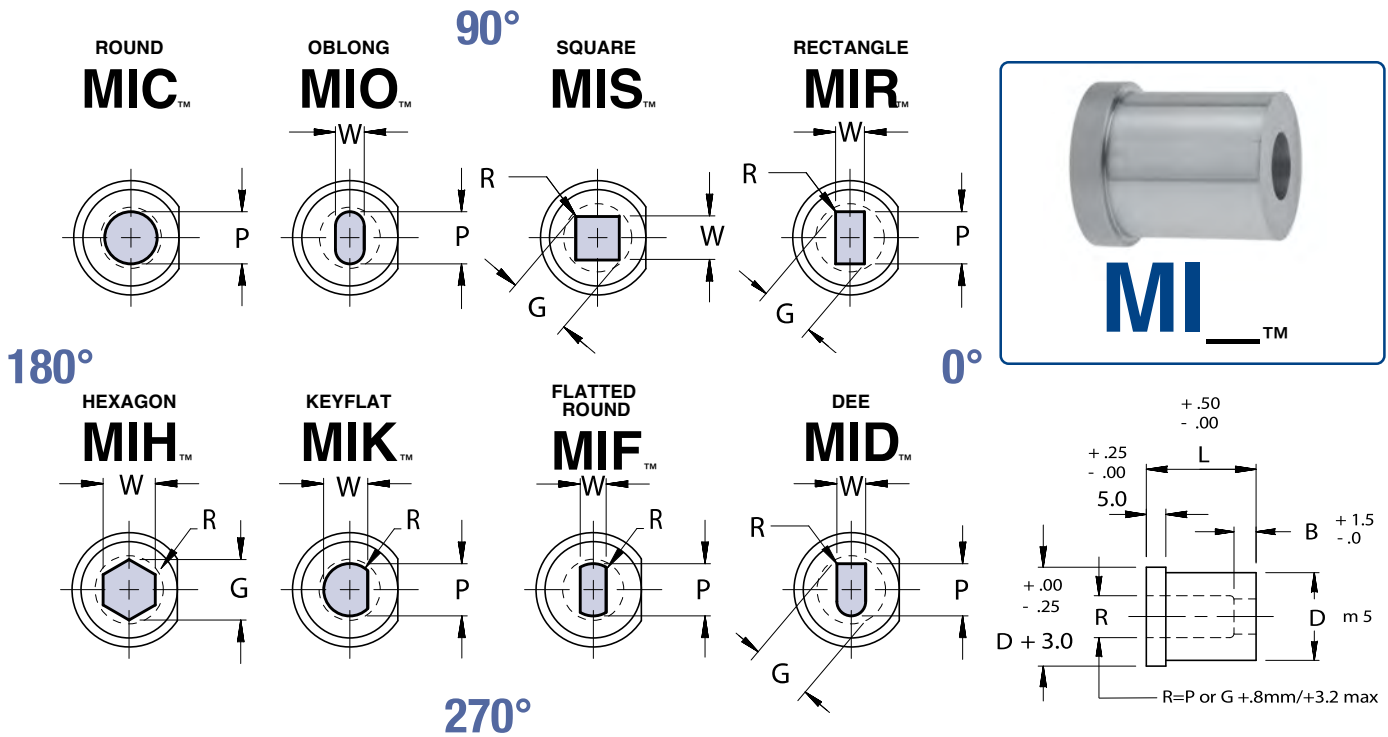

VIEWS ARE SHOWN LOOKING AT TOP FACE OF BUTTON.

Complete design & CAD files visit WWW.MOELLERMCAD.COM

CATALOG TYPE	BODY DIA D	LAND LENGTH "B"		MAX DIA R	SHAPE		OVERALL LENGTH "L"								
		STD	ALT A		ROUND RANGE P	MIN W	MAX G/P	20	22	25	28	30	32	35	
MI_08	8	4.0	8.0	4.0	1.50 - 3.20	1.50	3.20	(X)	(X)	(X)	(X)	(X)	(X)	(X)	(X)
MI_10	10	4.0	8.0	6.0	1.60 - 5.00	1.60	5.00	(X)	(X)	(X)	(X)	(X)	(X)	(X)	(X)
MI_13	13	5.0	8.0	8.0	1.80 - 7.20	1.80	7.20	(X)	(X)	(X)	(X)	(X)	(X)	(X)	(X)
MI_16	16	5.0	8.0	9.5	5.00 - 8.80	2.50	8.80	(X)	(X)	(X)	(X)	(X)	(X)	(X)	(X)
MI_20	20	5.0	12.0	12.0	5.50 - 11.00	3.20	11.00	(X)	(X)	(X)	(X)	(X)	(X)	(X)	(X)
MI_22	22	6.0	12.0	15.0	7.50 - 14.00	4.00	14.00	(X)	(X)	(X)	(X)	(X)	(X)	(X)	(X)
MI_25	25	6.0	12.0	17.5	9.50 - 16.50	4.80	16.50	(X)	(X)	(X)	(X)	(X)	(X)	(X)	(X)
MI_32	32	6.0	12.0	21.0	13.00 - 20.00	5.50	20.00	(X)	(X)	(X)	(X)	(X)	(X)	(X)	(X)
MI_38	38	8.0	12.0	27.0	16.00 - 26.00	6.40	26.00	(X)	(X)	(X)	(X)	(X)	(X)	(X)	(X)
MI_40	40	8.0	12.0	27.0	16.00 - 26.00	6.50	26.00	(X)	(X)	(X)	(X)	(X)	(X)	(X)	(X)

Material

Steel: A2, HRC 58-60

(X) Alternate M2, HRC 60-63 (Must Specify)

Standard Point Tolerance

Round P $\begin{matrix} +.01 \\ -.00 \end{matrix}$.01 P to D

Shape P, W $\begin{matrix} +.02 \\ -.0 \end{matrix}$.02 P to D

ORDER EXAMPLE:

(Reference page 4)

SPECIFY:	QTY:	TYPE	"D"	"L"	"B"	P(OR P&W) DIMENSIONS	ALTERATION CODE	STEEL
EXAMPLE:	6	MIC	13	25	A	6.0	F1	M-2
EXAMPLE:	6	MIO	20	25	STD	9.0 x 4.0	F1	A-2

Note: When ordering, standard quantity breaks are: 1, 2-3, 4-11, 12-23, 24-49, 50-99

FOR SLUG CONTROL AND STANDARD ALTERATIONS SEE PAGES 74-80.

STANDARD FLAT LOCATION IS AT 0° AS SHOWN. AVAILABLE AT 90°, 180°, 270°, FOR SAME ALTERATION PRICE.

SHOULDER BUTTONS

ULTRA LIFE/TAPER RELIEF

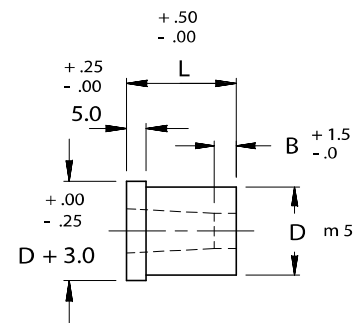
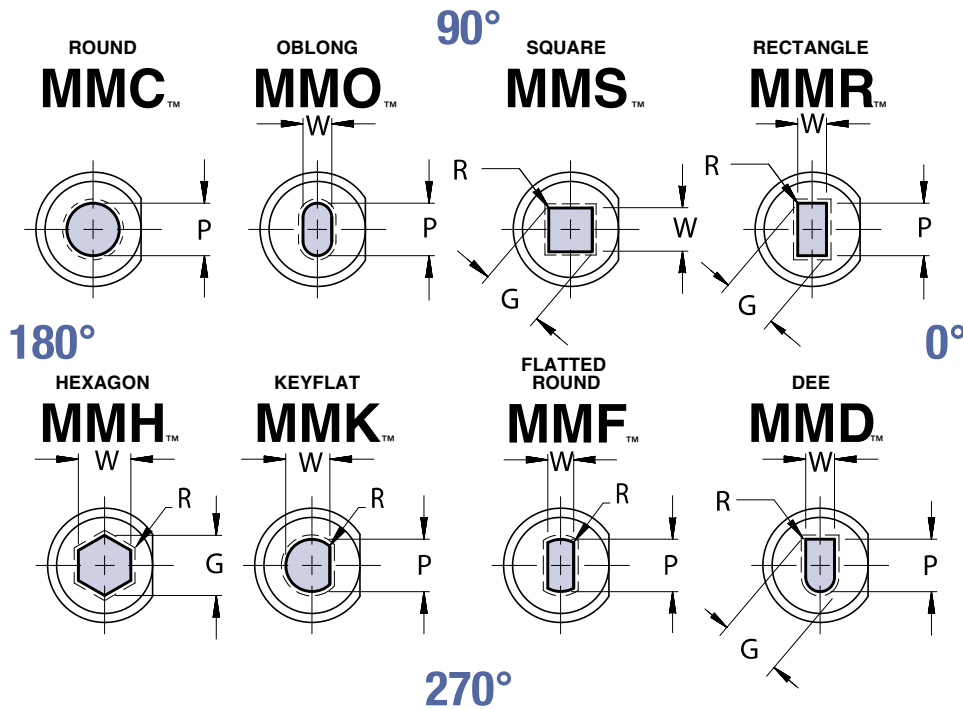

VIEWS ARE SHOWN LOOKING AT TOP FACE OF BUTTON.

STANDARD TAPER: ROUND 1° PER SIDE/SHAPED 1-1/2° PER SIDE

Complete design & CAD files visit WWW.MOELLERMCAD.COM

CATALOG TYPE	BODY DIA D	LAND LENGTH "B"				ROUND RANGE P	SHAPE		OVERALL LENGTH "L"						
		NAPMA		ALTERNATES			MIN W	MAX G/P	20	22	25	28	30	32	35
		STD	A	B	C										
MM_08	8	4.0	8.0		3.0	1.50 - 3.20	1.50	3.20	X	X	X	X	X	X	X
MM_10	10	4.0	8.0		3.0	1.60 - 5.00	1.60	5.00	X	X	X	X	X	X	X
MM_13	13	5.0	8.0		3.0	1.80 - 7.20	1.80	7.20	X	X	X	X	X	X	X
MM_16	16	5.0	8.0		3.0	5.00 - 8.80	2.50	8.80	X	X	X	X	X	X	X
MM_20	20	5.0	12.0	20.0	3.0	5.50 - 11.00	3.20	11.00	X	X	X	X	X	X	X
MM_22	22	6.0	12.0	20.0	3.0	7.50 - 14.00	4.00	14.00	X	X	X	X	X	X	X
MM_25	25	6.0	12.0	20.0	3.0	9.50 - 16.50	4.80	16.50	X	X	X	X	X	X	X
MM_32	32	6.0	12.0	20.0	3.0	13.00 - 20.00	5.50	20.00	X	X	X	X	X	X	X
MM_38	38	8.0	12.0	20.0	3.0	16.00 - 26.00	6.40	26.00	X	X	X	X	X	X	X
MM_40	40	8.0	12.0	20.0	3.0	16.00 - 26.00	6.50	26.00	X	X	X	X	X	X	X
MM_45	45	8.0	12.0	20.0	3.0	22.00 - 31.00	7.50	31.00		X	X	X	X	X	X

Material

Steel: M2, HRC 60-63

Standard Point Tolerance

Round P $\begin{matrix} +.01 \\ -.00 \end{matrix}$

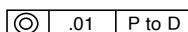

Shape P, W $\begin{matrix} +.02 \\ -.00 \end{matrix}$

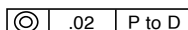

Alternate Hole Tolerance T2

P, W TOLERANCE $\begin{matrix} +.005 \\ -.000 \end{matrix}$

P to D $\begin{matrix} .008 \\ \text{circle with horizontal line} \end{matrix}$

ORDER EXAMPLE:

(Reference page 4)

SPECIFY:	QTY:	TYPE	"D"	"L"	"B"	P(OR P&W) DIMENSIONS	ALTERNATE TOLERANCE	ALTERATION CODE
EXAMPLE:	6	MMC	13	25	C	6.0	STD	F1
EXAMPLE:	6	MMS	20	30	A	9.0	T2	F1

Note: When ordering, standard quantity breaks are: 1, 2-3, 4-11, 12-23, 24-49, 50-99

FOR SLUG CONTROL AND STANDARD ALTERATIONS SEE PAGES 74-80.

STANDARD FLAT LOCATION IS AT 0° AS SHOWN. AVAILABLE AT 90°, 180°, 270°, FOR SAME ALTERATION PRICE.

BALL LOCK BUTTONS

COUNTER BORE RELIEF

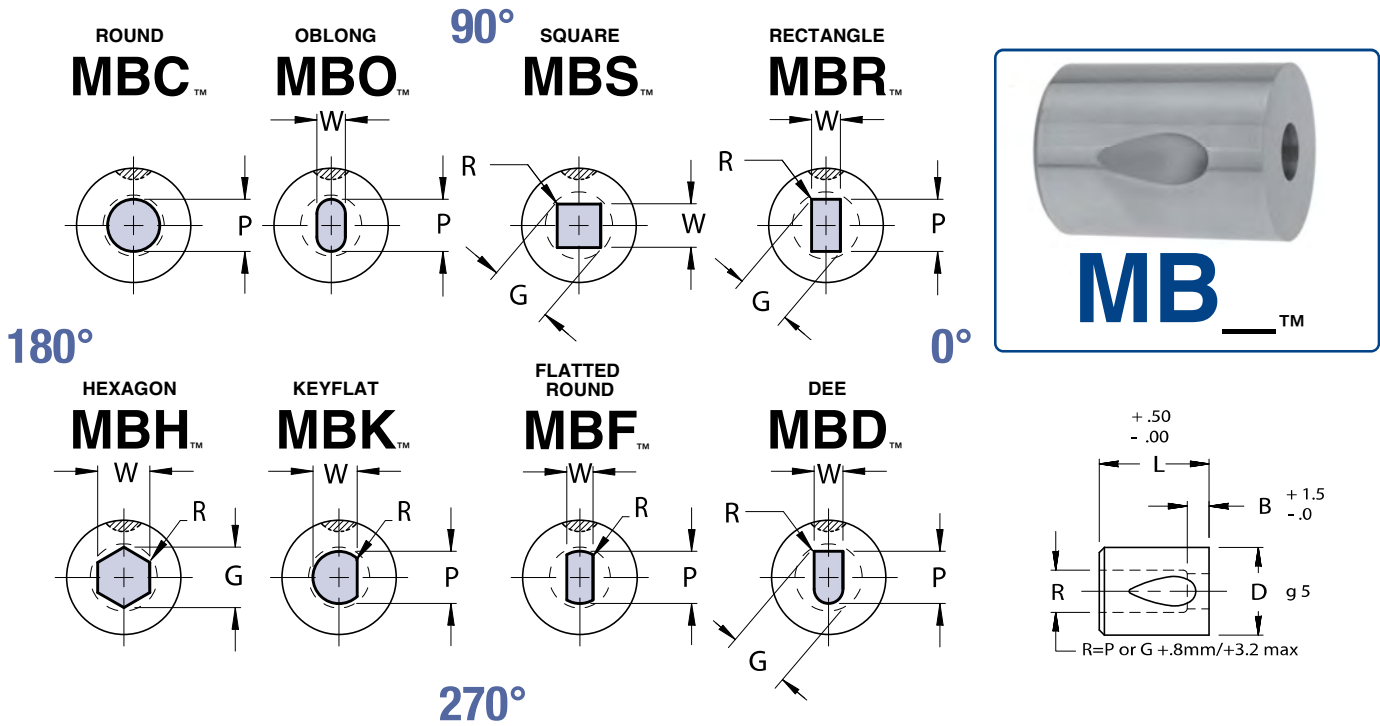

VIEWS ARE SHOWN LOOKING AT TOP FACE OF BUTTON.

Complete design & CAD files visit WWW.MOELLERMCAD.COM

CATALOG TYPE	BODY DIA D	DIE LAND B	MAX DIA R	ROUND	SHAPE		OVERALL LENGTH "L"
				RANGE P	MIN W	MAX G/P	32
MB_13	13	4.0	6.0	1.60 - 5.00	1.60	5.00	X
MB_16	16	5.0	8.0	3.20 - 7.20	2.00	7.20	X
MB_20	20	5.0	12.0	4.00 - 11.00	2.50	11.00	X
MB_25	25	6.0	16.0	8.00 - 15.00	4.00	15.00	X
MB_32	32	6.0	20.0	11.00 - 19.00	5.00	19.00	X

Material

Steel: A2, HRC 58-60

Standard Point Tolerance

Round P $\begin{matrix} +.01 \\ -.00 \end{matrix}$.01 P to D

Shape P, W $\begin{matrix} +.02 \\ -.00 \end{matrix}$.02 P to D

ORDER EXAMPLE:

(Reference page 4)

P(OR P&W)

SPECIFY: QTY: TYPE "D" "L" DIMENSIONS

EXAMPLE: 6 MBC 16 32 5.0

EXAMPLE: 6 MBO 20 32 9.0 x 4.0

Note: When ordering, standard quantity breaks are:

1, 2-3, 4-11, 12-23, 24-49, 50-99

FOR SLUG CONTROL AND STANDARD ALTERATIONS SEE PAGES 74-80.

STANDARD BALL SEAT LOCATION IS AT 90° AS SHOWN. AVAILABLE AT 0°, 180°, 270°, FOR SAME ALTERATION PRICE.

BUTTON BLANKS

WITH COUNTER BORE RELIEF

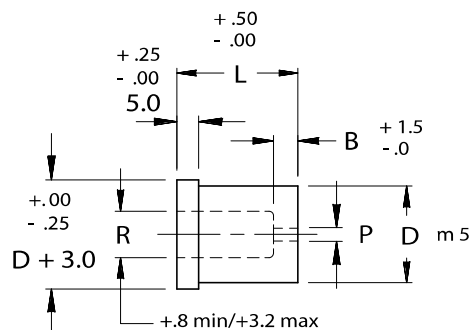
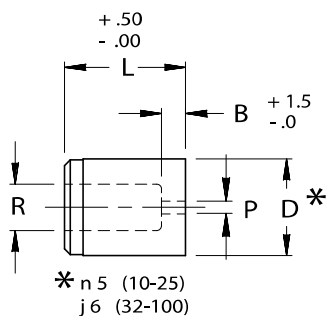

Material

Steel: A2, HRC 58-60

ORDER EXAMPLE:

(Reference page 4)

SPECIFY: QTY: TYPE "D" "L"

EXAMPLE: 6 MDB 16 28

EXAMPLE: 6 MIB 25 30

STANDARD ALTERATIONS SEE PAGES 74-80.

Complete design & CAD files visit WWW.MOELLERMCAD.COM

CATALOG NUMBER	BODY DIA D	DIE LAND B	RLF DIA R	DRILL SIZE P	OVERALL LENGTH "L"						
					20	22	25	28	30	32	35
M_B 08	8	4.0	4.0	1.2	X	X	X	X	X	X	X
M_B 10	10	4.0	6.0	1.2	X	X	X	X	X	X	X
M_B 13	13	5.0	8.0	1.4	X	X	X	X	X	X	X
M_B 16	16	5.0	9.5	2.0	X	X	X	X	X	X	X
M_B 20	20	5.0	12.0	2.8	X	X	X	X	X	X	X
M_B 22	22	6.0	15.0	2.8	X	X	X	X	X	X	X
M_B 25	25	6.0	17.5	4.4	X	X	X	X	X	X	X
M_B 32	32	6.0	21.0	5.2	X	X	X	X	X	X	X
M_B 38	38	8.0	27.0	5.6		X	X	X	X	X	X
M_B 40	40	8.0	27.0	5.6		X	X	X	X	X	X

BUTTON BLANKS

WITH STRAIGHT THRU HOLE

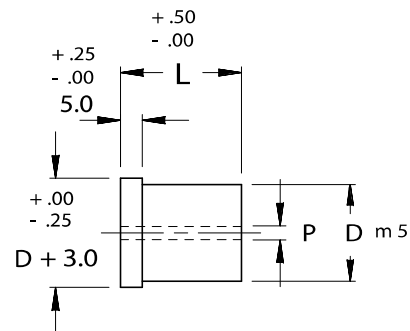
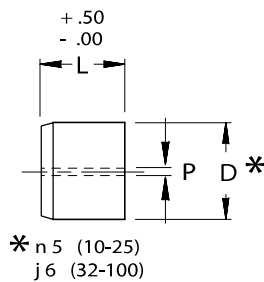

Material

Steel: M2, HRC 60-63

ORDER EXAMPLE:

(Reference page 4)

SPECIFY: QTY: TYPE "D" "L"
 EXAMPLE: 6 MUB 40 30
 EXAMPLE: 6 MMB 20 32

Complete design & CAD files visit WWW.MOELLERMCAD.COM

STANDARD ALTERATIONS SEE PAGES 74-80.

CATALOG NUMBER	BODY DIA D	DRILL SIZE P	OVERALL LENGTH "L"						
			20	22	25	28	30	32	35
M_B 08	8	1.2	X	X	X	X	X	X	X
M_B 10	10	1.2	X	X	X	X	X	X	X
M_B 13	13	1.4	X	X	X	X	X	X	X
M_B 16	16	2.0	X	X	X	X	X	X	X
M_B 20	20	2.4	X	X	X	X	X	X	X
M_B 22	22	2.4	X	X	X	X	X	X	X
M_B 25	25	2.4	X	X	X	X	X	X	X
M_B 32	32	2.4	X	X	X	X	X	X	X
M_B 38	38	2.4	X	X	X	X	X	X	X
M_B 40	40	2.4	X	X	X	X	X	X	X
M_B 45	45	2.4			X	X	X	X	X
MUB 50*	50	2.4			X	X	X		X
MUB 56*	56	2.4			X	X	X		X
MUB 63*	63	2.4			X	X	X		X
MUB 71*	71	2.4			X	X	X		X
MUB 76*	76	2.4			X	X	X		X
MUB 85*	85	2.4			X	X	X		X
MUB 90*	90	2.4			X	X	X		X
MUB 100*	100	2.4			X	X	X		X

*Available in MUB Only

BUTTON BLANKS

BALL LOCK WITH COUNTER BORE RELIEF AND STRAIGHT THRU HOLE

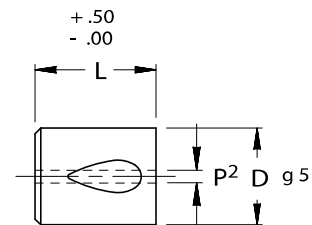
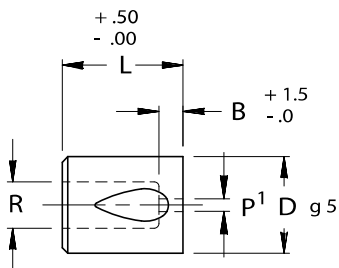

Material
Steel: A2, HRC 58-60

Material
Steel: M2, HRC 60-63

ORDER EXAMPLE:
(Reference page 4)
SPECIFY: QTY: TYPE "D" "L"
EXAMPLE: 6 MBB 16 32
EXAMPLE: 6 MFB 20 32

Complete design & CAD files visit WWW.MOELLERMCAD.COM

STANDARD ALTERATIONS SEE PAGES 74-80.

CATALOG NUMBER	BODY DIA D	DIE LAND B	RLF DIA R	DRILL SIZE P ¹	DRILL SIZE P ²	OVERALL LENGTH "L"
						32
M_B 13	13	4.0	5.8	1.2	1.2	X
M_B 16	16	5.0	8.0	1.6	1.6	X
M_B 20	20	5.0	11.9	2.0	2.0	X
M_B 25	25	6.0	16.0	3.6	2.4	X
M_B 32	32	6.0	20.0	4.4	2.4	X

UNIVERSAL SHAPES

Views are shown looking through the shank of punch and top of button, as in true die position. Standard ballseat location is at 90°, standard flat location is at 0°. Points are centered on shanks unless noted by drawing. Female corners on buttons will be furnished with a .2 radius to facilitate wire EDM. To order the first character is M, then specify body type similar to other standard items, (second alpha characters), then "U" as the third alpha character. ADD an alteration code U-__ to describe universal shape.

ORDER EXAMPLE: MHU 32-090 P=24.5 W=16.6 R=1.5, U-17

MISCELLANEOUS

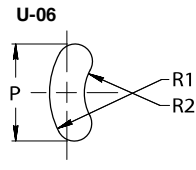
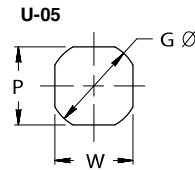

90°

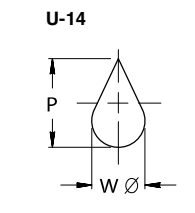
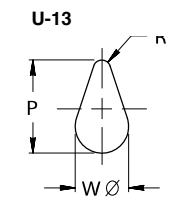
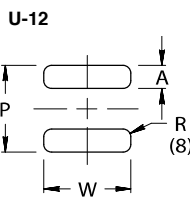
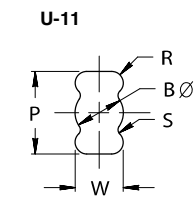
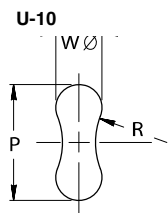
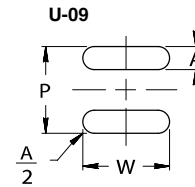
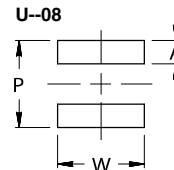
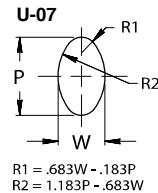

TRIANGLES/TRAPEZOIDS

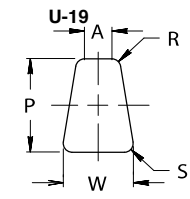
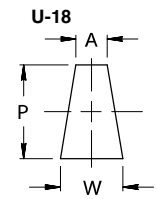
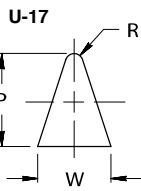
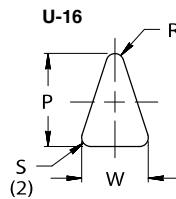
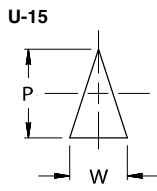

MONO LOBES

180°

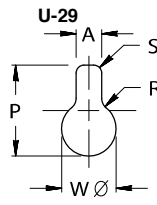
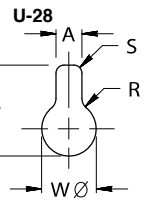
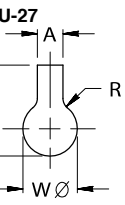
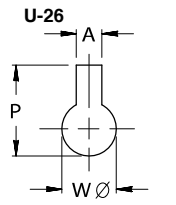
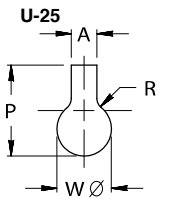
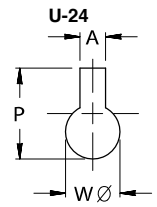
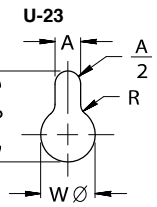
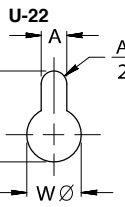
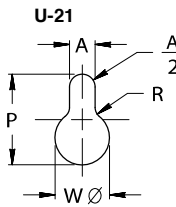
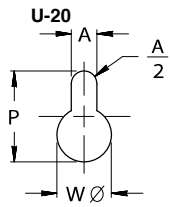

MULTI LOBES

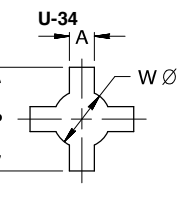
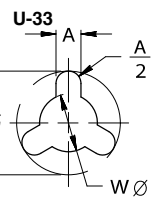
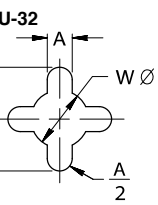
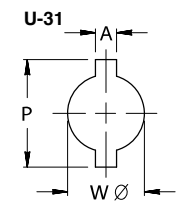
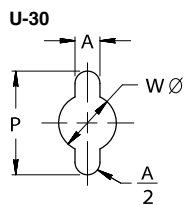

0°

270°

UNIVERSAL SHAPES

Views are shown looking through the shank of punch and top of button, as in true die position. Standard ballseat location is at 90°, standard flat location is at 0°. Points are centered on shanks unless noted by drawing. Female corners on buttons will be furnished with a .2 radius to facilitate wire EDM. To order, the first character is M, then specify body type similar to other standard items, (second alpha characters), then "U" as the third alpha character. ADD an alteration code U-__ to describe universal shape.

ORDER EXAMPLE: MHU32-090 P=24.5 W=16.6 B=5.5 A=5.5, U-38

U's

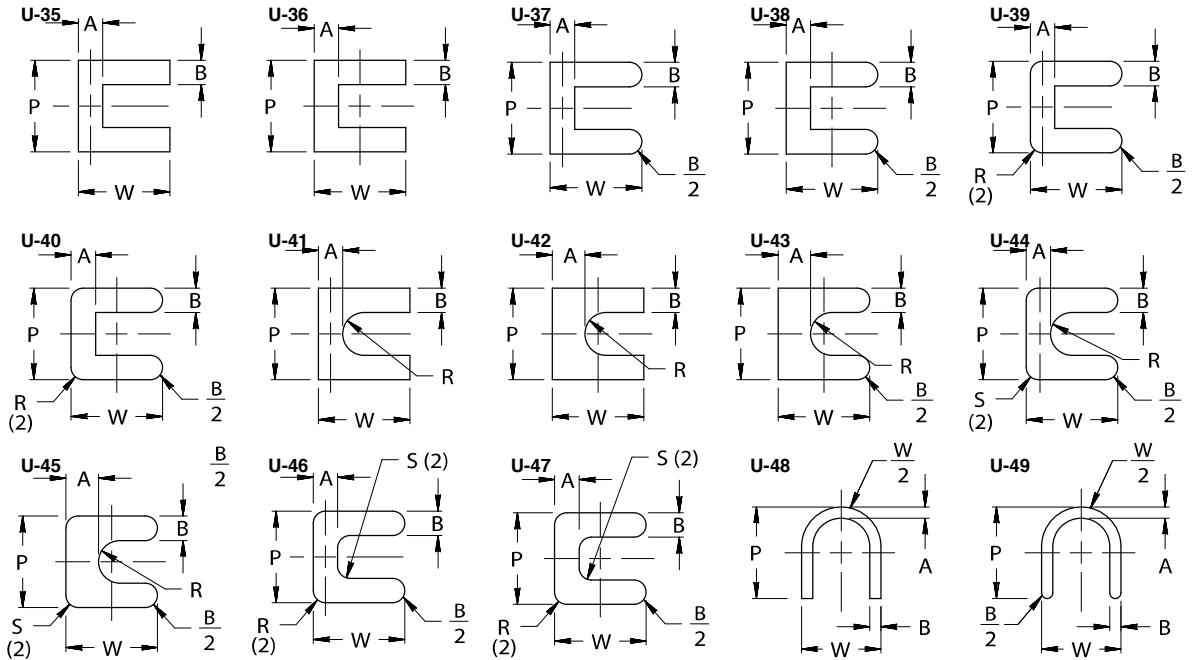

90°

L's

180°

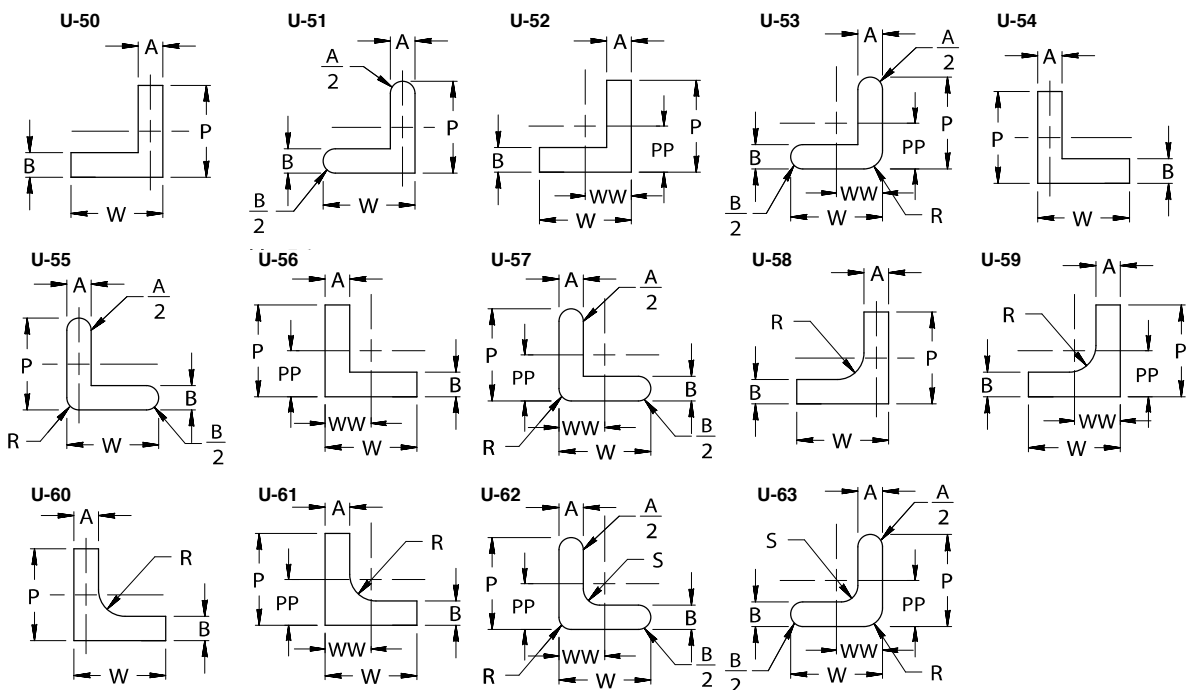

0°

270°

UNIVERSAL SHAPES

Views are shown looking through the shank of punch and top of button, as in true die position. Standard ballseat location is at 90°, standard flat location is at 0°. Points are centered on shanks unless noted by drawing. Female corners on buttons will be furnished with a .2 radius to facilitate wire EDM. To order, the first character is M, then specify body type similar to other standard items, (second alpha characters), then "U" as the third alpha character. ADD an alteration code U-__ to describe universal shape.

ORDER EXAMPLE: MHU25-100 P=23.5 W=16 R=1.5, U-81

T's

90°

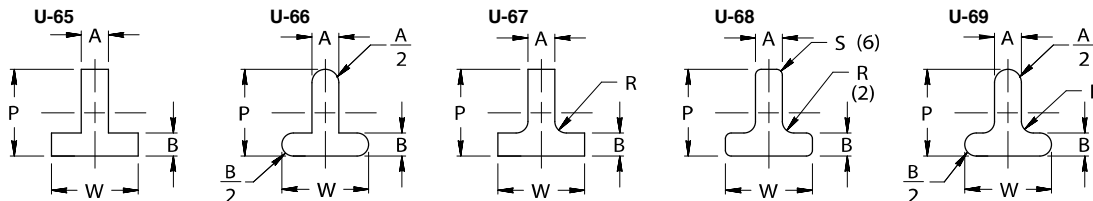

DUO TEES

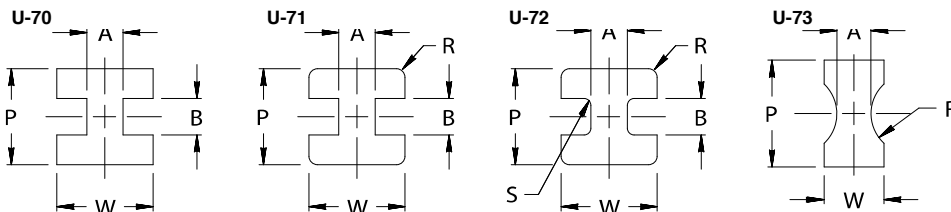

POLYGONS

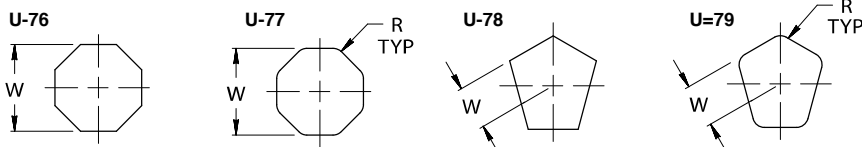

A = EVEN NO. OF SIDES

A = EVEN NO. OF SIDES

A = ODD NO. OF SIDES

A = ODD NO. OF SIDES

180°

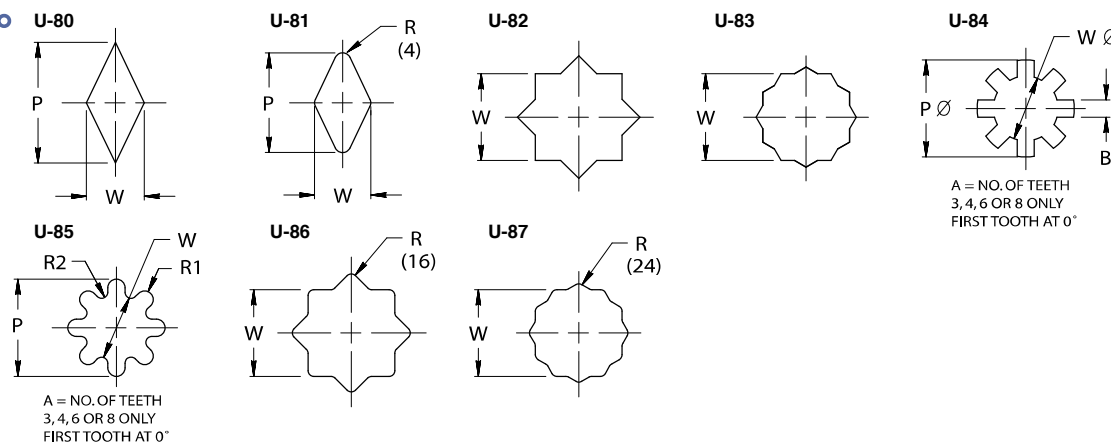

0°

KEYS

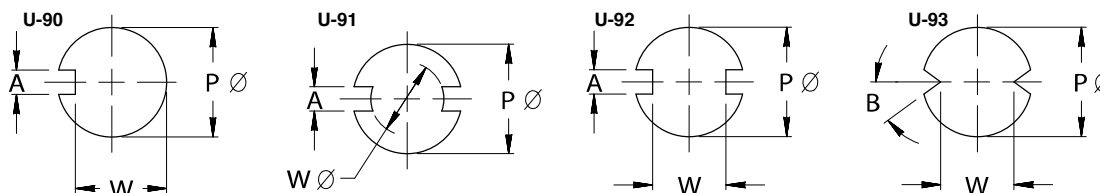

270°



BALL LOCK RETAINERS



TRUE SET-ADVANCED

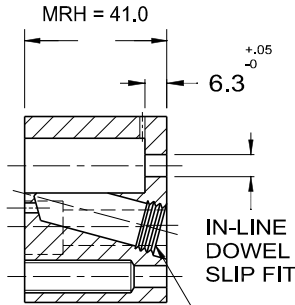
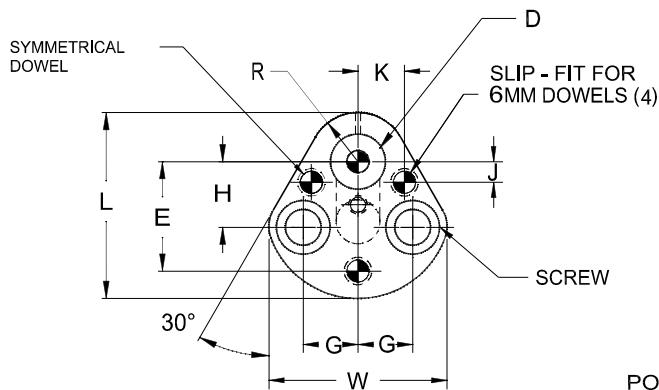

POSITIVE RETENTION
SET SCREW
AND BOOSTER SPRING



Manufactured under Patent No.'s 0351395, 5357835

FOR ACCESSORIES AND SHIM PLATES,
SEE PAGE 67.



- Advanced Design for the most demanding stamping applications, such as AHSS and Aluminum.
- The Industry's only True One-Piece construction produced from through-hardened shock resistant Tool steel.
- *True Set Exclusive* - Booster spring & positive Ball-Lock retention system resistant to shock resulting to Punch retention failure.
- Symmetrical 4th dowel providing increased versatility. Compatible with all predominant Global OEM Die Standards.

Heavy Duty

Complete design & CAD files visit WWW.MOELLERMCAD.COM

CATALOG NUMBER	D DIA.	±.01 E	G	L	W	R	H	±.01 J	±.01 K	IN-LINE DOWEL	SCREW SIZE
MRH 10A	10	26.924	11.12	44.5	39.9	9.5	19.05	7.50	9.00	6	M8
MRH 13A	13	29.972	14.27	50.8	48.3	12.7	19.05	6.50	12.00	6	M8
MRH 16A	16	31.750	15.87	54.0	51.6	14.3	19.05	6.00	13.50	6	M8
MRH 20A	20	33.528	17.47	60.3	58.2	17.5	19.05	5.00	16.50	6	M10
MRH 25A	25	40.640	19.84	69.9	66.5	22.2	23.82	7.00	22.00	6	M12
MRH 32A	32	40.640	19.84	69.9	66.5	22.2	23.82	7.00	22.00	6	M12
MRH 40A	40	43.993	24.00	77.4	77.8	26.0	27.00	10.00	26.00	6	M12



BALL LOCK RETAINERS



TRUE SET-STANDARD

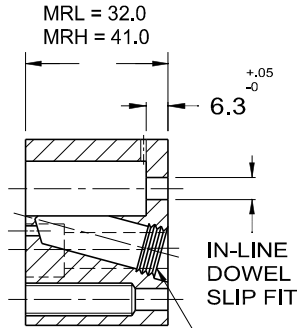
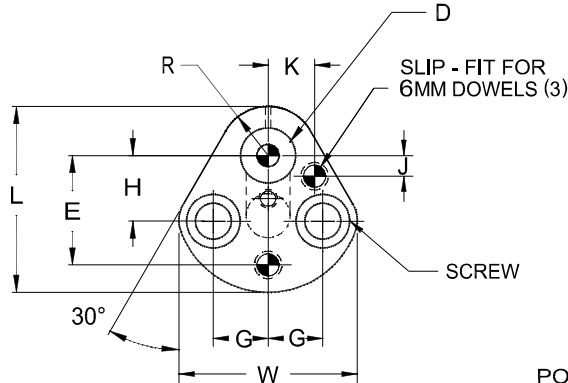

Manufactured under Patent No.'s 0351395, 5357835

FOR ACCESSORIES AND SHIM PLATES,
SEE PAGES 67.

Heavy Duty - MRH[®]

Complete design & CAD files visit WWW.MOELLERMCAD.COM

CATALOG NUMBER	D DIA.	±.01 E	G	L	W	R	H	±.01 J	±.01 K	IN-LINE DOWEL	SCREW SIZE
MRH 10	10	26.924	11.12	44.5	39.9	9.5	19.05	7.50	9.00	6	M8
MRH 13	13	29.972	14.27	50.8	48.3	12.7	19.05	6.50	12.00	6	M8
MRH 16	16	31.750	15.87	54.0	51.6	14.3	19.05	6.00	13.50	6	M8
MRH 20	20	33.528	17.47	60.3	58.2	17.5	19.05	5.00	16.50	6	M10
MRH 25	25	40.640	19.84	69.9	66.5	22.2	23.82	7.00	22.00	6	M12
MRH 32	32	40.640	19.84	69.9	66.5	22.2	23.82	7.00	22.00	6	M12
MRH 40	40	43.993	24.00	77.4	77.8	26.0	27.00	10.00	26.00	6	M12

Light Duty - MRL[™]

Complete design & CAD files visit WWW.MOELLERMCAD.COM

CATALOG NUMBER	D DIA.	±.01 E	G	L	W	R	H	±.01 J	±.01 K	IN-LINE DOWEL	SCREW SIZE
MRL 06	06	23.000	11.10	41.3	37.8	8.0	19.00	9.00	8.00	3*	M6
MRL 10	10	26.924	11.12	44.5	39.9	9.5	19.05	7.50	9.00	6	M8
MRL 13	13	29.972	14.27	50.8	48.3	12.7	19.05	6.50	12.00	6	M8
MRL 16	16	31.750	15.87	54.0	51.6	14.3	19.05	6.00	13.50	6	M8
MRL 20	20	33.528	17.47	60.3	58.2	17.5	19.05	5.00	16.50	6	M10
MRL 25	25	40.640	19.84	69.9	66.5	22.2	23.82	7.00	22.00	6	M12
MRL 32	32	40.640	19.84	69.9	66.5	22.2	23.82	7.00	22.00	6	M12
MRL 38	38	43.993	24.00	77.4	77.8	26.0	27.00	10.00	26.00	6	M12



BALL LOCK RETAINERS



ECONOMY ROUND TRUE SET HEAVY DUTY

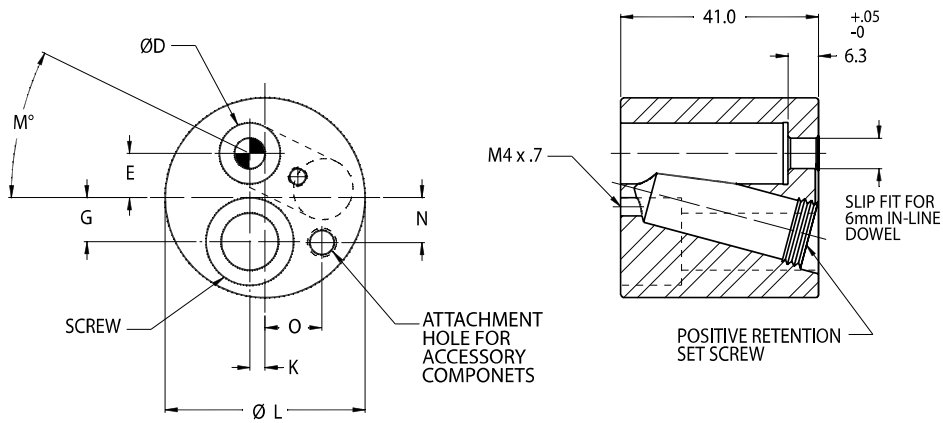

Manufactured under US Patent 8,459,161 B2
European Patent EP 2004368

FOR ACCESSORIES AND SHIM PLATES SEE PAGE 67.

Complete design & CAD files visit WWW.MOELLERMCAD.COM

CATALOG NUMBER	ØD	ØL	E	G	K	M	N	O	SCREW SIZE	IN-LINE DOWEL	ATTACHMENT HOLE
MRR 10	10.00	38.1	9.86	7.10	2.65	20.5°	4.47	12.72	M12	6	M6 x 1.0
MRR 13	13.00	41.3	9.25	9.17	3.18	26°	9.35	11.88	M12	6	M6 x 1.0
MRR 16	16.00	44.5	9.10	11.07	1.93	33.5°	10.21	13.16	M12	6	M6 x 1.0
MRR 20	20.00	57.2	12.20	14.30	0	30°	9.35	19.40	M16	6	M8 x 1.25
MRR 25	25.00	63.5	12.51	17.50	0	30°	14.27	20.17	M16	6	M8 x 1.25
MRR 32	32.00	76.2	15.67	20.83	0	30°	15.46	26.12	M20	6	M8 x 1.25
MRR 40	40.00	82.6	15.39	23.55	0	30°	15.46	26.12	M20	6	M8 x 1.25



BALL LOCK RETAINERS



MINI TRUE SET

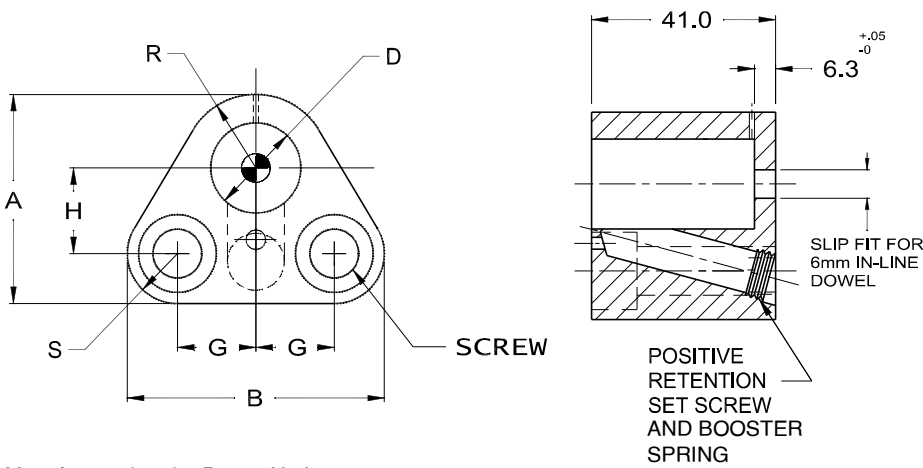

Manufactured under Patent No.'s 0351395, 5357835

FOR ACCESSORIES SEE PAGES 67.

Heavy Duty

Complete design & CAD files visit WWW.MOELLERMCAD.COM

CATALOG NUMBER	DIA.	A	B	G	H	R	S	SCREW SIZE
MRM 10	10	37.8	40.6	11.1	19.0	9.5	9.2	M8
MRM 13	13	40.3	47.6	14.3	19.0	11.7	9.5	M8
MRM 16	16	42.1	50.8	15.9	19.0	13.5	9.5	M8
MRM 20	20	46.5	57.1	17.5	19.0	16.4	11.1	M10
MRM 25	25	56.5	65.1	19.8	23.8	20.0	12.7	M12
MRM 32	32	58.2	64.0	19.8	23.8	22.2	12.2	M12
MRM 40	40	67.3	76.2	24.0	27.0	26.0	14.3	M12

SHIM PLATES

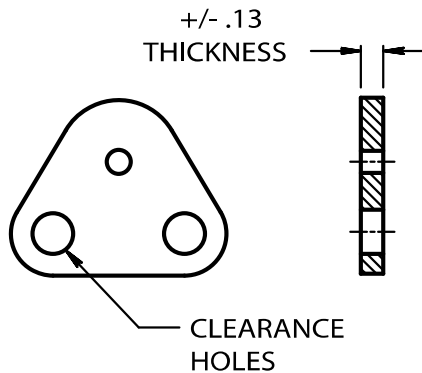

Available Thickness	Ordering Number
3.0	030
6.0	060
10.0	100
13.0	130

CATALOG NUMBER
MAM 10-
MAM 13-
MAM 16-
MAM 20-
MAM 25-
MAM 32-
MAM 40-

INSERT SHIM
ORDERING NUMBER

ORDERING EXAMPLE
MAM 16-060



INSERTABLE PUNCH RETAINERS



TRUE-FIT-HEAVY DUTY BALL LOCK

MRI TRUE-SET STYLE

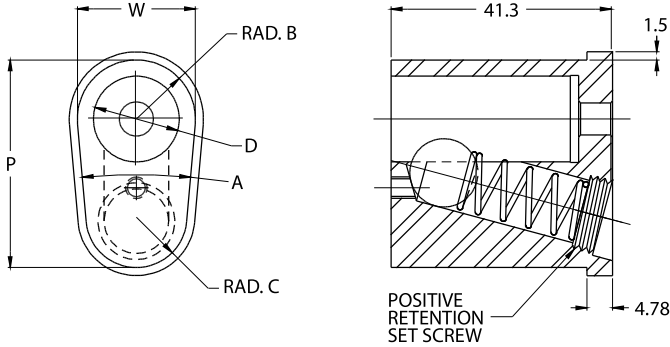

MRJ BACKING PLATE STYLE

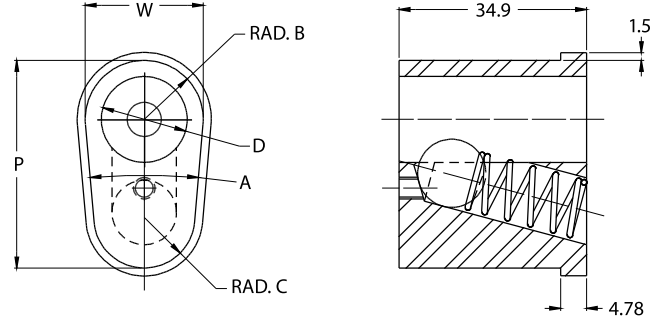

CATALOG TYPE	D	P	W	A	RAD. B	RAD. C
MR_010	10	29.48	15.88	5°	7.94	7.32
MR_013	13	36.04	19.05	5°	9.53	8.75
MR_016	16	39.21	22.23	10°	11.11	9.49
MR_020	20	42.39	25.4	10°	12.70	11.08
MR_025	25	48.74	31.75	30°	15.88	9.94
MR_032	32	55.09	38.10	30°	19.05	13.12
MR_040	40	63.69	48.00	30°	24.00	18.52

HOLE DIMENSIONS FOR TRUE-FIT INSERTS

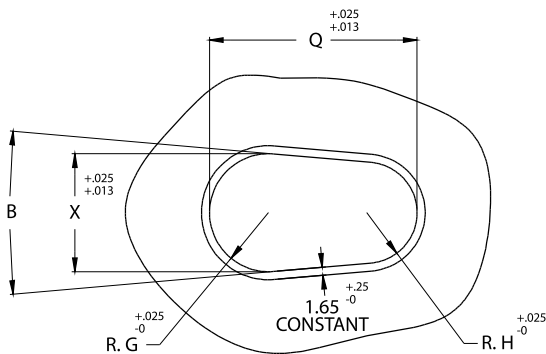

PUNCH SHANK Ø	Q	X	B	RAD. G	RAD. H
10	29.494	15.885	5°	7.943	7.323
13	36.048	19.060	5°	9.530	8.755
16	39.223	22.235	10°	11.118	9.497
20	42.398	25.410	10°	12.705	11.085
25	48.748	31.760	30°	15.880	9.949
32	55.098	38.110	30°	19.055	13.124
40	63.699	48.010	30°	24.005	18.526

MRI TRUE-SET STYLE

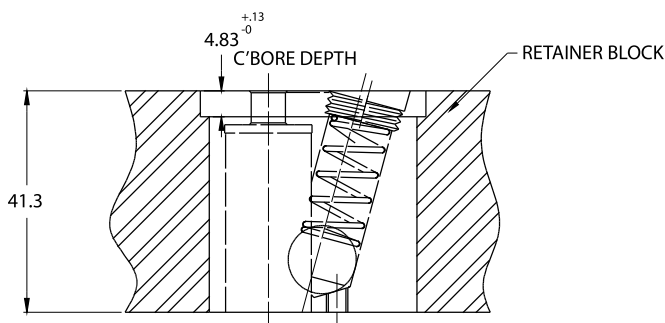

MRJ BACKING PLATE STYLE

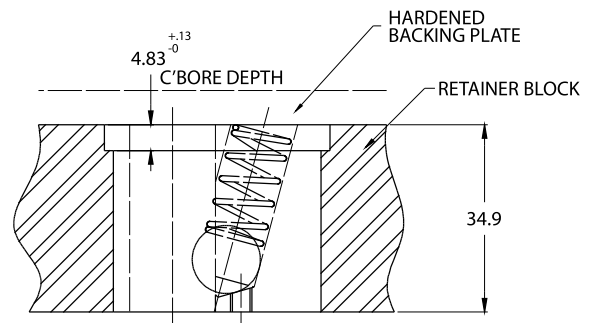

BALL LOCK RETAINERS

ECONOMY BALL LOCK INSERT BACKING PLATE STYLE ONLY

CATALOG NUMBER	ØA	ØB	ØC	D	E	F
MRK01	10	16	19.6	10	34.7	8
MRK013	13	20	24.6	11.5	34.7	10
MRK016	16	20	24.6	13	34.7	10
MRK020	20	20	24.6	15	34.7	10
MRK025	25	20	24.6	17.5	34.7	10
MRK032	32	20	24.6	21	34.7	10
MRK040	40	20	24.6	25	34.7	10

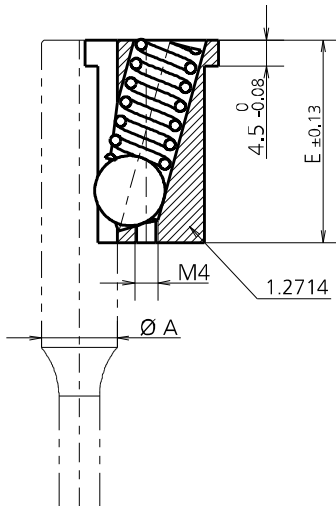
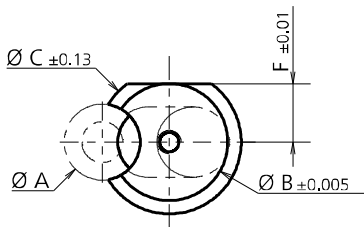

INSERT DIMENSIONS

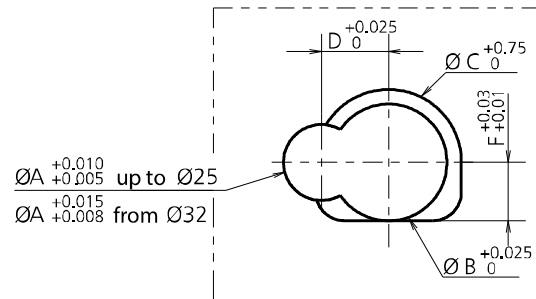
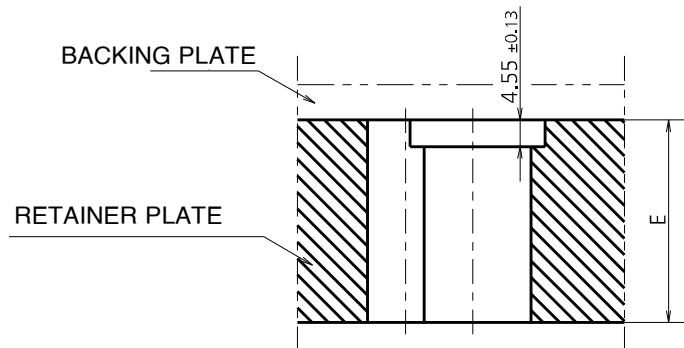

POCKET DIMENSIONS



SHOULDER PUNCH RETAINERS



TRUE SET

MRN STYLE

For Round Punches

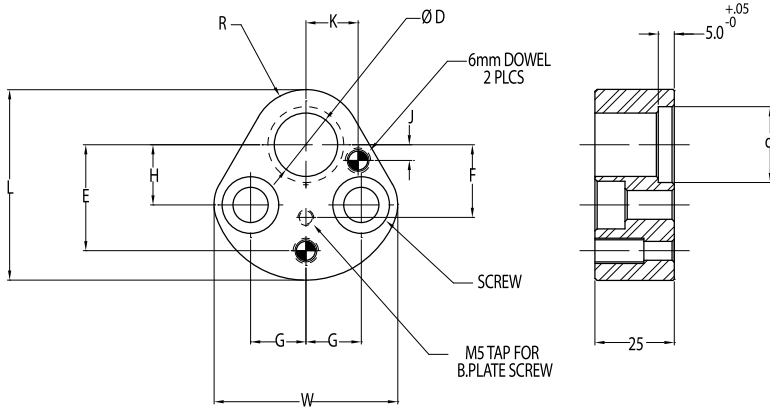

FOR ACCESSORIES AND BACKING PLATES
SEE PAGES 67.

Complete design & CAD files visit WWW.MOELLERMCAD.COM

CATALOG NUMBER	D	d1	L	W	R	H	±.01 J	±.01 K	G	±.01 E	F	SCREW SIZE
MRN 10	10	14.0	44.5	39.9	9.5	19.05	7.50	9.00	11.12	26.924	16.00	M8
MRN 13	13	17.0	50.8	48.3	12.7	19.05	6.50	12.00	14.27	29.972	16.00	M8
MRN 16	16	20.0	54.0	51.6	14.3	19.05	6.00	13.50	15.87	31.750	16.00	M8
MRN 20	20	24.0	60.3	58.2	17.5	19.05	5.00	16.50	17.47	33.528	23.00	M10
MRN 25	25	29.0	69.9	66.5	22.2	23.82	7.00	22.00	19.84	40.640	30.00	M12
MRN 32	32	36.0	69.9	66.5	22.2	23.82	7.00	22.00	19.84	40.640	30.00	M12

MRO STYLE

For Shaped Punches

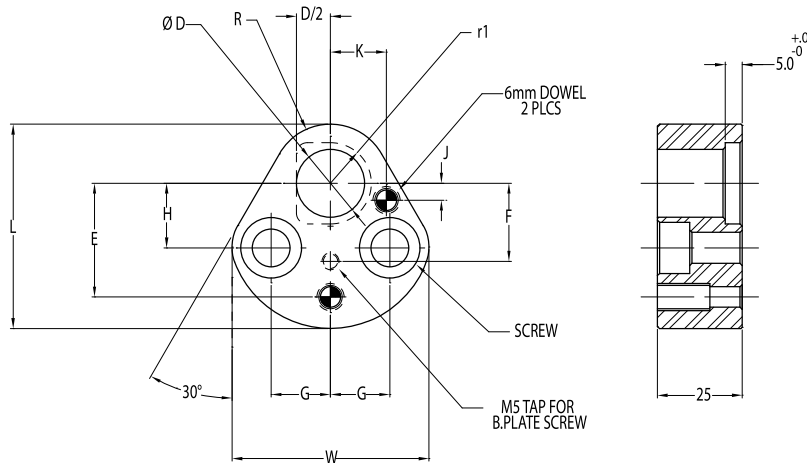

Complete design & CAD files visit WWW.MOELLERMCAD.COM

CATALOG NUMBER	D	r1	L	W	R	H	±.01 J	±.01 K	G	±.01 E	F	SCREW SIZE
MRO 10	10	7.0	44.5	39.9	9.5	19.05	7.50	9.00	11.12	26.924	16.00	M8
MRO 13	13	8.5	50.8	48.3	12.7	19.05	6.50	12.00	14.27	29.972	16.00	M8
MRO 16	16	10.0	54.0	51.6	14.3	19.05	6.00	13.50	15.87	31.750	16.00	M8
MRO 20	20	12.0	60.3	58.2	17.5	19.05	5.00	16.50	17.47	33.528	23.00	M10
MRO 25	25	14.5	69.9	66.5	22.2	23.82	7.00	22.00	19.84	40.640	30.00	M12
MRO 32	32	18.0	69.9	66.5	22.2	23.82	7.00	22.00	19.84	40.640	30.00	M12



SHOULDER PUNCH RETAINERS



TRUE SET

MRP STYLE

with Symmetrical 3rd Dowel
For Round Punches

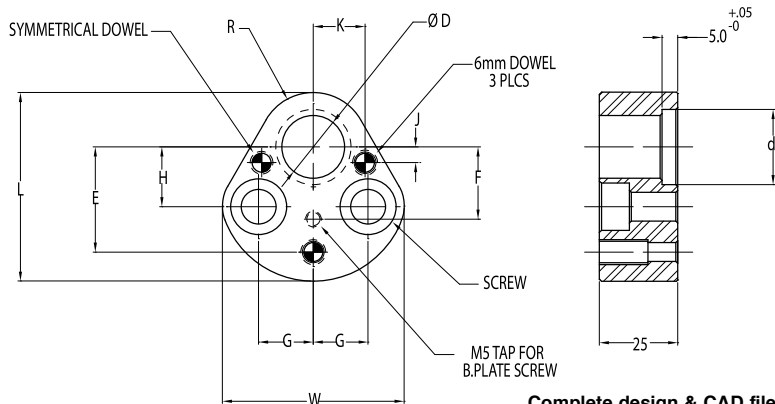

FOR ACCESSORIES AND BACKING PLATES
SEE PAGE 67.

Complete design & CAD files visit WWW.MOELLERMCAD.COM

CATALOG NUMBER	D	d1	L	W	R	H	±.01 J	±.01 K	G	±.01 E	F	SCREW SIZE
MRP 10	10	14.0	44.5	39.9	9.5	19.05	7.50	9.00	11.12	26.924	16.00	M8
MRP 13	13	17.0	50.8	48.3	12.7	19.05	6.50	12.00	14.27	29.972	16.00	M8
MRP 16	16	20.0	54.0	51.6	14.3	19.05	6.00	13.50	15.87	31.750	16.00	M8
MRP 20	20	24.0	60.3	58.2	17.5	19.05	5.00	16.50	17.47	33.528	23.00	M10
MRP 25	25	29.0	69.9	66.5	22.2	23.82	7.00	22.00	19.84	40.640	30.00	M12
MRP 32	32	36.0	69.9	66.5	22.2	23.82	7.00	22.00	19.84	40.640	30.00	M12
MRP 40	40	44.0	77.4	77.8	26.0	27.00	10.00	26.00	24.00	43.993	33.35	M12

MRQ STYLE

with Symmetrical
3rd Dowel For
Shaped
Punches

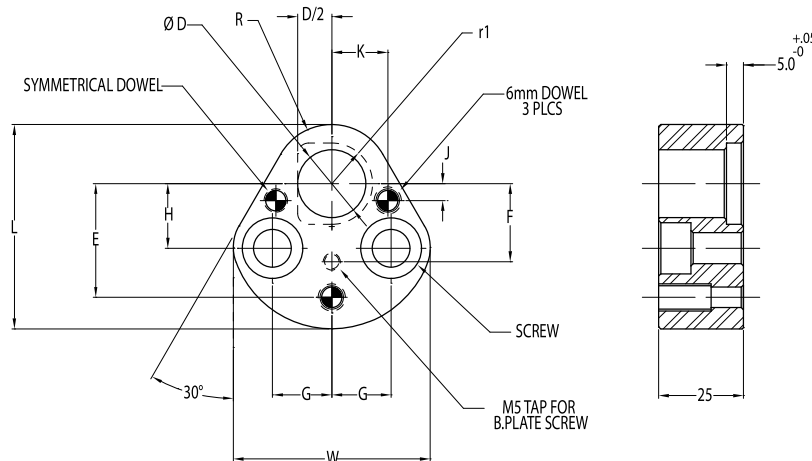

Complete design & CAD files visit WWW.MOELLERMCAD.COM

CATALOG NUMBER	D	r1	L	W	R	H	±.01 J	±.01 K	G	±.01 E	F	SCREW SIZE
MRQ 10	10	7.0	44.5	39.9	9.5	19.05	7.50	9.00	11.12	26.924	16.00	M8
MRQ 13	13	8.5	50.8	48.3	12.7	19.05	6.50	12.00	14.27	29.972	16.00	M8
MRQ 16	16	10.0	54.0	51.6	14.3	19.05	6.00	13.50	15.87	31.750	16.00	M8
MRQ 20	20	12.0	60.3	58.2	17.5	19.05	5.00	16.50	17.47	33.528	23.00	M10
MRQ 25	25	14.5	69.9	66.5	22.2	23.82	7.00	22.00	19.84	40.640	30.00	M12
MRQ 32	32	18.0	69.9	66.5	22.2	23.82	7.00	22.00	19.84	40.640	30.00	M12
MRQ 40	40	22.0	77.4	77.8	26.0	27.00	10.00	26.00	24.00	43.993	33.35	M12

XMRN STYLE For Round Punches

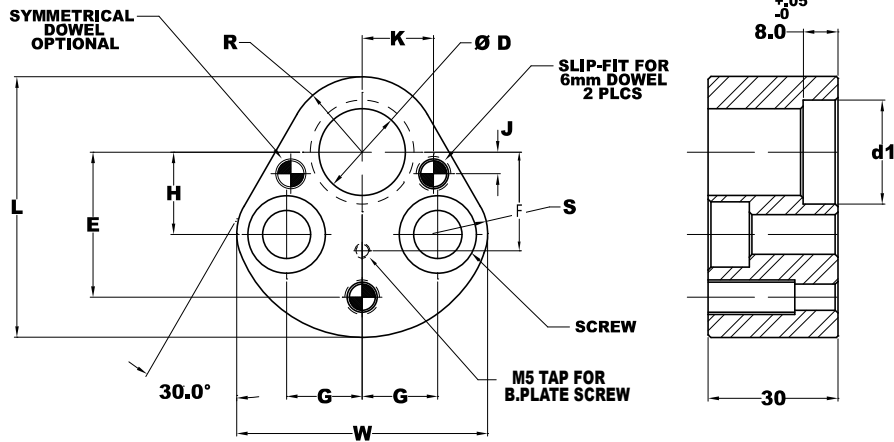

PART NUMBER	D	d1	L	W	R	H	± .01 J	± .01 K	S	G	± .01 E	SCREW SIZE
XMRN 010	10.00	15.5	44.3	39.75	9.5	19.05	7.5	9.0	12.65	11.12	26.924	M8
XMRN 013	13.00	18.5	50.67	48.13	12.7	19.05	6.5	12.0	9.47	14.27	29.972	M8
XMRN 016	16.00	21.5	53.85	51.6	14.2	19.05	6.0	13.5	9.47	15.87	31.750	M8
XMRN 020	20.00	25.5	60.2	58.0	17.4	19.05	5.0	16.5	12.62	17.47	33.528	M10
XMRN 025	25.00	30.5	69.72	66.32	22.2	23.82	7.0	22.0	22.17	19.84	40.640	M12

XMRO STYLE For Shaped Punches

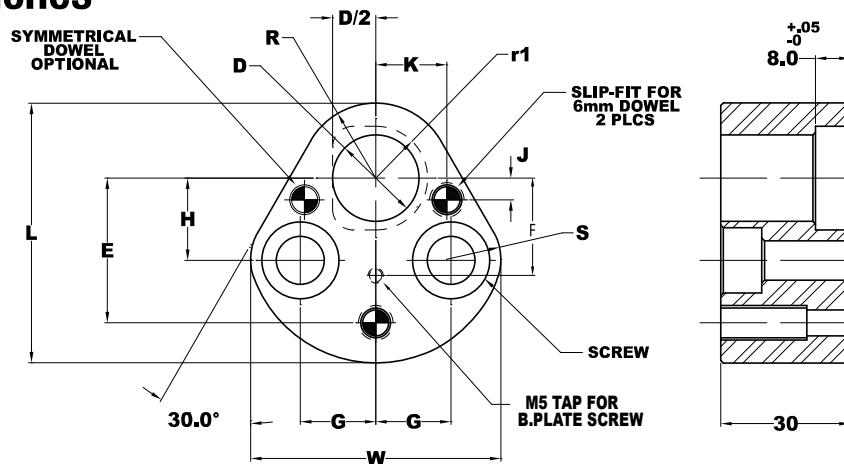

PART NUMBER	D	r1	L	W	R	H	± .01 J	± .01 K	S	G	± .01 E	SCREW SIZE
XMRO 010	10.00	7.75	44.3	39.75	9.5	19.05	7.5	9.0	12.65	11.12	26.924	M8
XMRO 013	13.00	9.25	50.67	48.13	12.7	19.05	6.5	12.0	9.47	14.27	29.972	M8
XMRO 016	16.00	10.75	53.85	51.6	14.2	19.05	6.0	13.5	14.2	15.87	31.750	M8
XMRO 020	20.00	12.75	60.2	58.0	17.4	19.05	5.0	16.5	12.62	17.47	33.528	M10
XMRO 025	25.00	15.25	69.72	66.32	22.2	23.82	7.0	22.0	22.17	19.84	40.640	M12

RETAINER & ACCESSORIES

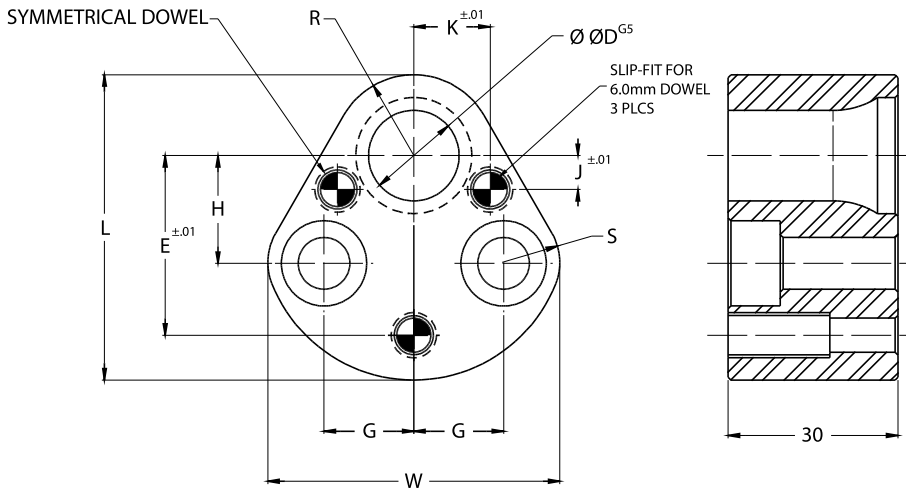

CATALOG TYPE	D	L	W	R	H	J	K	S	G	E	SCREW SIZE
XMRT 010	10	44.32	39.75	9.5	19.05	7.5	9.0	12.65	11.1	26.925	M8
XMRT 013	13	50.67	48.13	12.7	19.05	6.5	12.0	9.47	14.3	29.970	M8
XMRT 016	16	53.85	51.64	14.2	19.05	6.0	13.5	9.47	15.9	31.750	M8
XMRT 020	20	60.20	58.0	17.4	19.05	5.0	16.5	12.62	17.5	33.530	M10

TRUMPET HEAD PUNCH RETENTION SLEEVE

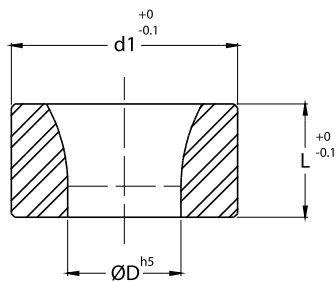

CATALOG TYPE	D	d1	L
XMAQ 005	5	9	7
XMAQ 006	6	11	7
XMAQ 008	8	13	8
XMAQ 010	10	16	9
XMAQ 013	13	19	9
XMAQ 016	16	22	9
XMAQ 020	20	27	10

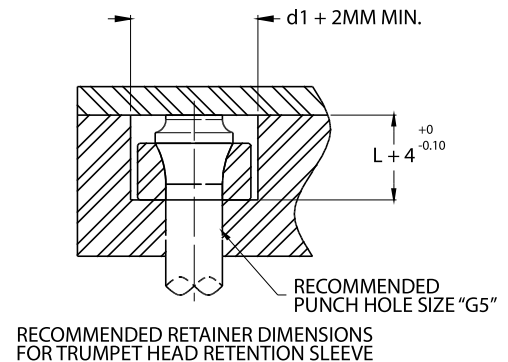

ENDMILL FOR TRUMPET HEAD RETAINERS

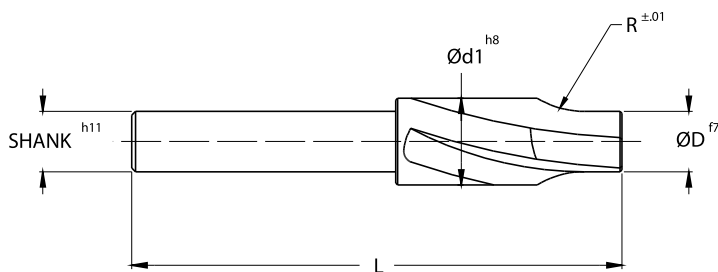

CATALOG TYPE	D	d1	R	SHANK	L
XMAK 005	5	7.4	10	7.4	71
XMAK 006	6	9.5	10	9.5	71
XMAK 008	8	11.5	12	11.5	71
XMAK 010	10	14.5	15	13	71
XMAK 013	13	17.5	15	13	71
XMAK 016	16	20.5	15	13	71
XMAK 020	20	25.5	15	16	71

RETRACTABLE RETAINERS



BALL-LOCK STYLE/HEAVY DUTY

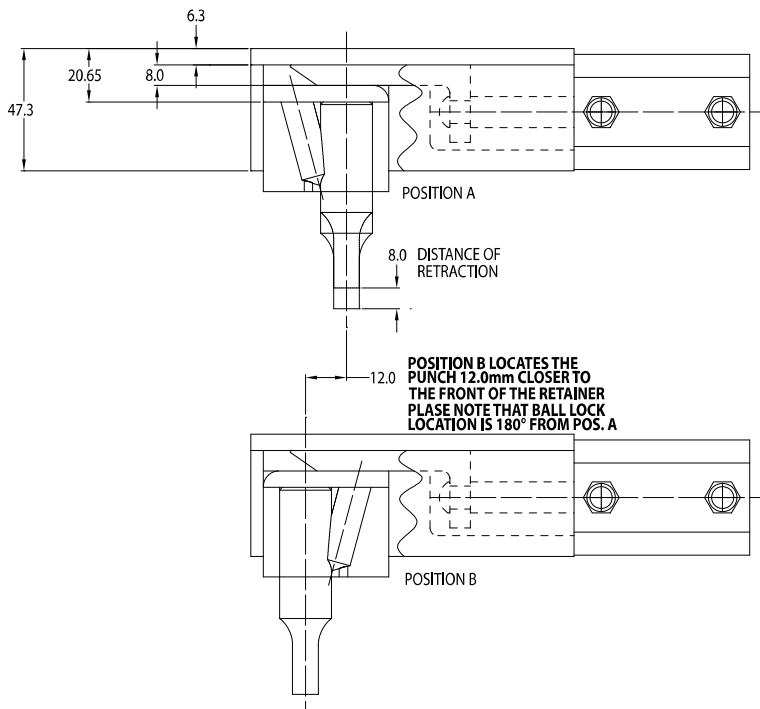
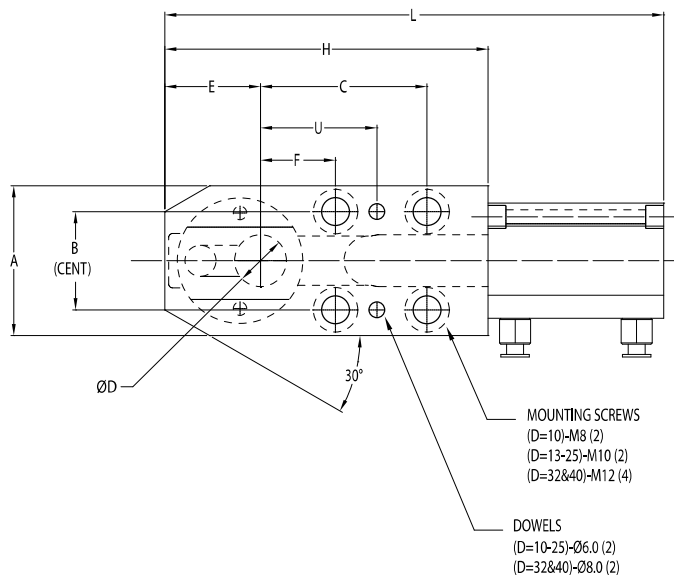

Moeller dual-position ball lock retractable retainers provide the capability to add, or subtract, holes quickly without affecting demanding production schedules, and without the added cost of additional tooling. Moeller dual-position ball lock retractable retainers are available to conform to NAAMS, and leading automotive standards. Position B facilitates close-space applications by moving the punch 12mm closer to the front end of the retainer. Moeller dual-position ball lock retainers feature a strong and convenient one-piece body, eliminating the need for a separate safety shield.

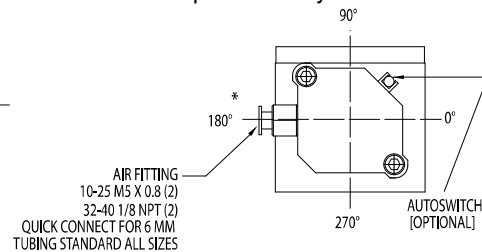

RECOMMENDED AIR PRESSURE:
4.60-5.3 kgf/cm² (65-75 PSI)

MINIMUM PRESSURE:
3.2 kgf/cm² (45 PSI)

MAXIMUM PRESSURE:
10.2 kgf/cm² (145 PSI)

NOTE:
CHANGE RETAINER SET INCLUDES ALL NECESSARY SCREWS AND DOWELS, AIR CYLINDER AND FITTINGS. TUBING FOR AIR SUPPLY AND AUTOSWITCH ARE NOT INCLUDED AND MUST BE ORDERED SEPARATELY.
CONSULT FACTORY FOR ADDITIONAL ACCESSORIES.

CATALOG NUMBER	D	L	A	±.01 B	C		E		F		H	U ±.01		SCREW SIZE
					POS.A	POS.B	POS.A	POS.B	POS.A	POS.B		POS.A	POS.B	
MRA 10	10	161	46	30			28	16	21	33	93.5	37	49	M8
MRA 13	13	172.5	50	30			28	16	25	37	100	41	53	M10
MRA 16	16	177	50	30			31	19	25	37	104.5	41	53	M10
MRA 20	20	191.5	58	38			32.5	20.5	29	41	113.5	45	57	M10
MRA 25	25	206.5	58	38			35	23	29	41	123.5	45	57	M10
MRA 32	32	260	80	56	100	112	38	26	38	50	152	60	72	M12
MRA 40	40	264	80	56	100	112	42	30	38	50	156	60	72	M12

ORDERING EXAMPLE: MRA 13, OR MRA 13 POSITION B

RETRACTABLE RETAINERS



SHOULDER STYLE

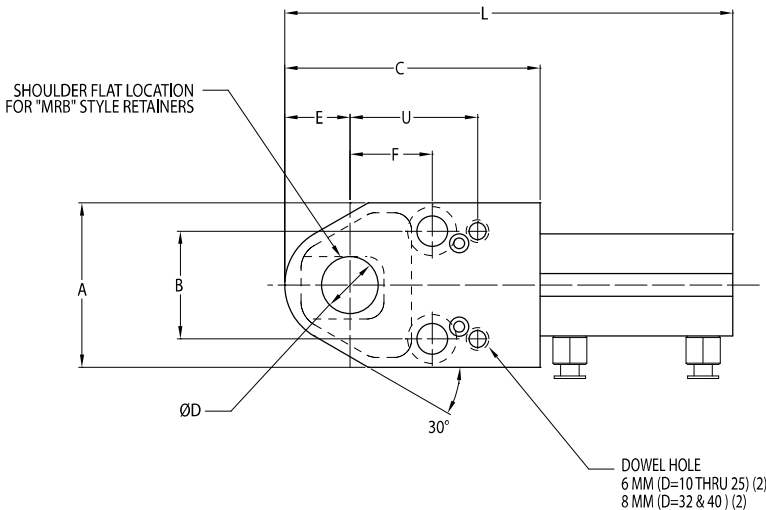

Moeller shoulder retractable retainers provide the capability to add, or subtract, holes quickly without affecting demanding production schedules, and without the added cost of additional tooling. Moeller shoulder retractable retainers feature a strong and convenient one-piece body, eliminating the need for a separate safety shield.

RECOMMENDED AIR PRESSURE:
4.60-5.3 kgf/cm² (65-75 PSI)

MINIMUM PRESSURE:
3.2 kgf/cm² (45 PSI)

MAXIMUM PRESSURE:
10.2 kgf/cm² (145 PSI)

NOTE:
CHANGE RETAINER SET INCLUDES ALL NECESSARY SCREWS AND DOWELS, AIR CYLINDER AND FITTINGS. TUBING FOR AIR SUPPLY AND AUTOSWITCH ARE NOT INCLUDED AND MUST BE ORDERED SEPARATELY. CONSULT FACTORY FOR ADDITIONAL ACCESSORIES.

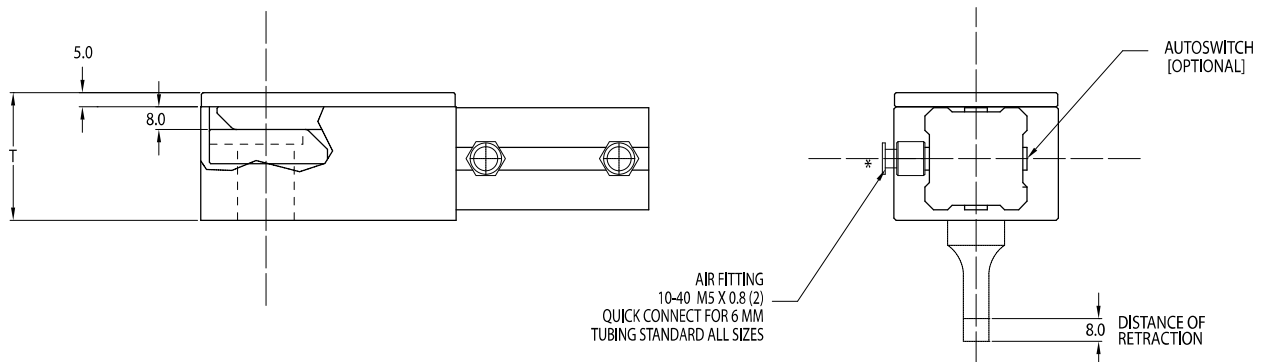

ROUND PUNCH CATALOG NUMBER	SHAPED PUNCH CATALOG NUMBER	D	L	A	±.01 B	C	E	F	T	±.01 U	SCREW SIZE
MRC 10	MRB 10	10	128	46	30	73	18	25	45	41	M8
MRC 13	MRB 13	13	128	49	30	73	18	25	45	41	M10
MRC 16	MRB 16	16	128	49	30	73	18	25	45	41	M10
MRC 20	MRB 20	20	155	58	38	90	23	29	45	45	M10
MRC 25	MRB 25	25	155	58	38	90	23	29	45	45	M10
MRC 32	MRB 32	32	208	80	56	125	33	38	55	60	M12
MRC 40	MRB 40	40	208	80	56	125	33	38	55	60	M12

ORDERING EXAMPLE: MRC 13 (FOR ROUND POINT PUNCH)
ORDERING EXAMPLE: MRB 13 (FOR SHAPED POINT PUNCHES - PLEASE NOTE FLAT LOCATION WHEN ORDERING PUNCHES)

SPECIAL MULTI HOLE

BALL-LOCK RETAINERS

Shown below are examples of the two styles of Special Multi-Hole Ball Lock Retainers offered by Moeller Precision Tool. The True Set Style is Moeller's patented one piece construction, through hardened retainer. The conventional Backing Plate Style is supplied with a hardened Backing Plate attached by fasteners to the Retainer. All Ball Lock retainer punch or button holes must be designated as Round, class "R" or Shaped, class "F". Where shaped components are being used, the angle holes are precision ground. This guarantees radial location, but adds cost to the retainer. **Note: Ball-Seat class "R" will be supplied unless otherwise specified.**

TRUE SET STYLE

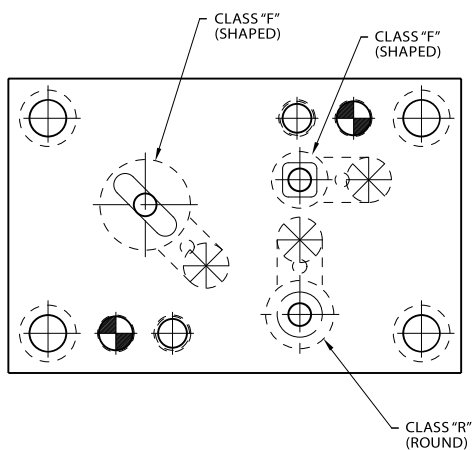

BACKING PLATE STYLE

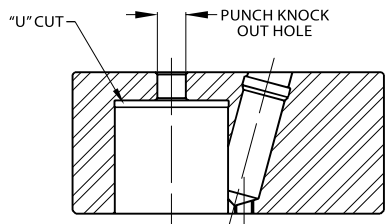
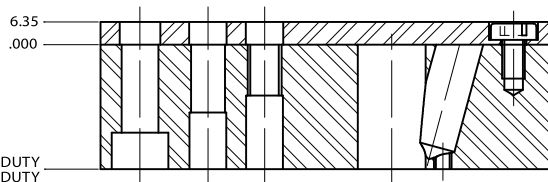
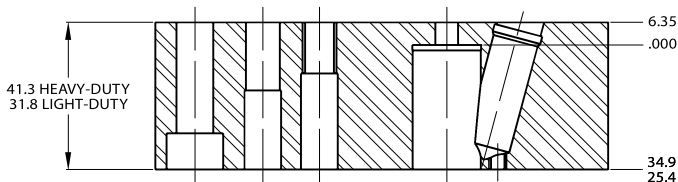
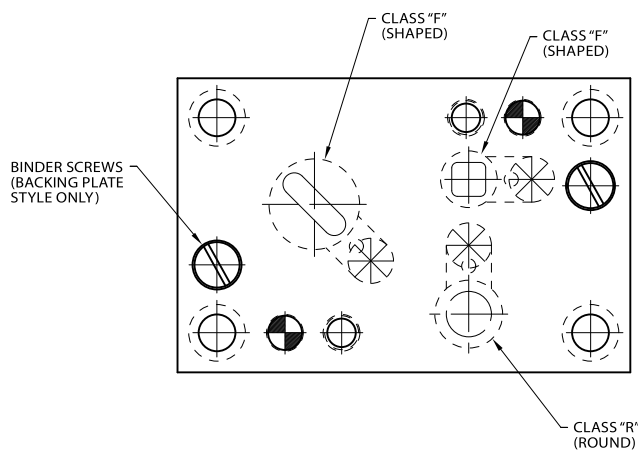

DETAIL VIEW OF PUNCH HOLE

SPECIAL FEATURES:

- *AN EXCLUSIVE PATENTED MOELLER PRODUCT PATENT NO.'s 0351395 & 5357835 INTERNATIONAL PATENT PENDING
- *ONE-PIECE CONSTRUCTION

TOLERANCES ALL TYPES

OUTSIDE EDGES	±.5
DOWEL HOLE LOCATIONS	±.01
SCREW HOLE LOCATIONS	±.1
COMPONENT HOLE LOCATIONS	±.01

CLASS	BALL-HOLES	RADIAL TOL.
R	±.5°
F	±.0°5'

MOELLER™

PRECISION TOOL



THE INDUSTRY INNOVATOR OF BALL-LOCK
PRODUCTS FOR OVER 60 YEARS

TRUE-LOCK™

Moeller's **Exclusive** True-Lock™ is the revolutionary ball-lock system re-engineered for perfect alignment and **positive locking position** between punches and retainers, guaranteed!

Groove in punch shank opposing the ball lock mates with a permanently affixed dowel pin in the retainer for correct radial location.



- Eliminates the cost of catastrophic failures
- Guarantees correct locking position
- Assures ball-lock retention
- Standard inventoried product – 2-day delivery
- Effective and adaptable to all ball-lock applications
- Eliminates the need for twist-and-lock

To Order, Simply Add Alteration Code:

TL

USA Patent Nos. D1,026,604; D1,026,983; D1,039,012 and US Patent Pending.
European Design Registered; European Patent Pending



RETAINER COMPONENTS

TRUE SET RETAINER COMPONENTS

	TRUE SET RETAINER	SOC. HD. CAP SCREW	DOWELS	BALL	SPRING	BALL RELEASE SCREW	ANGLE HOLE SET SCREW
HEAVY DUTY	MRH 10	MAC 8-45 M8 x 45	MAD 6-20 6mm x 20	MAB 10 10mm	MAS 10 (W/CLIP) MAS 10T (W/SCREW) 10mm	MAC 4-20 M4 X 20	MAN 10
	MRH 13			MAB 12 12mm	MAS 12 (W/CLIP) MAS 12T (W/SCREW) 12mm 13mm/40mm		MAN 12
	MRH 16						
	MRH 20	MAC 10-50 M10 x 50					
	MRH 25	MAC 12-50 M12 x 50					
	MRH 32						
MRH 40							
LIGHT DUTY	MRL 06	MAC 6-35 M6 X 35	MAD 3-20 3mm x 20 MAD 6-20 6mm x 20	MAB 6 6mm	MAS 6 6mm	MAC 3-15 M3 x 15	
	MRL 10	MAC 8-35 M8 x 35	MAD 6-20 6 mm x 20	MAB 8 8mm	MAS 8 8mm	MAC 4-20 M4 x 20	
	MRL 13						
	MRL 16						
	MRL 20	MAC 10-40 M10 x 40					
	MRL 25	MAC 12-40 M12 x 40					
	MRL 32						
	MRL 38						

SPECIAL BACKING PLATE RETAINER ACCESSORIES

	SPRINGS	BALLS
6 DIA.	MAS 6S	MAB 6
8 DIA.	MAS 8S	MAB 8
10 DIA.	MAS 10S	MAB 10
12 DIA.	MAS 12S	MAB 12

BOOSTER SPRINGS

	PUNCH SIZE 10 MM HDBL CATALOG # MAS010B
	PUNCH SIZE 13 THRU 40 MM HDBL CATALOG # MAS012B

ECONOMY ROUND TRUE SET RETAINER COMPONENTS

TRUE SET ROUND RETAINER	SOC. HD. CAP SCREW	DOWELS	BALL	SPRING	BALL RELEASE SCREW	ANGLE HOLE SET SCREW
MRR 10	MAC 12-50 TL M12-1.75 x 50mm	MAD 6-20 6mm X 20	MAB 10 10mm	MAS 10T 10mm	MAC 4-20 4mm X 20	MAN 10
MRR 13			MAB 12 12mm	MAS 12T 12mm		MAN 12
MRR 16						
MRR 20	MAC 16-50 TL M16-2.0x50mm					
MRR 25	MAC 20-50 TL M20-2.5x50mm					
MRR 32						
MRR 40						

SHOULDER TRUE SET RETAINER COMPONENTS

TRUE SET SHOULDER RETAINER	SOC. HD. CAP SCREW	DOWELS	TRUE SET SHOULDER RETAINER	SOC. HD. CAP SCREW	DOWELS
MRN 10	CAT#: MAC 8-35 DESC: M8x35	MAD 6-20 6mm x 20	MRO-10	CAT#: MAC 8-35 DESC: M8x35	MAD 6-20 6mm x 20
MRN 13			MRO-13		
MRN 16			MRO-16		
MRN 20	CAT#: MAC 10-40 DESC: M10x40		MRO-20	CAT#: MAC 10-40 DESC: M10x40	
MRN 25	CAT#: MAC 12-40 DESC: M12x40		MRO-25	CAT#: MAC 12-40 DESC: M12x40	
MRN 32			MRO-32		

RETAINER ACCESSORIES

TRUE SET SHIM PLATES

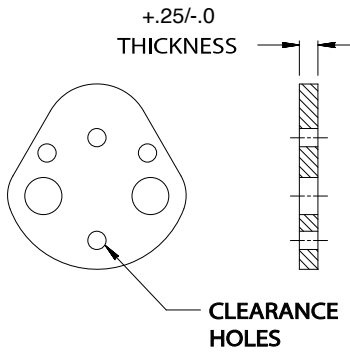

Available Thickness	Ordering Number
1.80	018
3.00	030
3.18	031
4.75	047
6.00	060
6.35	063
10.00	100
13.00	130

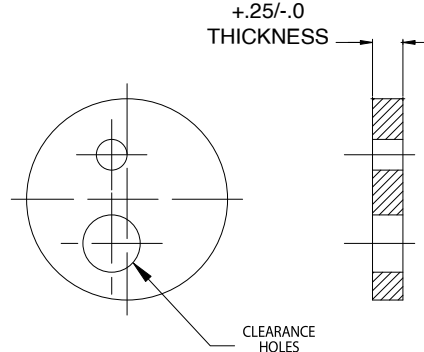

CATALOG NUMBER
MAX010-
MAX013-
MAX016-
MAX020-
MAX025-
MAX032-
MAX040-

INSERT SHIM THICKNESS

ORDERING EXAMPLE
MAX013-031

CATALOG NUMBER
MAY010-
MAY013-
MAY016-
MAY020-
MAY025-
MAY032-
MAY040-

INSERT SHIM THICKNESS

ORDERING EXAMPLE
MAY013-031

TRUE SET SHOULDER RETAINER BACKING PLATES

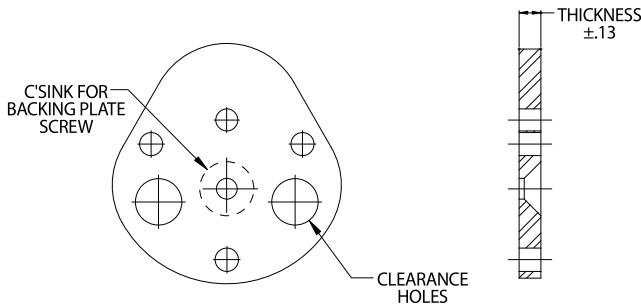

CATALOG NUMBER
MAW010-
MAW013-
MAW016-
MAW020-
MAW025-
MAW032-
MAW040-

Available Thickness	Ordering Number
4.75	047
6.35	063

HARDENED TO R/C 50-52

ORDERING EXAMPLE
MAW013-047

INSERT BACKING PLATE THICKNESS

BALL RELEASE TOOLS

ANGLE TIP
(for all Retainers)

Cat. No. MAT 01



STRAIGHT TIP
(for all Retainers)

Cat. No. MAT 02



THREADED TIP HEAVY DUTY
(for True Set Retainers) 10-40 Diameter

Cat. No. MAT 03



URETHANE STRIPPERS

CLOSED END

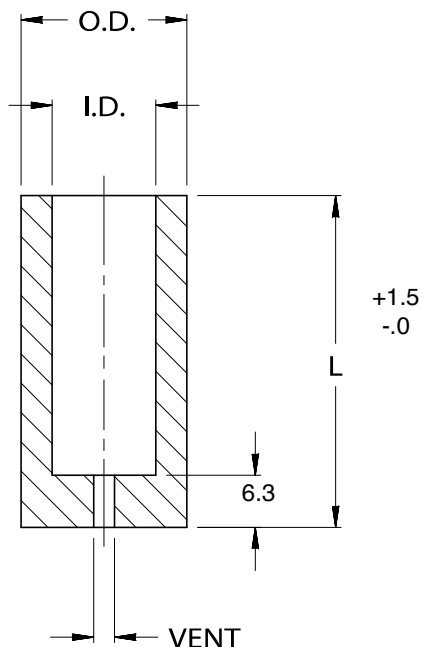

CATALOG NUMBER	I.D.	O.D.	LENGTH L	APPROXIMATE PRESSURE AVAILABLE AT DEFLECTION OF		
				3.0	6.5	9.5
MTC 06-45	06	19	45	1324	2256	—
MTC 06-53			53	1079	1863	—
MTC 06-71			71	686	1079	1765
MTC 08-45	08	21	45	1471	2207	—
MTC 08-53			53	1324	1961	2942
MTC 08-71			71	981	1618	2648
MTC 10-45	10	23	45	1716	2795	—
MTC 10-53			53	1422	2452	3187
MTC 10-56			56	1422	2452	3187
MTC 10-71			71	1128	2010	2697
MTC 13-45	13	26	45	2109	3334	—
MTC 13-53			53	1471	2354	3432
MTC 13-56			56	1471	2354	2942
MTC 13-71			71	1275	1961	2452
MTC 16-45	16	30	45	2354	3825	—
MTC 16-53			53	2158	3531	4511
MTC 16-56			56	2158	3431	4511
MTC 16-71			71	1814	2942	3825
MTC 20-45	20	38	45	2452	3923	—
MTC 20-53			53	2158	3629	5590
MTC 20-71			71	1618	2942	4658
MTC 25-45	25	50	45	9317	14318	—
MTC 25-53			53	7355	11572	15985
MTC 25-71			71	4904	8336	13485

VENT	I.D.'s
1.6	06-10
3.2	13-25

CLOSED END urethane strippers are shaped to suit the punch point by closing the die – without the material – the point and the die cavity provide the shearing action to shape the closed end.

Urethane provides an excellent balance of load bearing and memory rate, with a tensile strength of 30,250 newtons. Deflections greater than 25% are not recommended. For optimum life in high speed continuous operations, a 15% deflection is suggested.

Durometer hardness 95 Shore A.

TRUE SET STRIPPERS

- Innovative One-Piece construction
- Patented cost savings “Snap in” retention feature
- Interchangeable and complies with NAAMS standards
- Precision machined to assure perpendicularity resulting in prolonged Urethane life

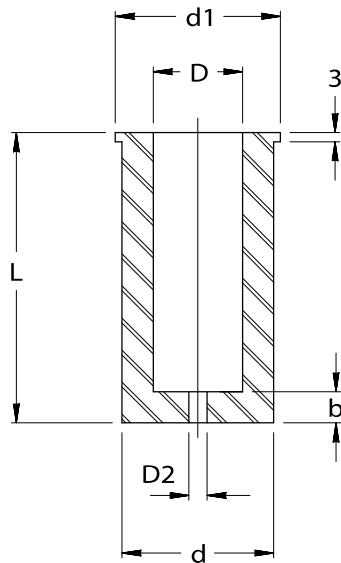
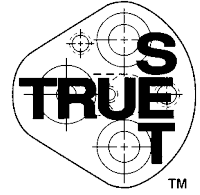

URETHANE HARDNESS 95 SHORE A

Heavy Duty Ball Lock Punch Length	Light Duty Ball Lock Punch Length	Recommended Stripper Length "L"
80	71	44
90	80	54
100	90	64
110	100	74

Moeller reserves the right to modify, correct or improve this literature or products without notice.

URETHANE STRIPPERS

Stripper Catalog Number	Punch Shank	Press Fit D	d	L	d1	d2	b
MTS10 - 44	10	9.75	18	44	21	1.6	6
MTS10 - 54	10	9.75	18	54	21	1.6	6
MTS10 - 64	10	9.75	18	64	21	1.6	6
MTS10 - 74	10	9.75	18	74	21	1.6	6
MTS13 - 44	13	12.75	23	44	26	3.0	6
MTS13 - 54	13	12.75	23	54	26	3.0	6
MTS13 - 64	13	12.75	23	64	26	3.0	6
MTS13 - 74	13	12.75	23	74	26	3.0	6
MTS16 - 44	16	15.75	28	44	31	3.0	6
MTS16 - 54	16	15.75	28	54	31	3.0	6
MTS16 - 64	16	15.75	28	64	31	3.0	6
MTS16 - 74	16	15.75	28	74	31	3.0	6
MTS20 - 44	20	19.75	33	44	36	3.0	7
MTS20 - 54	20	19.75	33	54	36	3.0	7
MTS20 - 64	20	19.75	33	64	36	3.0	7
MTS20 - 74	20	19.75	33	74	36	3.0	7
MTS25 - 44	25	24.75	40	44	43	3.0	7
MTS25 - 54	25	24.75	40	54	43	3.0	7
MTS25 - 64	25	24.75	40	64	43	3.0	7
MTS25 - 74	25	24.75	40	74	43	3.0	7
MTS32 - 44	32	31.70	50	44	55	3.0	7
MTS32 - 54	32	31.70	50	54	55	3.0	7
MTS32 - 64	32	31.70	50	64	55	3.0	7
MTS32 - 74	32	31.70	50	74	55	3.0	7
MTS40 - 44	40	39.70	60	44	65	3.0	8
MTS40 - 54	40	39.70	60	54	65	3.0	8
MTS40 - 64	40	39.70	60	64	65	3.0	8

TRUE SET STRIPPER RETAINERS



- Innovative One-Piece construction
- Patented cost savings “Snap in” retention feature
- Interchangeable and complies with NAAMS standards
- Precision machined to assure perpendicularity resulting in prolonged Urethane life
- Adaptable to special multi-hole Retainers



MTR STYLE STRIPPER RETAINER

(To be used with Standard MRH True Set Retainer)

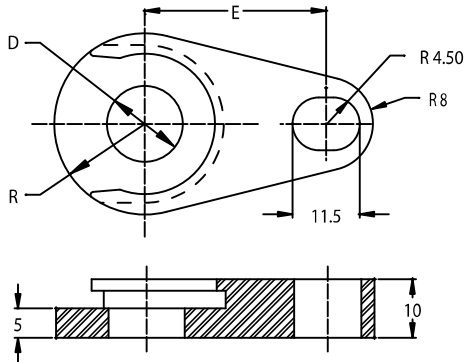

Catalog No.	D	R	E
MTR 10	10	13	28
MTR 13	13	15.5	31
MTR 16	16	18	32.9
MTR 20	20	20.5	34.8
MTR 25	25	24	39.8
MTR 32	32	31	41.3
MTR 40	40	36	45

MTP STYLE STRIPPER RETAINER

(To be used with the Round MRR True Set Retainer)

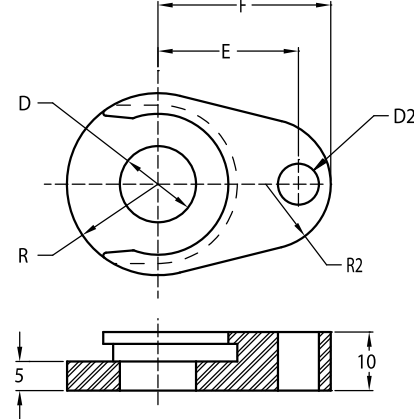

Catalog No.	D	R	E	F	D2	R2
MTP 10	10	13.0	21.0	26.5	7	10.0
MTP 13	13	15.5	23.9	29.4	7	11.0
MTP 16	16	18.0	24.5	30.0	7	12.8
MTP 20	20	20.5	29.0	36.0	9	11.8
MTP 25	25	24.0	33.5	40.5	9	12.9
MTP 32	32	31.0	40.6	49.3	9	8.0
MTP 40	40	36.0	44.0	53.0	9	8.0

MTM STYLE STRIPPER RETAINER

(To be used with MRM and Multi Hole Retainer)

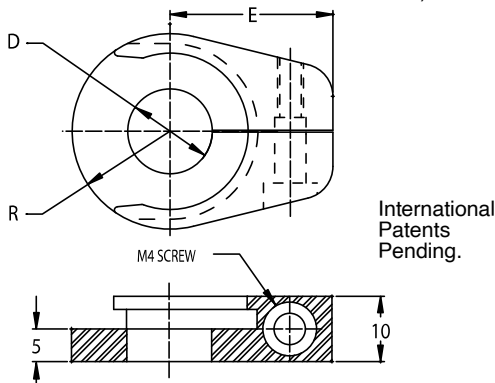

International Patents Pending.

Catalog No.	D	R	E
MTM 10	10	13	22.5
MTM 13	13	15.5	25
MTM 16	16	18	27.5
MTM 20	20	20.5	30
MTM 25	25	24	35.5
MTM 32	32	31	37.5
MTM 40	40	36	42.3

U.S. Patent No. 7,707,919B1 International Patents Pending.

NOSE LARGE STRIPPER RETAINERS



- Patented cost savings “Snap in” retention feature
- Interchangeable and complies with NAAMS standards
- Precision machined to assure perpendicularity resulting in prolonged Urethane life

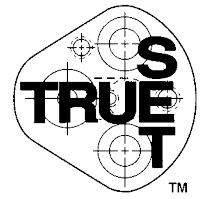

NOSE LARGE STRIPPER RETAINER

(To be used with the Standard MRH True Set Retainer)

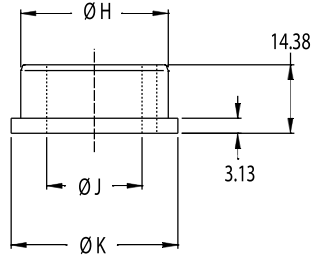
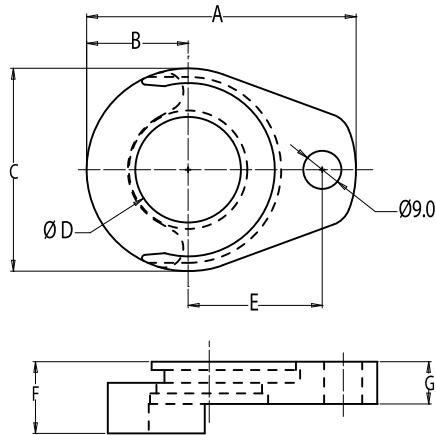

U.S. Patent No. 7,707,919B1 International Patents Pending.
*XX = “L” DIMENSION OF URETHANE

CATALOG NUMBER	SHANK Ø	MAX P/G	A	B	C	D	E	F	G	H	J	K	*USE WITH URETHANE
MTB010016	10.0	15.75	53.18	18.0	36	16	26.93	17	10	15.75	10	19	MTS16-XX
MTB013020	13.0	19.75	58.60	20.5	41	20	29.97	17	10	19.75	13	23	MTS20-XX
MTB016025	16.0	24.75	63.75	24.0	48	25	31.75	17	10	24.75	16	28	MTS25-XX
MTB020032	20.0	31.75	73.86	31.0	62	32	33.53	17	10	31.70	20	34	MTS32-XX
MTB025040	25.0	39.75	83.63	36.0	72	40	40.64	17	10	39.70	25	44	MTS40-XX
MTB032040	32.0	39.75	83.63	36.0	72	40	40.64	18	10	39.70	32	44	MTS40-XX

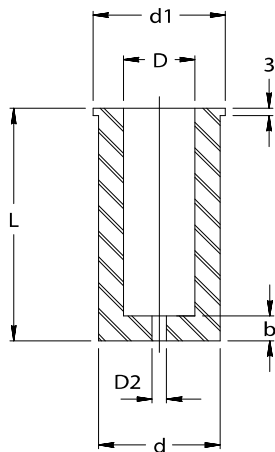

**URETHANE HARDNESS
95 SHORE A**

Heavy Duty Ball Lock Punch Length	Recommended Stripper Length “L”
80	44
90	54
100	64

NOTE: THE FOLLOWING CHART DENOTES THE REQUIRED URETHANE FOR CORRESPONDING STRIPPER RETAINER ABOVE.

CATALOG NUMBER	SHANK Ø	L +1.0/-0.6 STRIPPER LENGTHS	D	d1	d	b	D2
*MTS16-XX TO BE USE ON MTB010016	10.0	44	15.75	31	28	6	3
		54					
		64					
*MTS20-XX TO BE USE ON MTB013020	13.0	44	19.75	36	33	7	3
		54					
		64					
*MTS25-XX TO BE USE ON MTB016025	16.0	44	24.75	43	40	7	3
		54					
		64					
*MTS32-XX TO BE USE ON MTB020032	20.0	44	31.7	55	50	7	3
		54					
		64					
*MTS40-XX TO BE USE ON MTB025040	25.0	44	39.7	65	60	8	3
		54					
		64					
*MTS40-XX TO BE USE ON MTB032040	32.0	44	39.7	65	60	8	3
		54					
		64					

SPECIAL TOOLING

RELOCATION BUSHINGS

- Relocate Die Buttons up to 5mm eliminating the need of plugging or welding existing hole.
- Maintain the use of pre-existing Die Buttons.
- Cost effective method to relocate a Dowel Location.

FOR 6MM
DOWEL
TYP 3 PLCS.

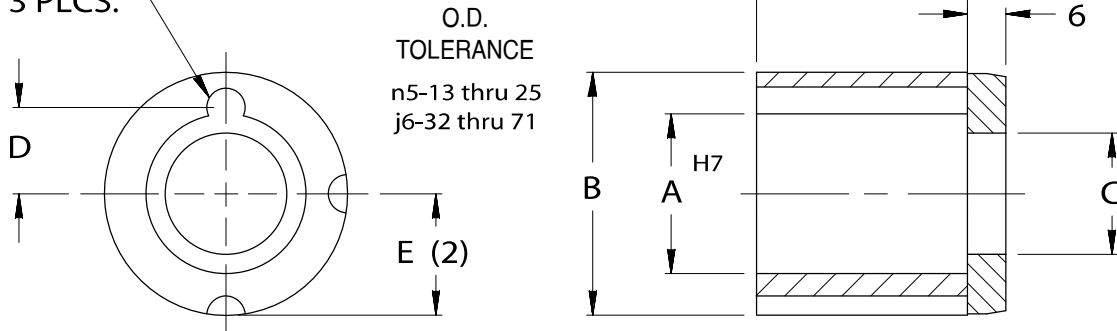

CATALOG NUMBER	A	B	C	D	E
MAR 13	13	25	9	8.2	13.5
MAR 16	16	32	10	9.0	16.0
MAR 20	20	32	14	11.0	16.0
MAR 25	25	38	19	13.5	19.0
MAR 32	32	45	26	16.0	22.5
MAR 38	38	50	32	19.0	25.0
MAR 45	45	56	39	22.5	28.0
MAR 50	50	63	44	25.0	31.5
MAR 56	56	71	50	28.0	35.5
MAR 63	63	82	57	31.5	41.0
MAR 71	71	89	65	35.5	44.5

EJECTOR COMPONENTS



PUNCH EJECTOR COMPONENTS

Ejector Punch Dimensional Specifications

SHANK DIA. D	EJECTOR SPECIFICATION	DRILL PIN HOLE	SIZE SPRING HOLE	SCREW SIZE	CROSS HOLE SIZE	PIN EXTENSION
5.0 SHOULDER	MAE 2	.64	2.18	M2.6	.81	.81 \pm .25
6.0 ALL	MAE 3	.79	2.64	M3	.81	.81 \pm .25
8.0 SHOULDER 10.0 BALL-LOCK	MAE 4	1.17	3.45	M4	1.57	1.57 \pm .38
10.0 SHOULDER 13.0 ALL 16.0 BALL-LOCK	MAE 5	1.58	4.37	M5	1.57	1.57 \pm .38
16.0 SHOULDER 20.0 ALL 25.0 ALL 32.0 ALL 40.0 ALL	MAE 6	2.36	5.18	M6	1.57 — —	1.57 \pm .38
CONSULT FACTORY	MAE 12	3.18	7.13	M8 X 1.25	—	

Ejector Component Specifications

PART DESCRIPTION	SPEC. DESCRIPTION	MAE 2	MAE 3	MAE 4	MAE 5	MAE 6	MAE 12
SET SCREW	THREAD SIZE "T"	M2.6	M3	M4	M5	M6	M8
	LENGTH "L"	5.0	5.0	5.0	5.0	6.0	6.0
SPRING	DIAMETER "D" $\begin{matrix} +.0 \\ -.25 \end{matrix}$	1.98	2.38	3.30	4.16	5.05	6.86
	FREE-LENGTH "F" $\begin{matrix} +1.5 \\ -0 \end{matrix}$	60.4	60.4	81.0	81.0	81.0	81.0
	PRESSURE (3.0 PRE-LOAD)	2.22	3.34	4.45	6.67	8.9	8.9
PIN	BODY DIAMETER "N" \pm .025	.48	.69	1.04	1.47	2.26	3.05
	LENGTH "L" $\begin{matrix} +1.5 \\ -0 \end{matrix}$	35.0	35.0	49.3	49.3	63.5	76.20
	HEAD DIAMETER "H" \pm .025	1.20	1.98	2.39	3.18	4.01	4.75
	HEAD THICKNESS "T" \pm .13	.81	1.17	1.57	1.57	2.39	2.39

CATALOG NUMBERS			
ASSEMBLY	PIN	SPRING	SCREW
MAE 2	MAE 2P	MAE 2S	MAE 2C
MAE 3	MAE 3P	MAE 3S	MAE 3C
MAE 4	MAE 4P	MAE 4S	MAE 4C
MAE 5	MAE 5P	MAE 5S	MAE 5C
MAE 6	MAE 6P	MAE 6S	MAE 6C
MAE 12	MAE 12P	MAE 12S	MAE 12C

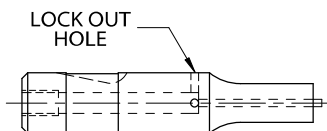

Note: Not available on shank diameters of 32mm and above, shoulder and ball lock.

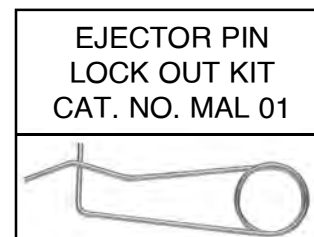

Set includes 12 pcs. of each size.

LOCATING DEVICES

STANDARD LOCATION

Standard ballseat location for all ball lock products is 90°. Standard flat, dowel groove and Windsor Lock location is at 0°. Note: 0° is at 3:00. Alternate no charge locations are 0°, 90°, 180°, 270° (see drawing). To order alternate locations specify locating device type @ ___°.

Ball lock punch example: MHR 13-08 P=6.0 W=5.5 B/S @ 0°
Button flat example: MDO25-32 P=13.0 W=10.5 F1@90°

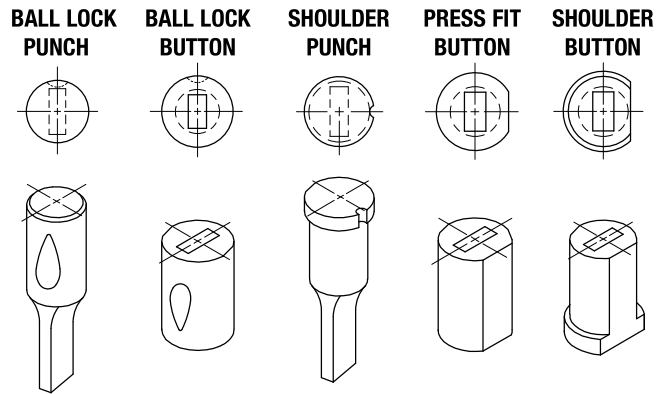

CUSTOM LOCATIONS

Any locating device can be radially positioned by specifying the appropriate device and it's desired angle. The appropriate angle is defined by a counter clockwise rotation from 0°.

Note: Parts are viewed in die position looking from above the die. Punches are viewed looking through the shanks. Buttons are viewed through top face.

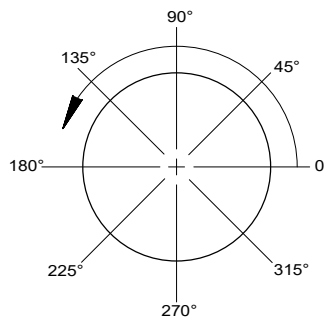

TYPICAL EXAMPLES:

CUSTOM BALL SEAT LOCATION PUNCH

BS@45°

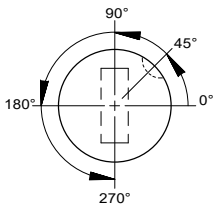

CUSTOM FLAT LOCATION DIE BUTTON

F2@105°

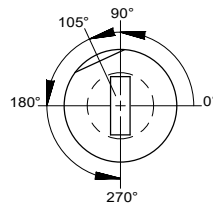

WINDSOR LOCK

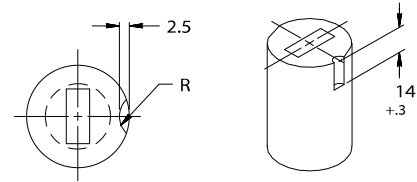

W6

6.0 WINDSOR LOCK R = 3.0 RAD

W10

10.0 WINDSOR LOCK R = 5.0 RAD

W13

13.0 WINDSOR LOCK R = 6.5 RAD

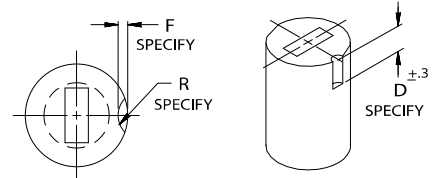

WX

USER DEFINED - Must specify "F", "R" and "D" dimensions

BUTTON RETENTION KEY

MAK-01

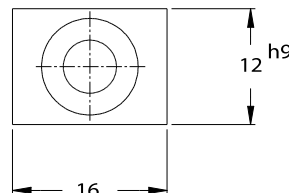
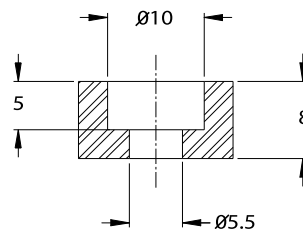

LOCATING DEVICES

FLATS ON SHOULDER PRODUCTS

F1, F5 are ground flush to shank. F6 is a user defined flat and requires an "F" dimension specified with order. F5 flats are standard 180° apart.

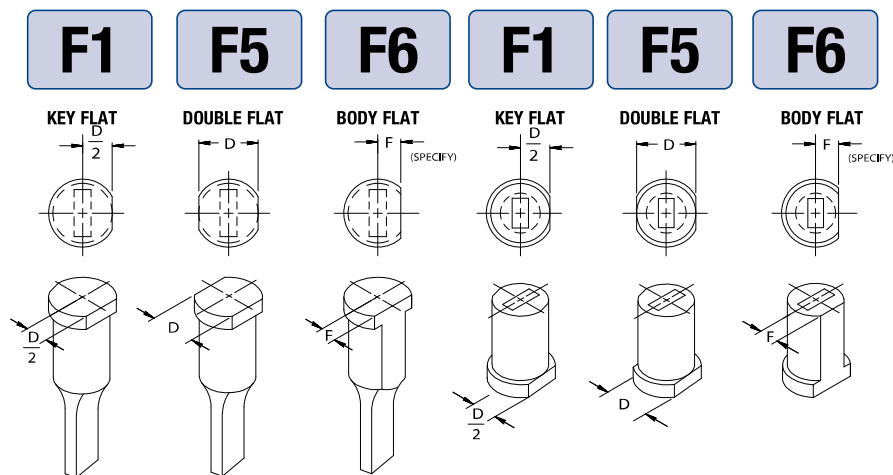

FLATS ON PRESS FIT BUTTONS

F1 uses "F" dimension as defined in chart, unless an alternate "F" dimension is specified with order. F2, F3 use "F" dimensions as defined in chart. F4, FX are user defined flats and requires "F" and "U" dimension specified with order.

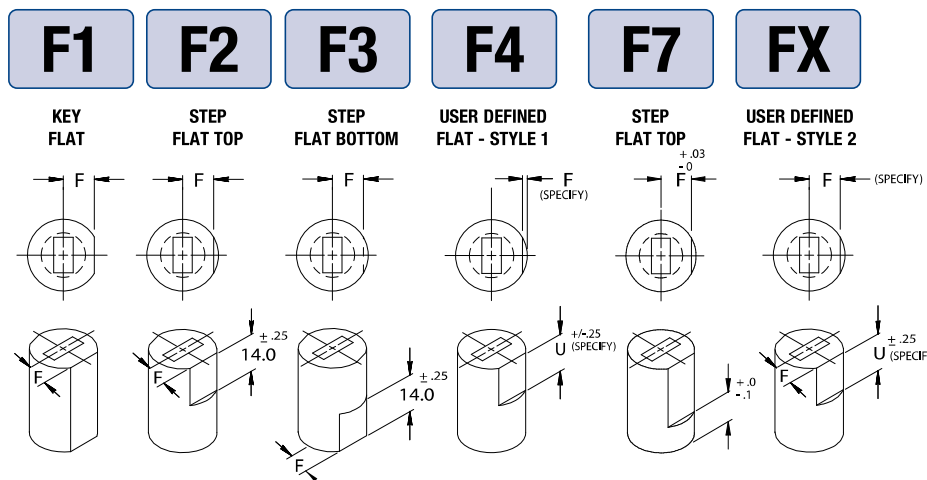

BODY DIA	F1, F2, F3		F7	
	"F" +0.02 -0.00	F	F	H
8	3.5			
10	4.0			
13	5.5	5.0	9	
16	7.0	6.5	9	
20	8.5	8.5	9	
22	9.5			
25	11.0	10.5	16	
32	14.0	14.0	16	
38	17.0			
40	18.0	18.0	16	
45	20.5			
50	23.0	23.0	16	
56	26.0			
63	29.5	29.5	16	
71	33.5			
76	35.5			
85	40.0			
90	42.5			
100	47.5			

DOWEL GROOVES

D3, D4, D6

D3, D4, D6 are standard 3, 4, 6, dowel grooves. On shoulder products, the groove is positioned tangent to shank. On all other products the dowel is ground to an "F" dimension as shown on chart. DX is a user defined dowel groove and requires an "F" dimension and dowel size specified with the order.

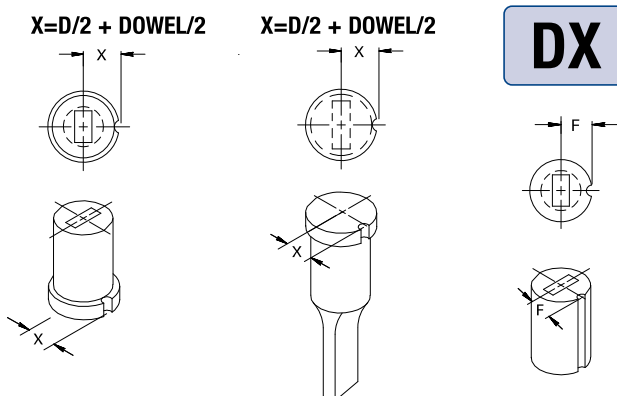

BODY DIAMETER "D"	DX SPECIFY DOWEL	D3 3.0 DOWEL	D4 4.0 DOWEL	D6 6.0 DOWEL
	"F" DIM	"F" DIM	"F" DIM	"F" DIM
8	SPECIFY	4.7	5.2	6.2
10	SPECIFY	5.5	6.0	7.0
13	SPECIFY	6.7	7.2	8.2
16	SPECIFY	8.0	8.0	9.0
20	SPECIFY	10.0	10.0	11.0
22	SPECIFY	11.0	11.0	12.0
25	SPECIFY	12.5	12.5	13.5
32-UP	SPECIFY	D/2	D/2	D/2

X/F DIMS. + / -0.13

PRODUCT ALTERATIONS

XP

OUT OF RANGE PUNCH POINT

Point "P" or "W" dimensions below catalog standard. The minimums (see charts) apply to standard catalog point lengths and overall lengths. Extended B lengths and reduced overall lengths do not apply.

XW

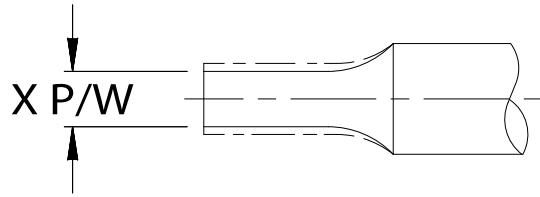

BALL LOCK AND SHOULDER PUNCHES SOLID

MAX S.B.R

SHANK D	MIN P ROUNDS		
	13	19	25
4	1.20		
5	1.30	1.30	
6	1.40	1.40	1.40
8	1.70	1.70	1.70
10	2.00	2.00	2.00
13	2.50	2.50	2.50
16	3.50	3.50	3.50
20	5.00	5.00	5.00
25	8.00	8.00	8.00
32	12.00	12.00	12.00
40	16.00	16.00	16.00
45	18.00	18.00	18.00
50	23.00	23.00	23.00
56	28.00	28.00	28.00
63	33.00	33.00	33.00

MAX S.B.R

SHANK D	MIN W SHAPES		
	13	19	25
4	1.20		
5	1.30	1.30	
6	1.40	1.40	
8	1.70	1.70	1.70
10	2.00	2.00	2.00
13	2.50	2.50	2.50
16	3.50	3.50	3.50
20	4.50	4.50	4.50
25	4.50	4.50	4.50
32	5.00	5.00	5.00
40	6.00	6.00	6.00
45	6.00	6.00	6.00
50	8.00	8.00	8.00
56	9.00	9.00	9.00
63	10.00	10.00	10.00

LIGHT DUTY EJECTOR PUNCHES

MAX S.B.R

SHANK D	MIN P ROUNDS		
	13 63.0 MIN O.A.L.	19 63.0 MIN O.A.L.	25 71.0 MIN O.A.L.
6	2.00		
10	2.70	2.70	
13	3.20	3.20	3.20
16	3.50	3.50	3.50
20	5.00	5.00	5.00
25	8.00	8.00	8.00

MAX S.B.R

SHANK D	MIN W SHAPES		
	13 63.0 MIN O.A.L.	19 63.0 MIN O.A.L.	25 71.0 MIN O.A.L.
6	2.00		
10	2.70	2.70	
13	3.20	3.20	3.20
16	3.50	3.50	3.50
20	4.00	4.00	4.00
25	5.00	5.00	5.00

HEAVY DUTY EJECTOR PUNCHES

MAX S.B.R

SHANK D	MIN P ROUNDS		
	13 63.0 MIN O.A.L.	19 63.0 MIN O.A.L.	25 71.0 MIN O.A.L.
10	2.70	2.70	
13	3.20	3.20	3.20
16	3.50	3.50	3.50
20	5.00	5.00	5.00
25	8.00	8.00	8.00
32	12.00	12.00	12.00
40	16.00	16.00	16.00

MAX S.B.R

SHANK D	MIN W SHAPES		
	13 63.0 MIN O.A.L.	19 63.0 MIN O.A.L.	25 71.0 MIN O.A.L.
10	2.50	2.50	
13	3.20	3.20	3.20
16	3.50	3.50	3.50
20	4.00	4.00	4.00
25	5.00	5.00	5.00
32	6.00	6.00	6.00
40	8.00	8.00	8.00

SHOULDER EJECTOR PUNCHES

MAX S.B.R

SHANK D	MIN P ROUNDS		
	13 63.0 MIN O.A.L.	19 63.0 MIN O.A.L.	25 71.0 MN O.A.L.
5	1.60		
6	2.00		
8	3.00	3.00	
10	3.20	3.20	3.20
13	3.20	3.20	3.20
16	4.00	4.00	4.00
20	4.00	4.00	4.00
25	5.00	5.00	5.00
32	6.00	6.00	6.00
40	8.00	8.00	8.00
45	18.00	18.00	18.00
50	23.00	23.00	23.00
56	28.00	28.00	28.00
63	33.00	33.00	33.00

MAX S.B.R

SHANK D	MIN W SHAPES		
	13 63.0 MIN O.A.L.	19 63.0 MIN O.A.L.	25 71.0 MN O.A.L.
5	1.60		
6	2.00		
8	3.00	3.00	
10	3.20	3.20	3.20
13	3.20	3.20	3.20
16	4.00	4.00	4.00
20	4.00	4.00	4.00
25	4.50	4.50	4.50
32	5.00	5.00	5.00
40	6.00	6.00	6.00
45	6.00	6.00	6.00
50	8.00	8.00	8.00
56	9.00	9.00	9.00
63	10.00	10.00	10.00

PRODUCT ALTERATIONS

XP OUT OF RANGE BUTTON DIMENSIONS

Hole "P" or W" dimension above or below catalog standard range (see charts) available on Ultra Life style button only.

XW

PRESS FIT ULTRA LIFE TAPER RELIEF

CATALOG TYPE	MIN P	MIN W	MAX P/G
MU 08	1.50	1.50	3.60
MU 10	1.60	1.60	5.80
MU 13	1.80	1.80	8.00
MU 16	2.50	2.50	10.00
MU 20	2.80	2.80	13.00
MU 22	3.10	3.10	16.00
MU 25	3.20	3.20	18.50
MU 32	3.20	3.20	22.00
MU 38	3.20	3.20	29.00
MU 40	3.20	3.20	30.00
MU 45	3.20	3.20	34.00
MU 50	3.20	3.20	37.00
MU 56	3.20	3.20	41.00
MU 63	3.20	3.20	47.00
MU 71	3.20	3.20	52.00
MU 76	3.20	3.20	56.00
MU 85	3.20	3.20	62.00
MU 90	3.20	3.20	65.00
MU_100	3.20	3.20	73.00

SHOULDER ULTRA LIFE TAPER RELIEF

CATALOG TYPE	MIN P	MIN W	MAX P/G
MM 08	1.50	1.50	3.60
MM 10	1.60	1.60	5.80
MM 13	1.80	1.80	8.00
MM 16	2.50	2.50	10.00
MM 20	2.80	2.80	13.00
MM 22	3.10	3.10	16.00
MM 25	3.20	3.20	18.50
MM 32	3.20	3.20	22.00
MM 38	3.20	3.20	29.00
MM 40	3.20	3.20	30.00
MM 45	3.20	3.20	34.00

XS

SLUG CONTROL ALTERATION

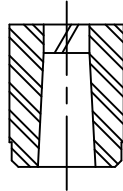

NOTE: Advise material thickness and die clearance, per side at time of order.

XR

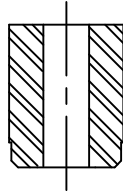

Button round or shape/I.D. through hole no relief

ALTERED POINT LENGTH OR LAND DIMENSION

This is a customer specific alteration and a dimension must be supplied.

XBR

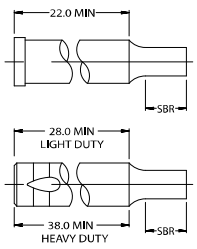

XB

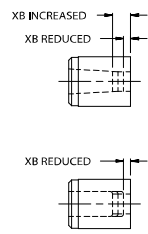

AE

AIR EJECTOR APPLICATION

Filled cross pin hole with no ejector components.

W1 WHISTLE NOTCH PUNCHES

NOTE: For light-duty punches only

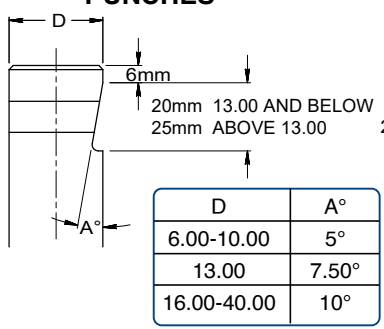

BUTTONS

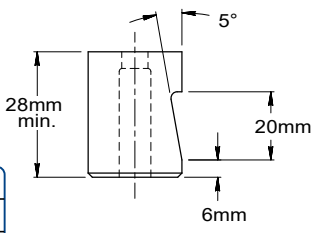

SR

OPEN IN-LINE DOWEL FOR SLUG RELIEF

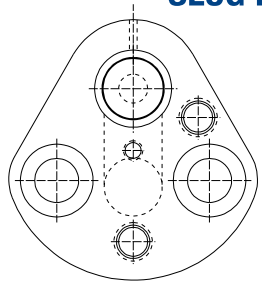

CD CENTER DOWEL

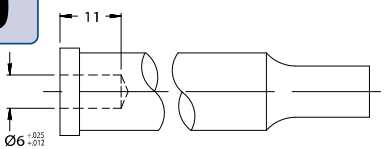

NOTE: SEE PAGES 28-30 FOR CENTER DOWEL PRODUCTS. Available on all length shoulder punches in diameters of 10mm through 40mm. Available on 70mm or longer ejector style shoulder punches in diameters of 10mm through 40mm.

SD SYMMETRICAL RETAINER DOWEL

GB BALL SEAT

BALL SEAT GRIND CHARGE

NOTE: Specify a radial location if a double ballseat is required.

PRODUCT ALTERATIONS

OVERALL LENGTH REDUCTIONS

Reduces punch or button length maintaining "B" point or land length. Not available in counter bore style on shoulder or ball lock buttons.

X1

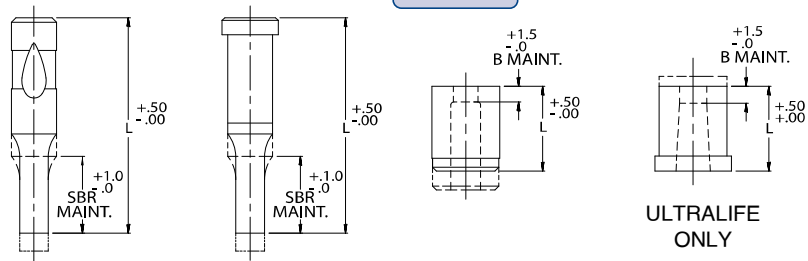

X2

Reduces punch or button length but also reduces "B" dimension or land length.

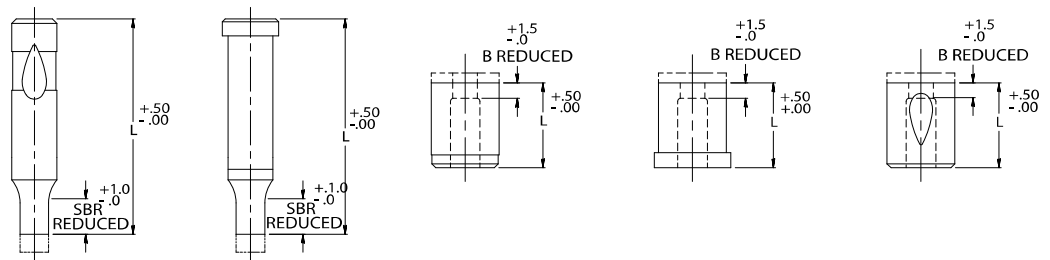

X3

Provides a precision overall length of +/- .02

Note: .5 maximum stock removal

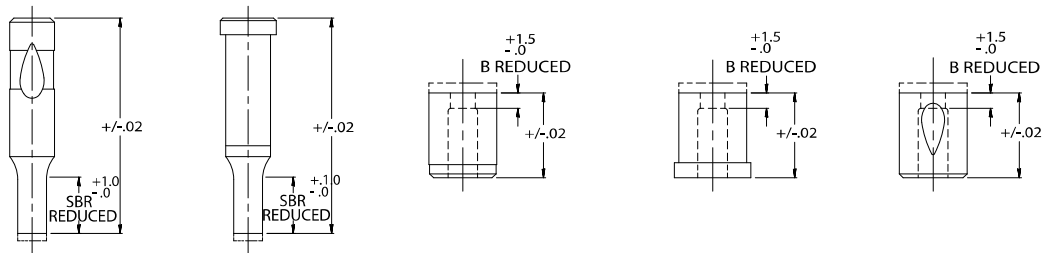

HEAD ALTERATIONS

X4

Provides a precision head length but reduces overall length

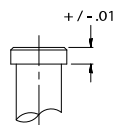

X5

Reduces head length but reduces overall length

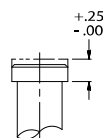

X6

Reduces head length while maintaining overall length

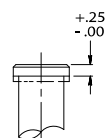

X7

Reduces head diameter

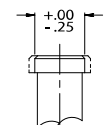

X8

Angle on head face to improve strength

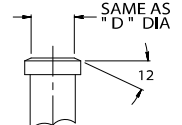

PRODUCT ALTERATIONS

CROSS PIN ALTERATION

XCP



To add a Cross Pin Hole
Use alteration code XCP at end of description

Example: MEC 016-100
P=15.3 XCP

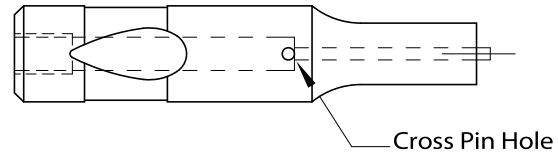

XD

REDUCTION OF SHANK DIMENSION

Reduce shank to customer specific size. Does not alter head diameter.

Example: MDO 20-32
P=10.0, W=5.0, XD=19.0

BODY	5	6	8	10	13	16	20	22	25	32	38	40
PUNCH SOLID MIN D	3.5	5.0	6.5	8.5	11.5	14.5	18.5		23.5	30.5		38.5
PUNCH EJECTOR MIN D	4.5	5.0	6.8	9.0	11.5	14.5	18.5		23.5	30.5		38.5
BUTTON MIN D			6.5	8.5	11.5	14.5	18.5	20.5	23.0	30.0	36.0	38.0

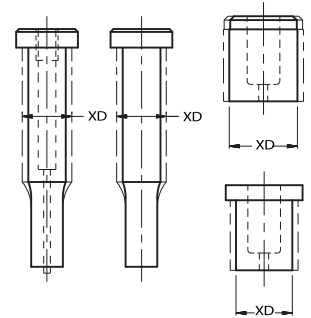

EXTRUSION TOOLS

How precise L1 and E dimensions need to be is application specific. Please specify tolerance with order.

For a precision "L" dimension add alteration code X3.

For strength, all extrusion buttons are produced in the "Ultralife" style.

E1

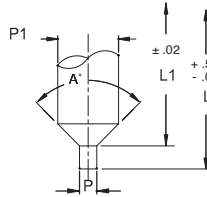

E2

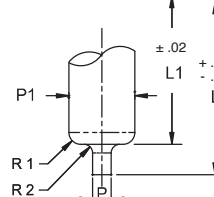

E3

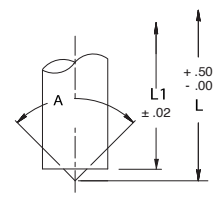

E4

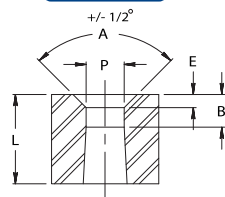

E5

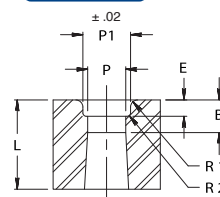

E6

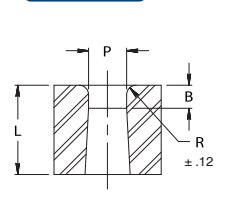

E7

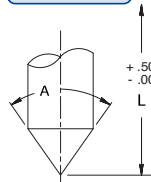

E8

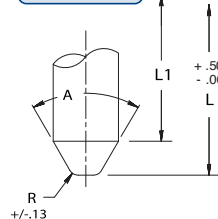

E9

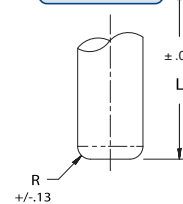

E10

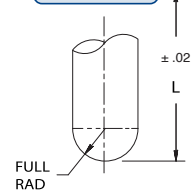

PRODUCT ALTERATIONS

Ball Lock Punches

BACK TAPER

S1 Round punches only

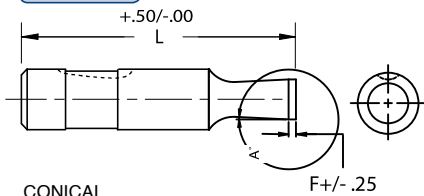

CONICAL

S2 Round punches only

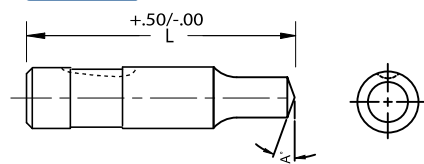

ROOF TOP

S3

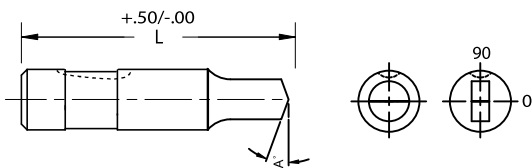

NAIL POINT

S4 Round punches only

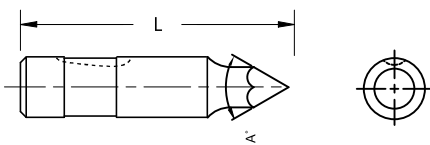

SHEAR

S5

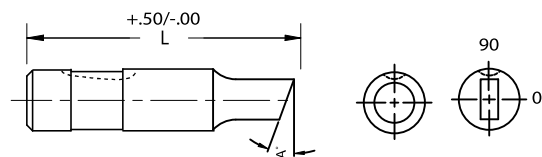

SHEAR WITH FLAT

S6

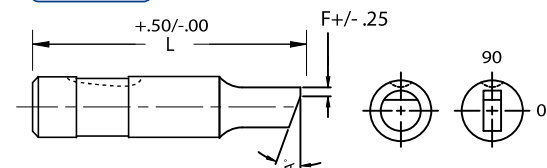

Shoulder Punches

BACK TAPER

S1 Round punches only

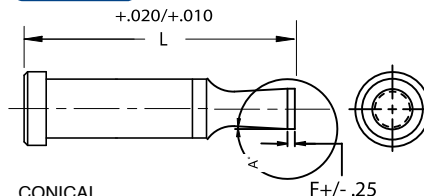

CONICAL

S2 Round punches only

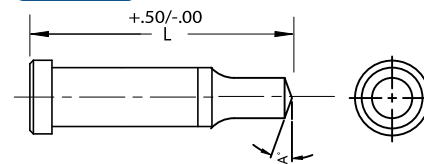

ROOF TOP

S3

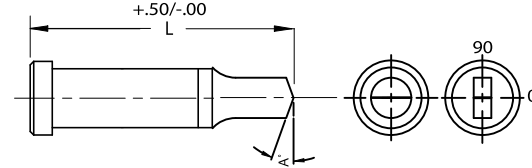

NAIL POINT

S4 Round punches only

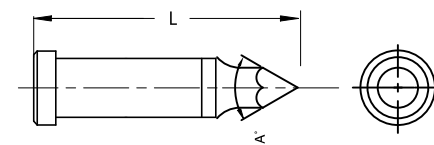

SHEAR

S5

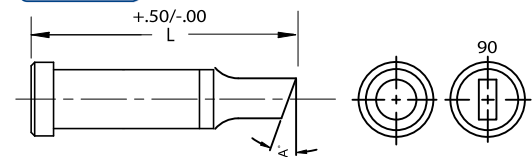

SHEAR WITH FLAT

S6

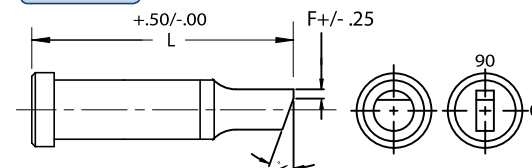

SHEAR ANGLES

Angle "A" and dimension "F" are user defined and must be specified with order.

VIEWES ARE SHOWN LOOKING THROUGH THE SHANK BUT DRAWN WITH SOLID LINES FOR CLARITY

Punch & Die Clearances

Clearance between punch and die is based upon type of material being stamped, material thickness, finish requirement of hole and anticipated tool life. It is expressed as a total percentage of material thickness being stamped. It is important to remember that the punch determines hole size and the die determines slug size. As a rule, optimal clearance provides flat, sharp and clean punching with minimum tool load. Insufficient clearance results in minimum burr and rollover, but tool life is shortened due to high tool loads. Excessive clearance results in deformation and larger rollover but increased tool life. Below are some general guidelines for different types of material being stamped. The values shown are recommended total die clearance for general purpose holes using non-ejector punches. By doubling the amount of clearance and using ejector punches, anticipated tool life will be greatly increased. Most of the punch wear is produced by stripping forces when the punch is being withdrawn. The increased clearance by using ejector punches helps keep tool wear to a minimum.

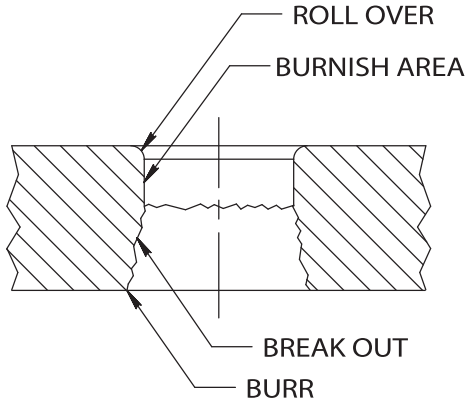

Suggested Die Clearance and Tooling Materials			
	Minimum Die Clearance Per Side	Recommended Punch Material	Recommended Button Material
Non-Alloyed Steel	10%	M2	M2 or A2
Steel < 250 Mpa	10%	M2	M2 or A2
Steel > 400 Mpa	12%	M2 or PM-M4	M2 or A2
High Strength Steels	15%	PM-M4	M2
Aluminum	13%	PM-M4	M2
Stainless Steels	12%	PM-M4	M2
Brass / Bronze / Copper	13%	M2 or PM-M4	M2 or A2
Plastics / Composites	1%	M2 or PM-M4	M2 or A2

Suggested Surface Treatment Applications

	Forming & Extruding					Piercing & Trimming			
	Draw/Flange	Extruding	Forging	Hot Forming	Coin/Emboss	Pierce & Trim	Hot Stamping	Fine Blanking	Shave/Lance
Non-alloyed Steel	TAN	TAN MWU* ACD	TAN MWU* ACD	TAN MWU* ACD	TCN TAN MTN	TAN ACE	ACE TAN TCN	TCN ACE ACA	TCN ACE
Steel < 250 Mpa	TIN TCN	ACE MWU* ACD MTN			TCN MTN	TIN TCN		TCN ACE	TIN TCN ACE
Steel < 400 Mpa	TCN ACE	ACE MWU*			TCN ACE	ACE MWU* ACA		TAN ACE	TAN TCN ACE
High Strength Steels	ACE TCN	ACE TCN TAN		ACE MWU* ACD	TCN ACE MWU*	ACE MWU* ACA	ACE TCN MWU* ACA	TAN ACE	TAN ACE
Aluminum	MAY	MAY	MAY		MAY TCN	MAY		MAY	MAY
Stainless Steel	TCN ACE MWU* ACD	TCN ACE MWU* ACD	TCN ACE MWU* ACD		TCN MWU* ACD	ACE TCN MWU* ACA MSP		ACE TCN	ACE TCN
Brass / Bronze / Copper	CRN ACD	CRN MWU* ACD	CRN MWU* ACD		CRN MWU* ACD	CRN ACE TAN		CRN ACE TAN	CRN ACE TAN
Exotic Alloys	ACO	ACO	ACO		ACO	ACO		ACO	ACO

* M-Wear Ultra includes Moeller's Enhanced Surface Finish (ESF) **Moeller's Enhanced Surface Finish (ESF) is recommended for all aluminum applications

TIN - Titanium Nitride (TiN)	ACD - Alcrona EVO Duplex	ACE - Alcrona EVO (AlCrN-based)	MAY - Mayura DLC	MTN - M-Tride
TCN - Titanium Carbonitride (TiCN)	ACA - Alcrona EVO Advanced	CRN - Chromium Nitride (CrN)	MWU - M-Wear Ultra	
TAN - Titanium Aluminum Nitride (TiAlN)	ACO - Alcronos	ESF - Enhanced Surface Finish	MSP - Moeller Special Process	

TiN – (Titanium Nitride)

Alteration Order Code: TIN • Add 3 days to Delivery

TiN is the least expensive and most commonly used PVD (physical vapor deposition) wear resistant coating offering:

- Improved wear resistance on cutting edges and wear surfaces
- Improved lubricity for a reduction of adhesive wear
- Suitable thermal stability for most cold work metalworking applications

Note: TiN should be reserved for light stamping operations with use of stamping lubricants, and is not compatible for use with stainless steel, nickel, or copper applications.

TiCN – (Titanium CarboNitride)

Alteration Order Code: TCN • Add 4 days to Delivery

TiCN has a broad range of applications, including piercing and forming of carbon and stainless steels, nickel and copper.

- High wear resistance on cutting edges and wear surfaces
- Excellent toughness for high pressure applications
- Provides improved lubricity over TiN
- High micro hardness of 3000HV

Note: TiCN is suitable for forming and piercing both ferritic and austenitic stainless steel, but will perform better when forming. TiCN is also suitable for nickel and copper applications.

TiAlN - (Titanium Aluminum Nitride)

Alteration Order Code: TAN • Add 3 days to Delivery

TiAlN provides excellent protection against wear on cutting edges in applications where surface heat is generated.

- Excellent protection against abrasive wear
- Can be used with minimum lubrication
- Ideal for high heat applications, and highly stressed components
- Excellent for medium strength steels
- Allows increased press stroke speed

Alcrona EVO™ - (Aluminum Chromium Nitride Titanium Based)

Alteration Order Code: ACE • Add 5 days to Delivery

Oerlikon Balzers Alcrona EVO is the next evolution of their Alcrona series of PVD coatings, and is improved over the vastly popular Alcrona Pro. Alcrona EVO provides excellent all-around performance, thermal stability, and low coefficient of friction, for the most piercing and forming applications, including high-strength steels.

- Recommended for piercing and forming high-strength steels
- Excellent for hot stamping applications and applications which introduce thermal shock
- Exceptionally low coefficient of friction
- Extraordinarily high wear resistance and thermal stability
- Excellent for applications with high mechanical loads

Oerlikon Balzers Alcrona EVO Advanced

Alteration Order Code: ACA • Add 10 days to Delivery

Oerlikon Balzers Alcrona EVO Advanced combines the benefits of Alcrona EVO with “Advanced” thin-layer nitride technology to provide increased tool life over Alcrona EVO for tough piercing applications. .

- Thin nitride layer provides excellent toughness for piercing application
- Exceptionally low coefficient of friction
- Extraordinarily high toughness, wear resistance, and thermal stability
- Allows increased press stroke speeds

Oerlikon Balzers Alcrona EVO Duplex

Alteration Order Code: ACD • *Add 5 days to Delivery*

Oerlikon Balzers Alcrona EVO Duplex combines the benefits of Alcrona EVO with “Duplex” deep-layer nitride technology to provide increased tool life over Alcrona EVO for tough forming applications.

- Deep nitride layer provides excellent toughness for forming application
- Exceptionally low coefficient of friction
- Extraordinarily high wear resistance and thermal stability

Oerlikon Balzers Alcronos - (Aluminum Chromium Nitride based)

Alteration Order Code: ACO • *Add 5 days to Delivery*

Oerlikon Balzers Alcronos is the ultimate solution for stamping high performance alloys, such as stainless steel, titanium, Inconel, CuNiSi, and more. Alcronos offers exceptional resistance to abrasion, and the ability to maintain extremely tight tolerances, which equates to high productivity gains, and consistent part quality.

- Superbly smooth coating with outstanding adhesion
- High precision coating thickness with excellent cutting edge stability
- High coating hardness and wear resistance

CrN - (Chromium Nitride)

Alteration Order Code: CRN • *Add 5 days to Delivery*

Chromium Nitride is an excellent substitute for applications where hard chrome is preferred, but is significantly harder, has better coating adhesion. Chromium Nitride is foodstuff-neutral.

- Superior substitute to hard chrome
- Very high coating adhesion and hardness
- Excellent for forming low strength steels and copper
- Resistant to corrosion and aggressive chemicals

Oerlikon Balzers Mayura - (ta-C based)

Alteration Order Code: MAY • *Add 5 days to Delivery*

Oerlikon Balzers Mayura’s brilliant rainbow color reveals its true value in the demanding stamping of aluminum, and other non-ferrous materials, such as copper, plastics, etc. Mayura is harder and smoother than other DLC coatings, including Hard Carbon, which minimizes material adhesion, and it is extremely thin, which keeps cutting edges sharp.

- The ultimate solution for piercing and forming aluminum, and other non-ferrous materials
- Extreme protection against abrasive wear and galling
- Smooth coating surface provides a low coefficient of friction
- Retains sharp cutting edges
- High thermal stability

M-WEAR ULTRA

Alteration Order Code: MWU • *Add 7 days to Delivery*

Moeller exclusive tooling solution combines multi-part surface treatments and advanced coating technology to meet the demands of today’s toughest piercing and forming applications.

- Tailored to both piercing and forming applications
- High wear resistance for increased tool life
- Resists fatigue due to increased toughness
- Superior finish reduces the coefficient of friction
- Proven to increase tool life up to five times in high strength and stainless applications

MSP - (Moeller Special Process with TiCN)

Alteration Order Code: MSP • *Add 5 days to Delivery*

Moeller Special Process (MSP) offers the ultimate in cutting edge longevity and resistance to galling, while providing the benefits of TiCN coating.

- Superior Surface finish provides increased lubricity and resistance to galling
- Treatment to cutting edge increases cutting edge longevity



EXCEEDING INDUSTRY STANDARDS FOR OVER 60 YEARS

IMPROVE TOOL LIFE AND REDUCE DOWN TIME

As the art of metalforming continues to evolve, today's industry faces increasingly difficult challenges in processing high-strength and complex lightweight materials. Moeller's tooling for Advanced Stamping Applications provides solutions, which allow our customers to exceed the increased demands of modern materials.

PM-M4 vs M2 Punches

It is no longer just a question of TOUGHNESS vs. WEAR. Want to improve tool life and reduce downtime while stamping modern materials, such as high strength, martensitic steel, and aluminum? You need the optimum combination of toughness, wear resistance, and superior compressive strength. Moeller's new **Advanced Tooling Solutions** now offer a complete line of standard **PM-M4** punches. **PM-M4** provides an outstanding balance of toughness, wear resistance, and tensile strength, and will perform in the most demanding applications.

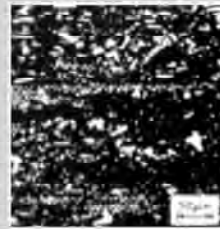
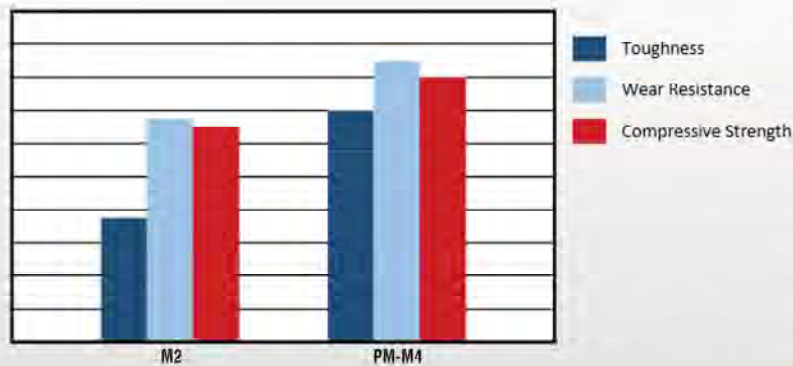

Standard (Non-PM) tool steel cross section. Large, non-uniform, disbursement of carbides allow cracking, chipping and premature wear.

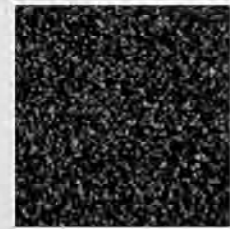

PM-M4 microstructure is uniform with fine disbursement of carbides providing greatly improved performance.

M2 vs A2 Punches

Stamping modern materials does not only require superior punch performance. The mating die buttons are also under increased demand. Moeller's **Advanced Tooling** M2 die buttons offer greatly increased wear resistance over A2 die buttons, and are the solution to many die problems associated with premature wear and edge breakdown.

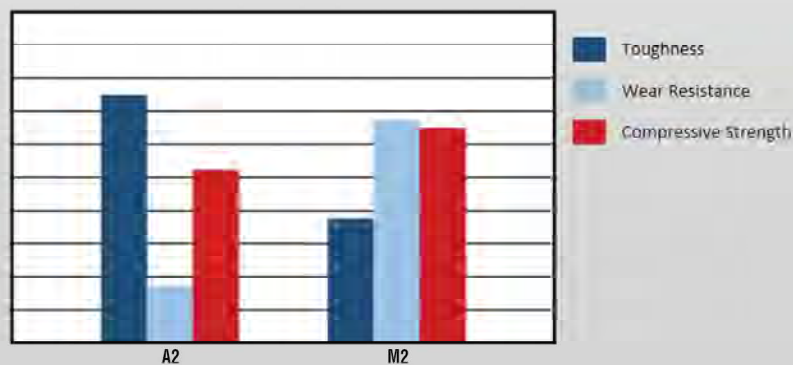

Contact a Moeller representative today to learn about our wide array of advanced solutions for your advanced application, including specialized performance coatings, unique punch configurations for unparalleled strength, and exclusive retainer geometry for improved punch retention.



Your Global Partner for Standard and Special Tooling Components



Powered by CADENAS
www.MoellerMCAD.com



STANDARD CATALOG ITEMS: PUNCHES • DIE BUTTONS • RETAINERS • STRIPPERS • DIE SPRINGS
CUSTOM MADE SPECIAL DETAILS: SPECIAL SHAPED PIERCING COMPONENTS • COMPLEX TRIMMING, FORMING
COINING AND BENDING TOOLS • PILOTS, GUIDING MEMBERS, LOCATING AND TRANSFERRING COMPONENTS

WEBSITE



MOELLER PRECISION TOOL - CORPORATE HEADQUARTERS
30893 CENTURY DRIVE • WIXOM, MICHIGAN 48393 U.S.A.
PH: 248.668.1166 • FX: 248.668.1004 • TOLL FREE 800.521.7613
E-Quote: quote@moellerpunch.com • www.moellerprecisiontool.com



MOELLER PRECISION TOOL - SOUTH
3048 OWEN DRIVE • ANTIOCH, TENNESSEE 37013 U.S.A.
PH: 615.371.0992 • FX: 615.371.9190 • TOLL FREE 800.227.7019
quote@moellersouth.com



MOELLER PRECISION TOOL DE MEXICO
CIRCUITO EL MARQUES SUR #43 • PARQUE INDUSTRIAL EL MARQUES
EL MARQUES, QUERETARO C.P. 76246 • PH: 442.253.12.00 • FX: 442.253.12.01
cotiza@moellerdemexico.com • www.moellerdemexico.com



MOELLER PRECISION TOOL CANADA ULC
225 BOIDA AVENUE • AYR, ONTARIO N0B 1E0
PH: 519.623.1144 • FX: 519.623.1004 • TOLL FREE 888.793.1303
quote@moellercanada.com • www.moellercanada.com



MOELLER PRECISION TOOL EUROPE SRL
VIA DON MINZONI 26 • 20056 TREZZO SULL'ADDA (MI) ITALY
PH: +39 (0)2 90937311 • quote@moellerpunch.eu



AW PRECISION LTD - A SUBSIDIARY OF MPT
64-66 SOMERS ROAD • RUGBY CV22 7DH • UNITED KINGDOM
PH: +44 (0)1788 542271 • sales@awprecision.co.uk • www.awprecision.co.uk